

Invacare® Storm®⁴ Series

Storm⁴, Storm⁴ X-plore, Storm⁴ True Track® Plus

en **Power Wheelchair
User Manual**

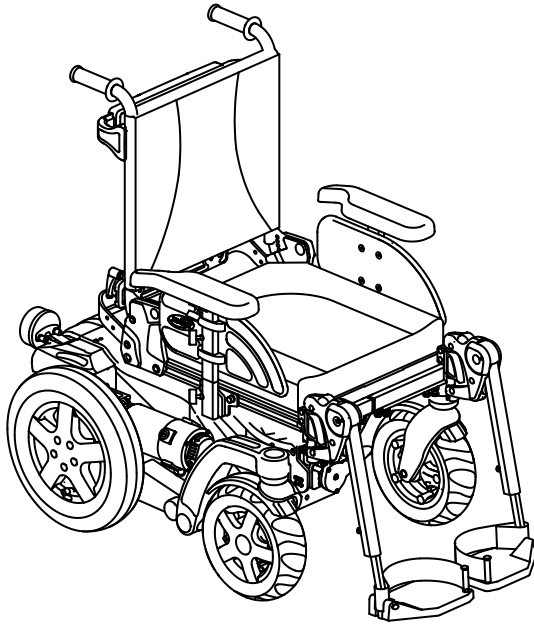

This manual **MUST** be given to the user of the product.
BEFORE using this product, read this manual and save for future reference.



Yes, you can.®

© 2017 Invacare Corporation

All rights reserved. Reproduction, duplication or modification in whole or in part is prohibited without prior written permission from Invacare. Trademarks are identified by ™ and ®. All trademarks are owned by or licensed to Invacare Corporation or its subsidiaries unless otherwise noted.

Contents

1 General	7
1.1 Introduction	7
1.2 Symbols in this manual	7
1.3 Type classification	8
1.4 Intended use	8
1.5 Regulations	8
1.6 Indications	8
1.7 Usability	8
1.8 Warranty	9
1.9 Service life	9
2 Safety	10
2.1 General safety notes	10
2.2 Safety information on the electrical system	12
2.3 Safety information on electromagnetic interference	14
2.4 Safety information on driving and freewheel mode	15
2.5 Safety information with regard to care and maintenance	18
2.6 Safety information regarding changes and modifications to the mobility device	19
2.7 Safety information on wheelchairs with a lifter	21
2.8 Safety information on wheelchairs with Recaro seats and AJ Optimist seats	22
2.9 The position of the labels on the product	23
3 Components	26
3.1 Main parts of the wheelchair	26
3.2 Remotes	26
3.3 The Lifter	26
4 Accessories	28
4.1 Posture belts	28
4.1.1 Types of posture belts	28
4.1.2 Adjusting the posture belt correctly	28
4.2 Using the cane holder	29

4.3 Using the KLiCKfix adapter	29
4.4 Adjusting or removing the luggage carrier	30
5 Setup	31
5.1 General setup information	31
5.2 Adjustment possibility for remote	32
5.2.1 Adjusting the remote for the length of the user's arm	33
5.2.2 Adjusting the height of the remote (only for swing-away remote supports)	33
5.2.3 Adjusting remote width	33
5.2.4 Swivelling the remote to the side	33
5.3 Adjustment options for standard armrests	34
5.3.1 Changing the arm support position	34
5.3.2 Setting height of armrests	34
5.3.3 Adjusting width of armrests	34
5.4 Adjustment options for parallel sliding armrests	35
5.4.1 Setting the height of the parallel sliding armrests	35
5.4.2 Adjusting angle of armpad on parallel sliding armrests	35
5.4.3 Adjusting the width of the parallel sliding armrests	36
5.4.4 Adjusting the mobility of the parallel sliding armrests	37
5.4.5 Adjusting the arm support positions for the parallel sliding armrests	37
5.5 Adjustment Possibilities for Nucleus Midline Holder	39
5.5.1 Adjusting Depth of Midline Holder	39
5.5.2 Adjusting Height of Nucleus Midline Holder	39
5.5.3 Adjusting Joystick/Display Position on Nucleus Midline Holder	39
5.6 Adjustment Possibilities for Chin Control	40
5.6.1 Adjusting Extremity Control Joystick	40
5.6.2 Adjusting Egg Switch	41
5.7 Adjusting Swing-Away Mechanism	42
5.8 Adjustment options for the Modulite seat unit	42
5.8.1 Adjusting the height of the armrests	42

5.8.2	Adjusting the width of the armrests	43	5.12.2	Adjusting the height	57
5.8.3	Adjusting the position of the armrest in depth	43	5.12.3	Adjusting the depth	57
5.8.4	Adjusting the height (flip-up armrest)	44	5.13	Adjusting and removing the tray	58
5.8.5	Adjusting the height (following armrest)	44	5.13.1	Laterally adjusting the tray	58
5.8.6	Changing the resistance (flip-up/following armrest)	44	5.13.2	Adjusting the depth of the tray / removing the tray	58
5.8.7	Adjusting the arm pad angle (flip-up/following armrest)	45	5.13.3	Swinging the tray away to the side	58
5.8.8	Adjusting the position of the arm pad of the flip-up armrest	45	5.14	Seat support	59
5.8.9	The hip support	46	5.14.1	Adjusting seat width	59
5.8.10	Adjusting the seat width	49	5.14.2	Adjusting the seat depth	59
5.8.11	Adjusting the seat depth	49	5.14.3	Adjusting the seat depth without replacing the seat support plate	61
5.9	Adjusting the seat angle	50	5.14.4	Adjusting the seat depth with replacing the seat support plate	62
5.9.1	Electrical	50	5.15	Backrest unit with ergonomic length compensation (Easy-Adapt)	63
5.9.2	Manually using spindle	50	5.15.1	Adjusting the width	63
5.10	Adjusting the backrest	51	5.16	Adjusting the suspension and the shock absorbance	63
5.10.1	Electrical	51	5.16.1	Adjusting the suspension (Storm ⁴ X-plore only)	64
5.10.2	Adjusting the backrest (standard seat) — manually with handscrews	51	5.16.2	Disabling the suspension and shock absorbance	64
5.10.3	Adjusting the back seat angle on the Easy-Adapt seating system	51	5.16.3	Adjusting the shock absorbance	64
5.10.4	Adjusting the height of the backrest (Modulite seat unit)	51	5.17	Center-mounted legrests — Electric legrest	65
5.10.5	Adjusting the width of the backrest (Modulite seat unit)	52	5.17.1	Lowering the electric legrest completely to assist getting out of the wheelchair	66
5.10.6	Adjusting the backrest angle (Modulite seat unit)	53	5.18	Center-mounted legrests — Adjustable legrest	67
5.10.7	Adjusting the adaptable backrest padding	54	5.18.1	Adjusting the angle	67
5.11	Adjusting the headrest	55	5.18.2	Adjusting the length of the legrest	67
5.11.1	Adjusting the position of the headrest or neckrest	55	5.18.3	Adjusting the calf pad to the calf width of the user	68
5.11.2	Adjusting the height of the headrest or neckrest	56	5.18.4	Adjusting the angle of the foot plate	68
5.11.3	Adjusting the cheek supports	56	5.19	Vari-F footrest	68
5.12	Adjusting the trunk supports	57	5.19.1	Swivelling the footrest/legrest outward and/or removing	68
5.12.1	Adjusting the width	57	5.19.2	Setting the angle	69
			5.19.3	Setting the end stop of the footrest	69
			5.19.4	Adjusting the length of the footrest	71

5.20	Vari-A legrests	71	7.5	Taking Obstacles	85
5.20.1	Swivelling the footrest/legrest outward and/or removing	71	7.5.1	Maximum obstacle height	85
5.20.2	Setting the angle	72	7.5.2	Safety information when taking obstacles	86
5.20.3	Setting the end stop of the legrest	73	7.5.3	The correct way to take obstacles	86
5.20.4	Adjusting the length of the legrest	75	7.6	Driving up and down gradients	87
5.20.5	Adjusting the depth of the calf pad	75	7.7	Using foldable antitippers	88
5.20.6	Adjusting the height of the calf pad	76	7.8	Use on public roads	88
5.20.7	Unlocking and swivelling the calf pad backward when alighting	76	7.9	Pushing the mobility device in freewheel mode	88
5.20.8	Adjusting the angle-adjustable foot plate	77	7.9.1	Disengaging motors (conventional motors)	89
5.20.9	Adjusting the angle- and depth-adjustable foot plate	77	7.9.2	Disengaging the motors (True Track® Plus motors)	90
5.21	Powered elevating legrests (ADE legrests)	78	7.10	Imperial to metric conversion chart	91
5.21.1	Swivelling the legrest outward and/or removing	78	8	Controls system	93
5.21.2	Setting the angle	78	8.1	Controls protection system	93
5.21.3	Adjusting the length of the legrest	78	8.2	Batteries	93
5.21.4	Adjusting the depth of the calf pad	79	8.2.1	General information on charging	93
5.21.5	Adjusting the height of the calf pad	79	8.2.2	General instructions on charging	93
5.21.6	Unlocking and swivelling the calf pad backward when alighting	79	8.2.3	How to charge the batteries	94
5.21.7	Adjusting the angle-adjustable foot plate	80	8.2.4	How to disconnect the mobility device after charging	95
5.21.8	Adjusting the angle- and depth-adjustable foot plate	80	8.2.5	Storage and Maintenance	95
5.22	Angle-adjustable footboard	81	8.2.6	Instructions on using the batteries	95
5.23	Adjusting the width of side-mounted legrests	81	8.2.7	Transporting batteries	96
6	Adjusting the mobility device to the user's seating posture	82	8.2.8	General instructions on handling the batteries	96
7	Usage	83	8.2.9	How to handle damaged batteries correctly	96
7.1	Driving	83	9	Transport	98
7.2	Before driving for the first time	83	9.1	Transport — General information	98
7.3	Parking and stationary	83	9.2	Transferring the mobility device to a vehicle	98
7.4	Getting in and out of the mobility device	83	9.3	Use of the mobility device as a seat in a vehicle	99
7.4.1	Removing the standard armrest in order to side transfer	83	9.3.1	How the mobility device is anchored in a vehicle	101
7.4.2	Information about getting in and out	84	9.3.2	How the user is secured within the mobility device	101
			9.4	Transporting the mobility device without occupant	103
			9.4.1	Opening the rear cover	103
			9.4.2	Making the batteries accessible	104
			9.4.3	Removing/Installing the batteries	105

10 Maintenance	.106
10.1 Maintenance introduction	.106
10.2 Cleaning the mobility device	.106
10.3 Inspection checks	.106
10.3.1 Before each use of the mobility device	.106
10.3.2 Weekly	.107
10.3.3 Monthly	.108
10.4 Wheels and tires	.108
10.5 Short-term storage	.109
10.6 Long-term storage	.109
10.7 Disconnect the power module	.110
11 After Use	.111
11.1 Reconditioning	.111
11.2 Disposal	.111
12 Technical data	.112
12.1 Technical specifications	.112
13 Service	.120
13.1 Inspections performed	.120

1 General

1.1 Introduction

Thank you for choosing an Invacare product.

This user manual contains important information about the handling of the product. In order to ensure safety when using the product, read the user manual carefully and follow the safety instructions.

Before reading this manual, make sure you have the latest version. You find the latest version as a pdf on the Invacare website (see back page of this manual). If you find that the font size in the print version of the user manual is difficult to read, you can download the pdf from the website. The pdf can then be scaled on screen to a font size that is more comfortable for you.

This mobility device has been constructed for a large circle of users with different requirements.

The decision whether the model is suitable for the user may only be taken by medical specialists with appropriate expertise.

Some maintenance and settings can be performed by the user or his/hers attendants. Certain adjustments do however require technical training and may only be carried out by your Invacare specialist provider. Refer to the Inspection checks chapter in *10 Maintenance, page 106* Damages and errors caused by nonobservance of the user manual or as a result of incorrect maintenance are excluded from all guarantees.

For more information about the product, for example product safety notices and product recalls, contact your local Invacare representative. For address and website see back page of this manual.

1.2 Symbols in this manual

In this manual, hazard statements are indicated by symbols. The symbols are accompanied by a signal word that indicates the severity of the risk.



WARNING

Indicates a hazardous situation that could result in serious injury or death if it is not avoided.



CAUTION

Indicates a hazardous situation that could result in minor or slight injury if it is not avoided.



IMPORTANT

Indicates a hazardous situation that could result in damage to property if it is not avoided.



Gives useful tips, recommendations and information for efficient, trouble-free use.



This product complies with Directive 93/42/EEC concerning medical devices. The launch date of this product is stated in the CE declaration of conformity.



This symbol identifies a list of various tools, components and items which you will need in order to carry out certain work.

1.3 Type classification

This vehicle has been classified according to EN 12184 as a **class B mobility product** (for indoor and outdoor areas). It is therefore compact and agile enough for indoor areas, but also able to overcome many obstacles in outdoor areas.

1.4 Intended use

This mobility device was designed for persons whose ability to walk is impaired, but who are still in terms of their eyesight and physically and mentally able to operate an electric mobility device.

1.5 Regulations

The vehicle was successfully tested according to German and international standards as to its safety. It satisfies the requirements according to RoHS 2011/65/EU, REACH 1907/2006/EC and DIN EN 12184 including EN 1021-2 and ISO 7176–14. It was also tested successfully according to EN 60529 IPX4 as to its resistance to spray water, and is therefore well suited for weather conditions such as typical European weather conditions. When equipped with an appropriate lighting system, the vehicle is suitable for use on public roads.

1.6 Indications

The use of this power wheelchair is recommended for the following indications:

- The inability or a greatly restricted ability to walk within the scope of the basic requirement to be able to move within one's own four walls.

- The need to leave the dwelling place in order to get some fresh air during a short walk or to reach those places generally to be found at close distance to the dwelling and where everyday business is carried out.

Provision of power wheelchairs for interior and exterior areas is advisable if the use of hand-operated wheelchairs is no longer possible on account of the disability, yet proper operation of an electromotive drive unit is still practicable.

Contraindications

There are no contraindications known.

1.7 Usability

Only use a mobility device when it is in perfect working order. Otherwise, you might put yourself and others at risk.

The following list does not claim to be exhaustive. It is only intended to show some of the situations that could affect the usability of your mobility device.

In certain situations, you should immediately stop using your mobility device. Other situations allow you to use the mobility device to get to your provider.

You should immediately stop using your mobility device if its usability is restricted due to:

- brake failure

You should immediately contact an authorized Invacare provider if the usability of your mobility device is restricted due to:

- the lighting system (if fitted) failing or being defective
- reflectors falling off
- worn thread or insufficient tire pressure

- damage to the armrests (e.g. torn armrest padding)
- damage to the legrest hangers (e.g. missing or torn heel straps)
- damage to the postural belt
- damage to the joystick (joystick cannot be moved into the neutral position)
- cables that are damaged, kinked, pinched or have come loose from the fixation
- the mobility device drifting when braking
- the mobility device pulling to one side when moving
- unusual sounds developing or occurring

Or if you have the feeling that something is wrong with your mobility device.

1.8 Warranty

The terms and conditions of the warranty are part of the general terms and conditions particular to the individual countries in which this product is sold.

1.9 Service life

We estimate a service life of five years for this product, provided it is used in strict accordance with the intended use as set out in this document and all maintenance and service requirements are met. The estimated service life can be exceeded if the product is carefully used and properly maintained, and provided technical and scientific advances do not result in technical limitations. The service life can also be considerably reduced by extreme or incorrect usage. The fact that we estimate a service life for this product does not constitute an additional warranty.

2 Safety

2.1 General safety notes

**DANGER!****Risk of Death, Serious Injury, or Damage**

Lighted cigarettes dropped onto an upholstered seating system can cause a fire resulting in death, serious injury, or damage. Mobility device occupants are at particular risk of death or serious injury from these fires and resulting fumes because they may not have the ability to move away from the mobility device.

- DO NOT smoke while using this mobility device.

**WARNING!****Risk of injury if mobility device is used in any other way than the purpose described in this manual**

- Only ever use the mobility device in accordance with the instructions in this user manual.
- Pay strict attention to the safety information.

**WARNING!****Risk of injury if the mobility device is driven when ability to operate a vehicle is impaired by medication or alcohol**

- Never drive the mobility device under the influence of medication or alcohol. If necessary, the mobility device must be operated by an attendant who is physically and mentally able.

**WARNING!****Risk of damage or injury if mobility device is accidentally set into motion**

- Switch the mobility device off before you get in, get out or handle unwieldy objects.
- When the drive is disengaged, the brake inside the drive is deactivated. For this reason, pushing the mobility device by an attendant is only recommended on flat surfaces, never on gradients. Never leave your mobility device on a gradient with its motors disengaged. Always re-engage the motors immediately after pushing the mobility device (refer to Pushing the mobility device in freewheel mode).

**WARNING!****Risk of injury if the mobility device is switched off while driving, for example by pressing the On/Off Button or disconnecting a cable, due to it coming to an abrupt, sharp stop**

- If you have to brake in an emergency, simply release the joystick which will bring you to a halt (refer to the remote user manual for more information).

**WARNING!****Risk of injury when transferring mobility device to a vehicle for transport with the occupant seated in it**

- It is always better to transfer the mobility device to a vehicle without the occupant seated in it.
- If the mobility device needs to be loaded up a ramp together with its driver, ensure that the ramp does not exceed the rated slope (refer to *12 Technical data, page 112*).
- If the mobility device does need to be loaded using a ramp which exceeds the rated slope (refer to *12 Technical data, page 112*), then you must use a winch. An attendant can safely monitor and assist the loading process.
- As an alternative you can use a platform lift. Ensure that the total weight of the mobility device including the user does not exceed the maximum permissible weight for the platform lift or winch if you are using.

**WARNING!****Risk of falling out of the mobility device**

- Do not slide forward on the seat, do not lean forward between your knees, do not lean backwards out over the top of the backrest, for example to reach an object.
- If a posture belt is installed, it should be correctly adjusted and used each time you use the mobility device.
- When transferring to a different seat, position the mobility device as close as possible to the new seat.

**WARNING!****Risk of Serious Injury or Damage**

- Storing or using the mobility device near open flame or combustible products can result in serious injury or damage.
- Avoid storing or using the mobility device near open flame or combustible products.

**CAUTION!****Risk of injury if maximum permissible load is exceeded**

- Do not exceed the maximum permissible load (refer to *12 Technical data, page 112*).
- The mobility device is only designed for use by a single occupant whose maximum weight does not exceed the maximum permissible load of the device. Never use the mobility device to transport more than one person.



CAUTION!

Risk of injury due to wrong lifting or dropping of heavy components

- When maintaining, servicing or lifting any part of your mobility device, take into account the weight of the individual components especially the batteries. Be sure at all times to adopt the correct lifting posture and ask for assistance if necessary.



CAUTION!

Risk of injury by moving parts

- Make sure that no injury is incurred by moving parts of the mobility device, like wheels or one of the lifter modules (if fitted), especially when children are around.



CAUTION!

Risk of injury from hot surfaces

- Do not leave the mobility device in direct sunlight for prolonged periods. Metal parts and surfaces such as the seat and armrests can become very hot.



CAUTION!

Risk of fire or breaking down due to electric devices being connected

- Do not connect any electric devices to your mobility device that are not expressly certified by Invacare for this purpose. Have all electrical installations done by your authorized Invacare provider.

2.2 Safety information on the electrical system



WARNING!

Risk of death, serious injury or damage

- Misuse of the mobility device may cause the mobility device to start smoking, sparking, or burning. Death, serious injury, or damage may occur due to fire.
- DO NOT use the mobility device other than its intended purpose.
 - If the mobility device starts smoking, sparking, or burning, discontinue using the mobility device and seek service IMMEDIATELY.



WARNING!

Risk of fire

- Switched on lamps produce heat. If you cover the lamps with fabrics such as clothes, there is a risk that the fabric may catch fire.
- NEVER cover the light system with fabric.

**WARNING!****Risk of death, serious injury or damage when carrying along oxygen systems**

Textiles and other materials that normally would not burn are easily ignited and burn with great intensity in oxygen enriched air.

- Check the oxygen tubing daily, from the cylinder to the delivery site, for leaks and hold away from electrical sparks and any source of ignition.

**WARNING!****Risk of injury or damage due to electrical shorts**

Connector pins on cables connected to the power module can still be live even when the system is off.

- Cables with live pins should be connected, restrained or covered (with non-conductive materials) so that they are not exposed to human contact or materials that could cause electrical shorts.
- When cables with live pins have to be disconnected, for example, when removing the bus cable from the remote for safety reasons, make sure to restrain or cover the pins (with non-conductive materials).

**WARNING!****Risk of death, serious injury, or damage**

Corroded electrical components due to water or liquid exposure can result in death, serious injury, or damage.

- Minimize exposure of electrical components to water and/or liquids.
- Electrical components damaged by corrosion **MUST** be replaced immediately.
- Mobility devices that are frequently exposed to water/liquids may require replacement of electrical components more frequently.



WARNING!

Risk of death or serious injury

Failure to observe these warnings can cause an electrical short resulting in death, serious injury, or damage to the electrical system.

- The POSITIVE (+) RED battery cable MUST connect to the POSITIVE (+) battery terminal(s)/post(s). The NEGATIVE (-) BLACK battery cable MUST connect to the NEGATIVE (-) battery terminal(s)/post(s).
- NEVER allow any of your tools and/or battery cable(s) to contact BOTH battery post(s) at the same time. An electrical short may occur and serious injury or damage may occur.
- Install protective caps on positive and negative battery terminals.
- Replace cable(s) immediately if cable(s) insulation becomes damaged.
- DO NOT remove fuse or mounting hardware from POSITIVE (+) red battery cable mounting screw.



WARNING!

Risk of death or serious injury

Electric shock can cause death or serious injury

- To avoid electric shock, inspect plug and cord for cuts and/or frayed wires. Replace cut cords or frayed wires immediately.



Risk of damage to the mobility device

A failure in the electric system can lead to unusual behavior such as continuous light, no light, or noises from the magnetic brakes.

- If a failure exists, switch off the remote and switch it on again.
- If a failure still exists, then disconnect or remove the power source. Depending on the mobility device model, you can either remove the battery packs or disconnect the batteries from the power module. If in doubt which cable to disconnect, contact your provider.
- In any case, contact your provider.

2.3 Safety information on electromagnetic interference

This electric vehicle was successfully tested in accordance with International standards as to its compliance with Electromagnetic Interference (EMI) regulations. However, electromagnetic fields, such as those generated by radio and television transmitters, and cellular phones can influence the functions of electric vehicles. Also, the electronics used in our vehicles can generate a low level of electromagnetic interference, which however will remain within the tolerance permitted by law. For these reasons we ask you to please observe the following precautions:

**WARNING!****Risk of malfunction due to electromagnetic interference**

- Do not switch on or operate portable transceivers or communication devices (such as radio transceivers or cellular phones) when the vehicle is switched on.
- Avoid getting near strong radio and television transmitters.
- In case the vehicle should be set in motion unintentionally or the brakes are released, switch it off immediately.
- Adding electrical accessories and other components or modifying the vehicle in any way can make it susceptible to electromagnetic interference. Keep in mind that there is no sure way to determine the effect such modifications will have on the overall immunity of the electronic system.
- Report all occurrences of unintentional movement of the vehicle, or release of the electric brakes to the manufacturer.

2.4 Safety information on driving and freewheel mode

**DANGER!****Risk of death, serious injury, or damage**

- Malfunctioning joystick could cause unintended/erratic movement resulting in death, serious injury, or damage
- If unintended/erratic movement occurs, stop using the wheelchair immediately and contact a qualified technician.



WARNING!

Risk of injury if the mobility device tips over

- Inclines and declines can only be travelled up to the rated slope (refer to *12 Technical data, page 112*).
- Always return the backrest of your seat or the seat tilt to an upright position before ascending slopes. We recommend that you position the seat backrest and the seat tilt (if fitted) slightly to the rear before descending slopes.
- Only ever drive downhill at a maximum of 2/3 of the top speed. Avoid abrupt braking or accelerating on gradients.
- If at all possible, avoid driving on wet, slippery, icy, or oily surfaces (such as snow, gravel, ice etc.) where there is a risk of you losing control over the vehicle, especially on a gradient. This may include certain painted or otherwise treated wood surfaces. If driving on such a surface is inevitable, then always drive slowly and with the utmost caution.
- Never attempt to overcome an obstacle when on an uphill or downhill gradient.
- Never attempt to drive up or down a flight of steps with your mobility device.
- When overcoming obstacles, always observe the maximum obstacle height (refer to *12 Technical data, page 112* and information about overcoming obstacles in *7.5 Taking Obstacles, page 85*).
- Avoid shifting your center of gravity as well as abrupt joystick movements and changes of direction when the mobility device is in motion.



WARNING!

Risk of injury if the mobility device tips over (continued)

- Never use the mobility device to transport more than one person.
- Do not exceed the overall maximum permissible load or the maximum load per axle (refer to *12 Technical data, page 112*).
- Note that the mobility device will brake or accelerate if you change the driving mode whilst the mobility device is in motion.



WARNING!

Risk of serious injury or damage

- Improper positioning while leaning or bending could cause the wheelchair to tip forward resulting in serious injury or damage
- To assure stability and proper operation of your mobility device, you must at all times maintain proper balance. Your power wheelchair has been designed to remain upright and stable during normal daily activities as long as you DO NOT move beyond the center of gravity.
 - DO NOT lean forward out of the mobility device any further than the length of the armrests.
 - DO NOT attempt to reach objects if you have to move forward in the seat or pick them up from the floor by reaching down between your knees.

**WARNING!**

Risk of breaking down in adverse weather conditions, i.e. extreme cold, in an isolated area

- If you are a user with severely limited mobility, we advise that in the case of adverse weather conditions DO NOT attempt a journey without an accompanying attendant.

**WARNING!**

Risk of injury if your foot slides off the footrest and gets caught underneath the mobility device when it is in motion

- Make sure each time before you drive the mobility device that your feet are squarely and securely in place on the footplates, and that both legrests are properly locked into place.

**WARNING!**

Risk of serious injury or damage

Operating the mobility device with a ground clearance of less than 76 mm between the footplate and ground/floor may cause serious injury or property damage.

- ALWAYS maintain a minimum of 76 mm between the bottom of the footplate and ground/floor to ensure proper ground clearance while the mobility device is in motion. If necessary, adjust the footplate height to achieve proper ground clearance.
- After footplate height adjustment, if the mobility device dips forward and the footplates touch the ground while in motion, please contact your dealer for an inspection and avoid use of the mobility device if possible.

**WARNING!**

Risk of injury if you collide with an obstacle when driving through narrow passages such as doorways and entrances

- Drive through narrow passages in the lowest driving mode and with due caution.



WARNING!

Risk of injury

If your mobility device has been fitted with elevating legrests, there is a risk of personal injury and damage to the mobility device if you drive the mobility device with the legrests raised.

- To avoid unwanted displacement of the mobility device center of gravity to the front (especially when travelling downhill) and in order to avoid damage to the mobility device, elevating legrests must always be lowered during normal travelling.



WARNING!

Risk of tipping

Antitippers (stabilizers) are only effective on firm ground. They sink in on soft ground such as grass, snow or mud if the mobility device rests itself on them. They lose their effect and the mobility device can tip over.

- Only drive with extreme care on soft ground, especially during uphill and downhill journeys. In the process pay increased attention to the tip stability of the mobility device.



WARNING!

Risk of injury or damage

Operating the wheelchairs outdoors or in areas of poor lighting may cause injury or damage. Operating the wheelchair near motor vehicles may cause injury or damage.

- DO NOT operate on roads, streets or highways.
- Use caution when operating the wheelchair outdoors at night or in areas with poor lighting.
- ALWAYS be aware of motor vehicles when using the wheelchair.

2.5 Safety information with regard to care and maintenance



WARNING!

Risk of death, serious injury, or damage

Incorrect repair and/or servicing of this mobility device performed by users/caregivers or unqualified technicians can result in death, serious injury, or damage.

- DO NOT attempt to carry out maintenance work that is not described in this user manual. Such repair and/or service MUST be performed by a qualified technician. Contact a provider or Invacare technician.

**CAUTION!****Risk of accident and loss of warranty if maintenance is insufficient**

- For reasons of safety and in order to avoid accidents which result from unnoticed wear, it is important that this mobility device undergoes an inspection once every year under normal operating conditions (see inspection plan contained in service instructions).
- Under difficult operating conditions such as daily travel on steep slopes, or in the case of use in medical care cases with frequently changing mobility device users, it would be expedient to carry out intermediate checks on the brakes, accessories and running gear.
- If the mobility device is to be operated on public roads, the vehicle driver is responsible for ensuring that it is in an operationally reliable condition. Inadequate or neglected care and maintenance of the mobility device will result in a limitation of the manufacturer's liability.

2.6 Safety information regarding changes and modifications to the mobility device

**WARNING!****Risk of serious injury or damage**

Use of incorrect or improper replacement (service) parts may cause injury or damage

- Replacement parts **MUST** match original Invacare parts.
- Always provide the wheelchair serial number to assist in ordering the correct replacement parts.



CAUTION!

Risk of injuries and damage to mobility device due to unapproved components and accessory parts

Seating systems, additions and accessory parts which have not been approved by Invacare for use with this mobility device can affect the tipping stability and increase tipping hazards.

- Only ever use seating systems, additions and accessory parts which have been approved by Invacare for this mobility device.

Seating systems which are not approved by Invacare for use with this mobility device do not, under certain circumstances, comply with the valid standards and could increase the flammability and the risk of skin irritation.

- Only use seating systems that have been approved by Invacare for this mobility device.

Electrical and electronic components which have not been approved by Invacare for use with this mobility device can cause fire hazards and lead to electromagnetic damage.

- Only ever use electrical and electronic components which have been approved by Invacare for this mobility device.

Batteries which have not been approved by Invacare for use with this mobility device can cause chemical burns.

- Only ever use batteries which have been approved by Invacare for this mobility device.



CAUTION!

Risk of injuries, and damage to the mobility device, if unapproved backrests are used

A retrofitted backrest which is not approved by Invacare for use with this mobility device may overload the backrest tube and thus increase the risk of injuries and of damage to the mobility device.

- Please contact your Invacare specialist provider who will perform risk analyses, calculations, stability checks etc. to ensure that the backrest can be used safely.



CE marking of the mobility device

- The conformity assessment/CE marking was carried out in accordance with Directive 93/42 EEC and only applies to the complete product.
- The CE marking is invalidated if components or accessories are replaced or added that have not been approved for this product by Invacare.
- In this case, the company that adds or replaces the components or accessories is responsible for the conformity assessment/CE marking or for registering the mobility device as a special design and for the relevant documentation.



Important information about maintenance work tools

- Some maintenance work which is described in this manual and can be carried out by the user without problems require the correct tools for proper work. If you do not have the correct tool available we do not recommend that you try to carry out the relevant work. In this case, we urgently recommend that you contact an authorized specialist workshop.

2.7 Safety information on wheelchairs with a lifter



WARNING!

Risk of injury by moving parts

- Never let objects get caught in the space underneath a raised lifter.
- Make sure that neither you nor anyone else is injured by placing hands, feet or other body extremities under the raised seat.
- Should you not be able to view under the seat, for example, due to limited manoeuvrability, turn the wheelchair once on its own axle before you lower the seat. This will allow you to make sure that nobody is located in the danger zone.



CAUTION!

Risk of injury if the wheelchair tips over

- Never exceed the maximum permissible load (see chapter *12 Technical data, page 112*).
- Avoid dangerous driving situations when the lifter is in a raised position, such as trying to overcome obstacles like curbs or driving up or down steep gradients.
- Never lean out of the seat when the lifter is raised.
- Inspect the lifter module at least once a month to make sure the automatic speed reduction function, which reduces the speed of the wheelchair when the lifter is raised, is working properly (see chapter *The Lifter*). Notify your authorized provider immediately if it is not working properly.



CAUTION!

Risk of malfunction of the lifter module

- Inspect the lifter module at regular intervals to make sure there are no foreign objects or visible damage, and to make sure the electric plugs are firmly inserted into their sockets.



CAUTION!

Damage to wheelchair caused by one-sided loading on lifter pillar

- One-sided loading occurs if the seat is raised and/or tilted. Always return your seat backrest to the upright position and the seat tilting to the horizontal position before ascending slopes. Never subject the lifter pillar to continuous single-sided loading. The raising and tilting function of the seat only provides additional rest positions.



Important information regarding speed reduction with raised lifter

- If the lifter has been raised above a certain point, the drive electronics considerably reduces the speed of the wheelchair. If speed reduction has been activated, drive mode can only be used to carry out minor movements of the wheelchair and not for regular driving. To drive normally, lower the lifter until the speed reduction has been deactivated again. See chapter The Lifter for details.

2.8 Safety information on wheelchairs with Recaro seats and AJ Optimist seats



CAUTION!

Risk of injury if the wheelchair tips over

- The center of gravity of a Recaro seat or AJ Optimist seat is higher than that of other seats. These seats are also heavier than other seating systems. The backrest can be leaned back 90° and 60° respectively. For these reasons there is an increased risk of tipping over.
- Never lean the backrest backward more than 30° degrees, and never exceed 15° when driving the wheelchair.

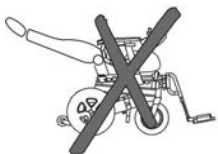

More than 30°
NEVER!!



15°-30°
Standstill!







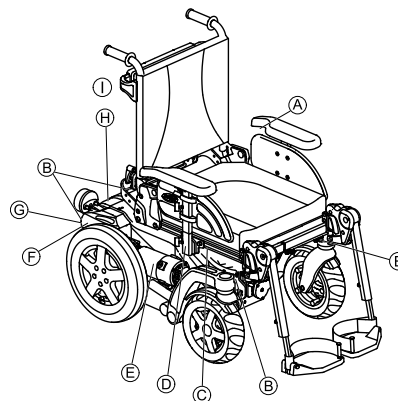

0°-15°
Driving

2.9 The position of the labels on the product











<p>Ⓐ</p>		<p>If the mobility device is fitted with a tray, it is imperative that it is removed and safely stowed when transporting the mobility device in a vehicle.</p>
<p>Ⓑ</p>	<p>Identification of the tie-down points at the front and back:</p> <p>ISO 7176-19</p>	<p>If the symbol appears on a bright yellow sticker, the tie-down point is suitable for fixation of the mobility device in a vehicle for use as a vehicle seat.</p>



C		<p>Warning regarding the use of the lifter</p> <p>For details see below</p>
D		<p>Indication of the maximum width to which the armrest can be set</p>
E		<p>Identification of the position of the coupling lever for driving and push operation (only the right side is visible in the picture).</p> <p>For details see below.</p>
F		<p>Identification label sticker on the chassis at the rear right.</p> <p>For details see below.</p>

G		<p>Warning not to use the cable loop as an tie-down point.</p>
H	 <p>ISO 7176-19</p>	<p>Warning that the mobility device may not be used as a vehicle seat.</p> <p>This mobility device does not satisfy the requirements of ISO 7176-19.</p>
I		<p>Indication of pinch points that could occur on the mobility device</p>

Explanation of symbols on labels

	<p>Do not lean out when the lifter is raised!</p>
	<p>Do not drive up or down slopes when the lifter is raised!</p>
	<p>Do not allow any body parts to get under a raised seat!</p>

	Never drive with two people!
	Never drive over uneven surfaces when the lifter is raised!
	Read the user manual. This symbol appears on different labels and positions.
	<p>This symbol indicates the “Drive” position of the coupling lever. In this position the motor is engaged and the motor brakes are operational. You can drive the mobility device.</p> <ul style="list-style-type: none"> Note that for driving purposes both motors must always be engaged.
	<p>This symbol indicates the “Push” position of the coupling lever. In this position the motor is disengaged and the motor brakes are not operational. The mobility device can be pushed by an attendant and the wheels turn freely.</p> <ul style="list-style-type: none"> Note that the remote must be switched off. Also note the information provided in section 7.9 <i>Pushing the mobility device in freewheel mode</i>, page 88.

	Date of manufacture
	This product complies with Directive 93/42/EEC concerning medical devices. The launch date of this product is stated in the CE declaration of conformity.
	<p>This product has been supplied from an environmentally aware manufacturer. This product may contain substances that could be harmful to the environment if disposed of in places (landfills) that are not appropriate according to legislation.</p> <ul style="list-style-type: none"> The 'crossed out wheellie bin' symbol is placed on this product to encourage you to recycle wherever possible. Please be environmentally responsible and recycle this product through your recycling facility at its end of life.

3 Components

3.1 Main parts of the wheelchair



- 1 Headrest
- 2 Backrest
- 3 Armrest
- 4 Battery case (rear)
- 5 Drive wheel
- 6 Drive motor (with engaging lever)
- 7 Remote
- 8 Legrests
- 9 Caster wheel

- 10 Suspension, rear (both not visible in illustration, adjustable for Storm4 X-plore only)
- 11 Suspension, center (Storm4 X-plore only)

3.2 Remotes

Your mobility device may be fitted with one of several different remotes. For information on the different functions and how to operate a particular remote, refer to its corresponding user manual (enclosed).

3.3 The Lifter

The electric lifter is operated from the remote. Refer to the remote manual for more information.



Information regarding operation of the lifter at temperatures of less than 0 °C

- Invacare mobility devices are fitted with safety mechanisms that prevent capacity overload of the electronic components. At operating temperatures below freezing point this can, in particular, lead to the lifter actuator being shut down after approx. 1 second operating time.
- The lifter can be raised or lowered gradually by repeatedly operating the joystick. In many cases this generates sufficient heat for the actuator to operate as normal.

**CAUTION!****Risk of tipping, if the speed limiter sensors fail when the lifter is raised**

- If you find that the speed reduction function is not working when the lifter is raised, do not drive with the lifter raised and immediately contact an authorized Invacare provider.

**Limit switch**

- If the lifter is raised above a certain point you can adjust the seat and backrest angles only at a combined total of max. 15° to ensure a safe driving behavior. The set-up allows full tilt and backrest adjustment when the lifter is down. In case the tilt and backrest angle exceed 15° (for example, 10° tilt and 10° backrest recliner), the lifter function is disabled.

4 Accessories

4.1 Posture belts

A posture belt is an option which can either be fixed to the mobility device ex-works or can be retrofitted by your specialist provider. If your mobility device is fitted with a posture belt, your specialist provider will have informed you about fitting and usage.

The posture belt is used to help the mobility device user keep an optimum seating position. Correct use of the belt assists the user in sitting securely, comfortably and well-positioned in the mobility device, especially for such users who do not have such a good sense of balance while sitting.



We recommend using the posture belt whenever the mobility device is used.

4.1.1 Types of posture belts

Your mobility device can be fitted with the following posture belt types ex-works. If your mobility device has been fitted with a different belt to those listed below, please ensure that you have received the manufacturer's documentation with regard to correct fitting and use.

Belt with metal buckle, adjustable one side



Belt can only be adjusted on one side which can result in the buckle not sitting centrally.

Belt with metal buckle, adjustable both sides



Belt can be adjusted on both sides. This means that the buckle can be centrally positioned.

4.1.2 Adjusting the posture belt correctly



The belt should be tight enough to ensure that you are sitting comfortably and that your body is in the correct sitting position.

1. Ensure that you are sitting correctly, which means that you are sitting right at the back of the seat, your pelvis is positioned erect and as symmetrically as possible, not to the front, to the side or at one edge of the seat.
2. Position the posture belt so that your hipbones can be easily felt above the belt.
3. Adjust the belt length using one of the adjustment aids described above. The belt should be adjusted so that you can fit a flat hand between the belt and your body.

4. The buckle should be positioned as centrally as possible. In doing so, carry out adjustments on both sides as much as possible.
5. Check your belt every week to ensure that it is still in good working condition, to ensure it has no damage or wear, and that it is fixed properly to the mobility device. If the belt is only fastened with a bolted connection, ensure that the connection has not loosened or come undone. You can find more information about maintenance work on belts in the service manual, which is available from Invacare.

4.2 Using the cane holder

If your mobility device is fitted with a cane holder, it can be used for the safe transport of a walking cane, underarm or forearm crutches. The cane holder consists of a plastic container (bottom) and a hook-and-loop fastener (top).



CAUTION! Risk of injury

A walking cane or crutches that are not secured during transport (on the user's lap, for example) can cause injury to the user or other persons.

- During transport, walking canes or crutches should always be secured using a cane holder.

1. Open the upper hook-and-loop fastener.
2. Place the lower end of the walking cane or the crutches in the container at the bottom.
3. The walking cane or the crutches can be secured at the upper end using the hook-and-loop fastener.

4.3 Using the KLICKfix adapter

Your mobility device can be fitted with the mini-adapter from the Rixen + Kaul KLICKfix system. To this you can attach various accessories such as the cellphone case supplied by Invacare, which you can use to transport your cellphone, sports glasses etc.



Risk posed by unsecured accessories

Accessories can fall off and get lost if they are not properly secured.

- Check that the accessory is correctly locked in and seated securely every time you use the mobility device.



Risk of breakage due to excessive load

The KLICKfix adapter can break if too great a load is applied.

- The maximum permitted load on the KLICKfix adapter is 1 kg.

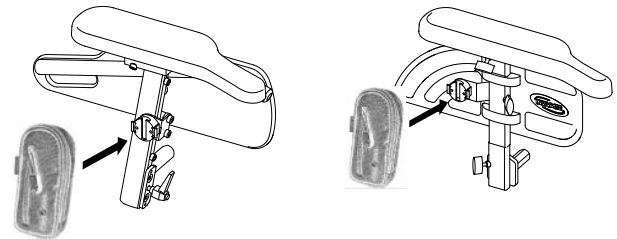

Securing the accessory:

1. Push the accessory into the KLICKfix adapter.
The accessory locks in securely.

Removing the accessory:

1. Press the red button and remove the accessory.

The adapter can turn in 90° steps, allowing you to attach an accessory from any of four different directions. Please refer to the installation instructions which are available from your Invacare provider or directly from Invacare.

More information on the KLICKfix system is available at <http://www.klickfix.com>.

4.4 Adjusting or removing the luggage carrier

- ! **Risk of damage as a result of collisions**
Parts of the mobility device may be damaged if the luggage carrier collides with the seat during seat angle or backrest adjustment.
 - Ensure that the luggage carrier is out of the range of both seat angle and backrest adjustment.

- ! **Risk of breakage due to excessive load**
The luggage carrier can break if too great a load is applied.
 - The maximum permitted load on the luggage carrier is 10 kg.

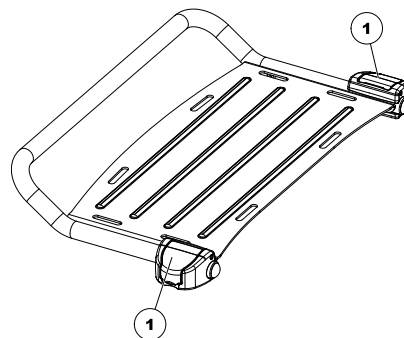

1. Open the clamp levers (1) of the luggage carrier bracket.
2. Slide the luggage carrier forward or backward or remove it.
3. Close the clamp levers of the luggage carrier bracket.

5 Setup

5.1 General setup information



WARNING!

Risk of death, serious injury, or damage

Continued use of the mobility device that is not set to the correct specifications may cause erratic behavior of the mobility device resulting in death, serious injury, or damage.

- Performance adjustments should only be made by professionals of the healthcare field or persons fully conversant with this process and the driver's capabilities.
- After the mobility device has been set-up/adjusted, check to make sure that the mobility device performs to the specifications entered during the set-up procedure. If the mobility device does not perform to specifications, IMMEDIATELY turn the mobility device Off and re-enter set-up specifications. Contact Invacare, if mobility device still does not perform to correct specifications.



WARNING!

Risk of death, serious injury, or damage

Attaching hardware that is loosely secured or missing could cause instability resulting in death, serious personal injury, or property damage.

- After ANY adjustments, repair or service and before use, make sure that all attaching hardware is present and tightened securely.



WARNING!

Risk of injury or damage

Incorrect set up of this mobility device performed by users/caregivers or unqualified technicians can result in injury or damage.

- DO NOT attempt to set up this mobility device. Initial set up of this mobility device MUST be performed by a qualified technician.
- Adjustment by the user is only recommended after they have been given appropriate guidance by the healthcare professional.
- DO NOT attempt to carry out the work if you do not have the listed tools available.





CAUTION!

Damage to mobility device and accident hazard

It is possible that collisions can occur between mobility device components due to various combinations of adjustment options and their individual settings

- The mobility device is fitted with an individual, multiply adjustable seating system including adjustable legrests, armrests, a headrest or other options. These adjustment options are described in the following chapters. They are used to adapt the seat to the physical requirements and the condition of the user. When adapting the seating system and the seat functions to the user, ensure that no mobility device components collide.

 Initial setup should always be done by a healthcare professional. Adjustment by the user is only recommended after they have been given appropriate guidance by the healthcare professional.

 Note that there may be sections in this user manual, which are not relevant to your product, since this manual applies to all existing modules (on the date of printing).

Electrical adjustment options

 Refer to the user manual for your remote for more information on operating electrical adjustment options

Recaro® seats and AJ Optimist seats

 For more information on a Recaro® seat or AJ Optimist seat, refer to the separate user manuals that come with the seats.

5.2 Adjustment possibility for remote

The following information is valid for all seating systems.



CAUTION!

Risk of the remote being pushed backwards during an accidental collision with an obstacle, such as a doorframe or table, and the joystick being jammed against the armpad if the position of the remote is adjusted and all screws are not completely tightened

This will cause the mobility device to drive forward uncontrollably and potentially injure the mobility device user and any person standing in the way.

- When adjusting the position of the remote, always make sure to tighten all screws securely.
- If this should accidentally happen, immediately switch the mobility device electronics OFF at the remote.



CAUTION!

Risk of injury

When leaning on the remote, for example, when transferring into or out of the wheelchair, the remote holder may break and the user may fall out of the chair.

- Never lean on the remote as a support for, for example, transfer.

5.2.1 Adjusting the remote for the length of the user's arm

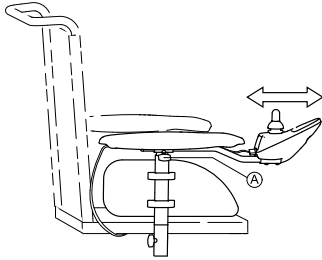

1. Loosen wing bolt (A).
2. Shift the remote forwards or backwards to the desired distance.
3. Retighten the bolt.

5.2.2 Adjusting the height of the remote (only for swing-away remote supports)



- 6 mm Allen key

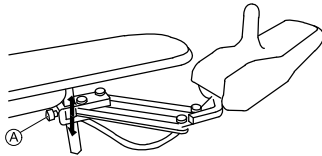

1. Loosen Allen screw (A).
2. Adjust remote to desired height.
3. Re-tighten Allen screw.

5.2.3 Adjusting remote width

The remote can be adjusted 20 mm widthwise.

1529686-S



- 3 mm Allen key

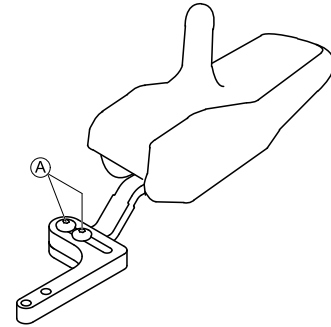

1. Loosen Allen screws (A).
2. Adjust remote to desired width.
3. Re-tighten Allen screws.

5.2.4 Swivelling the remote to the side

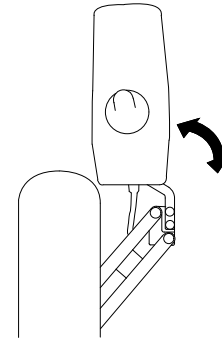

If your mobility device is fitted with a swing-away remote holder, then the remote can be moved away to the side, for example, to drive up close to a table.

5.3 Adjustment options for standard armrests

5.3.1 Changing the arm support position



Tools:

- 1 x Allen key 3 mm

The arm support has 12 possible positions.

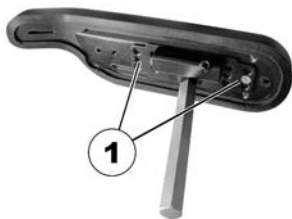

1. To change the position of the arm support, loosen the screw (1) and remove it.
2. The position of the arm support is adjusted by selecting a combination of screw holes in the arm support and the drill holes in the fixing plate.
3. Reposition the screws and tighten.

5.3.2 Setting height of armrests



- 3 mm Allen key

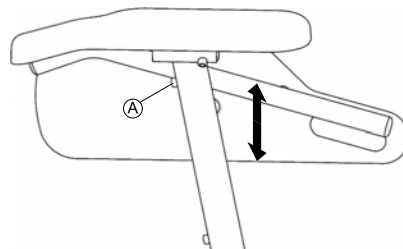

1. Loosen screw (A).
2. Adjust armrest to desired height.
3. Re-tighten screw.

5.3.3 Adjusting width of armrests



WARNING!

Serious risk of injury if one of the armrests falls out of its bracket because they have been adjusted to a width which exceeds the permissible value

- The width adjustment is fitted with red markings (A) and the word "STOP". The armrests must never be pulled out further than the point at which the word "STOP" is completely legible.
- Always tighten the fixing screws properly once adjustments have been completed.

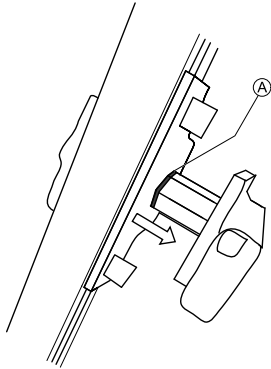

 Depending on the side, the screw is accessible from the front or the rear.



- 8 mm Allen key

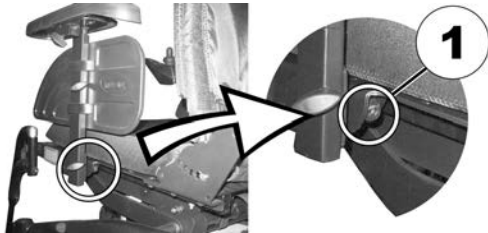

1. Loosen screw (1).
2. Adjust armrest to required position.
3. Re-tighten screw.
4. Repeat this procedure for the second armrest.

5.4 Adjustment options for parallel sliding armrests

5.4.1 Setting the height of the parallel sliding armrests

The height of the parallel sliding armrest is set using the armrest angle.

1.



Release the knob to adjust the armrest angle (1).

2.



Set the angle for the armrest.

3. Retighten the knob.

After adjusting the armrest height, the angle of the armpad needs to be adjusted. Refer to *5.4.2 Adjusting angle of armpad on parallel sliding armrests*, page 35.

5.4.2 Adjusting angle of armpad on parallel sliding armrests



- 5 mm Allen key

1.



Loosen screws (1).

2.



Set angle for armrest.

3. Re-tighten screws. Make sure that Nordlock washers used are re-inserted.

5.4.3 Adjusting the width of the parallel sliding armrests

The parallel sliding armrests can be adapted to the backrest in eight widths.



Tools:

- 4 mm Allen key

1.



Undo the bolts on both sides of the backrest cover (1). The photograph only shows the bolts on the left-hand side.

2. Remove the backrest cover (2).

3.

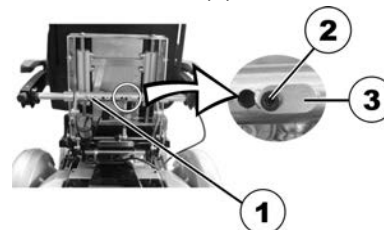

On the torque support, loosen the locating pin (3) bolt (2) with the Allen key.

4. Reduce the load on the armrest by raising it slightly and then remove the locating pin.

5.



Adjust the armrest width.

The possible positions for the armrest are predefined by the drill-holes in the torque support and the armrest axel.

6. Insert the locating pin.
7. Retighten the screw.
8. Repeat the procedure for the other armrest.
- 9.



Replace the backrest cover (2). When doing so, ensure that the recesses in the sides are located correctly.

10. Retighten the bolts on both sides of the backrest cover (1) again.

The photograph only shows the bolts on the left-hand side.

5.4.4 Adjusting the mobility of the parallel sliding armrests

The flexibility of the parallel sliding armrest can be adjusted to easier or stiffer.



Tools:

- 5 mm Allen key

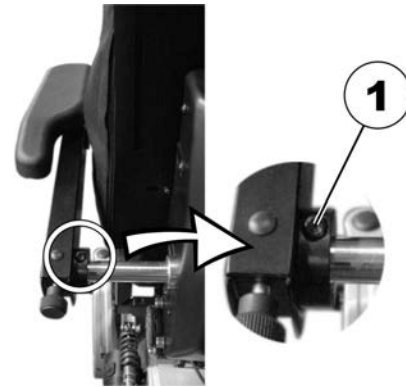

1. To make the armrest easier to move, release the bolt of the adjusting wrench (1) with the Allen key.
2. To make the armrest more difficult to move, tighten the bolt of the adjusting wrench (1) with the Allen key.

5.4.5 Adjusting the arm support positions for the parallel sliding armrests



Tools:

- 5 mm Allen key

1.



Put the armrest in the vertical position.

2. Release the interior bolts (1) with the Allen key.

3.

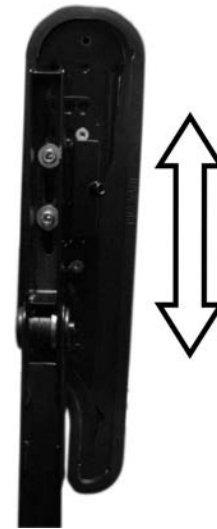

Position the armrest horizontally.

4. Re-tighten the bolts.
Make sure that the Nordlock washers used are re-inserted.

5.5 Adjustment Possibilities for Nucleus Midline Holder

5.5.1 Adjusting Depth of Midline Holder

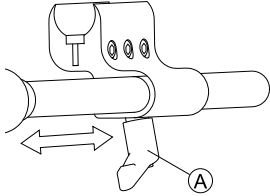

1. Loosen lever (A).
2. Shift midline holder to desired position.
3. Tighten lever.

5.5.2 Adjusting Height of Nucleus Midline Holder

You can adjust the height of the nucleus midline holder in two ways:

- Adjust it together with the armrest height. Refer to corresponding armrest chapters.
- Adjust the height of the nucleus midline holder only. Refer to section below.

-
-  • 3/16" (4.8 mm) Allen key
-

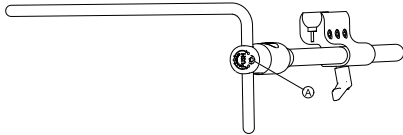

1. Loosen screw (A).
2. Adjust nucleus to desired height.
3. Tighten screw.

5.5.3 Adjusting Joystick/Display Position on Nucleus Midline Holder

DLX-REM500

-
-  • 3/16" (4.8 mm) Allen key
-

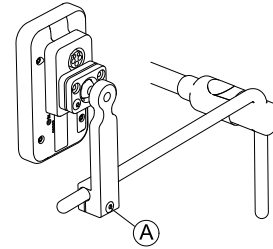

1. Loosen screw (A).
2. Position display on nucleus.
3. Tighten screw.

DLX-CR400 and DLX-CR400LF

-
-  • 5/32" (4 mm) Allen key
-

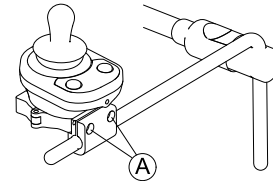

1. Loosen screws (A).
2. Position joystick on nucleus.
3. Tighten screws.

-
-  • 1/8 " (3 mm) Allen key
-

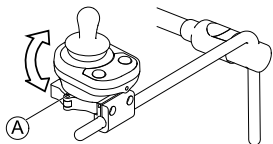

1. Loosen screw (A).
2. Open clamp and position joystick on nucleus.
3. Tighten screw.

ASL Components on Nucleus Tray

-
-  • 3/16" (4.8 mm) Allen key
-

The following graphic serves as an example.

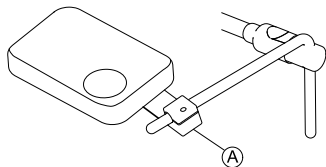

1. Loosen screw (A).
2. Position joystick on nucleus.
3. Tighten screw.

ASL Components on Nucleus Only

-
-  • 5/32" (4 mm) Allen key
-

The following graphic serves as an example.

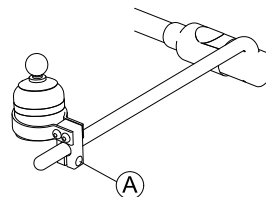

1. Loosen screw (A).
2. Position joystick on nucleus.
3. Tighten screw.

5.6 Adjustment Possibilities for Chin Control

5.6.1 Adjusting Extremity Control Joystick

Adjusting Position on Holder

-
-  • 5/32" (4 mm) Allen key
-

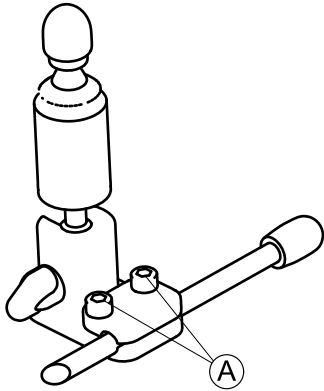

1. Loosen screws Ⓐ.
2. Position joystick on holder.
3. Tighten screws.

Adjusting Joystick Orientation

The joystick can be turned through 360 degrees. A slot on the side allows you to angle the joystick at 90 degrees.

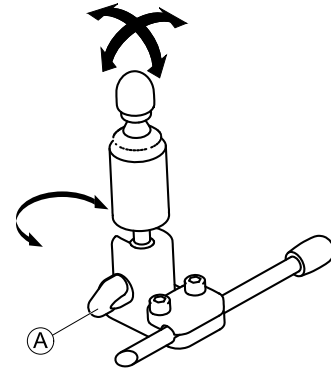

1. Loosen hand screw Ⓐ.
2. Turn underpart of joystick to position slot.
3. Adjust joystick orientation. If desired, lock joystick in 90 degree angle in slot.
4. Tighten hand screw.

Adjusting Depth and Height

Refer to *5.7 Adjusting Swing-Away Mechanism, page 42.*

5.6.2 Adjusting Egg Switch

Adjusting Switch Orientation

The egg switch can be turned through 360 degrees.



- 7/16" (11.2 mm) wrench

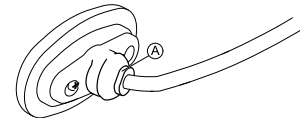

1. Loosen nut (A).
2. Adjust egg switch orientation.
3. Tighten nut.

Adjusting Depth and Height

Refer to 5.7 *Adjusting Swing-Away Mechanism*, page 42.

5.7 Adjusting Swing-Away Mechanism

The swing-away mechanism can be used for different options such as:

- PROTON wings of head array
- Extremity control joystick for chin control
- Egg switch



- 5/32" (4 mm) Allen key
-

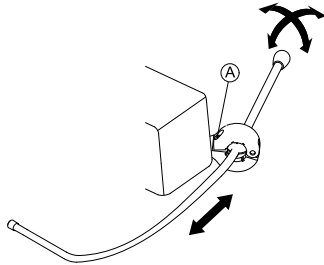

Adjusting Depth

1. Loosen screw (A).
2. Adjust rod to desired depth.
3. Tighten screw.

Adjusting Position

The swing-away mechanism can be turned through 360 degrees.

1. Loosen screw (A).
2. Adjust to desired position.
3. Tighten screw.

5.8 Adjustment options for the Modulite seat unit

5.8.1 Adjusting the height of the armrests

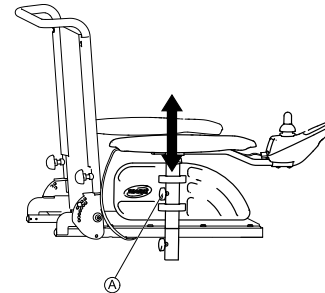

1. Loosen wing screw (A).
2. Adjust armrest to desired height.
3. Re-tighten wing screw.

5.8.2 Adjusting the width of the armrests



WARNING!

Serious injury hazard if one of the armrests falls out of its bracket because they have been adjusted to a width which exceeds the permissible value

- The width adjustment is fitted with red markings **A** and the word "STOP". The armrests must never be pulled out further than the point at which the word "STOP" is completely legible.
- Always tighten the fixing screws properly once adjustments have been completed.

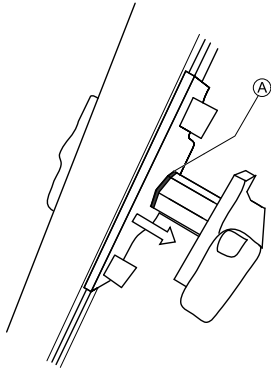

Depending on the side, the screw is accessible from the front or the rear.



- 8 mm Allen key

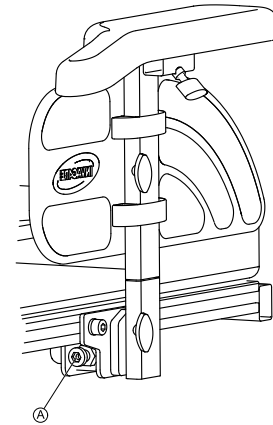

1. Loosen screw **A**.
2. Adjust armrest to required position.
3. Retighten the screw.
4. Repeat this procedure for the second armrest.

5.8.3 Adjusting the position of the armrest in depth



- 6 mm Allen key

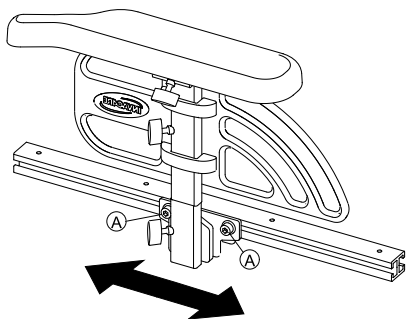

1. Loosen the screws **A** and move the armrest lengthwise.
2. Tighten the screws.

5.8.4 Adjusting the height (flip-up armrest)

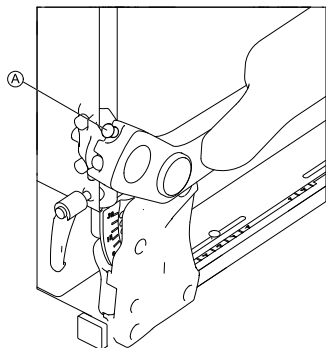

1. Loosen thumb screw **A**.
2. Adjust armrest to desired height.
3. Retighten thumb screw.

5.8.5 Adjusting the height (following armrest)



Tools:

- 5 mm Allen key
- 13 mm wrench

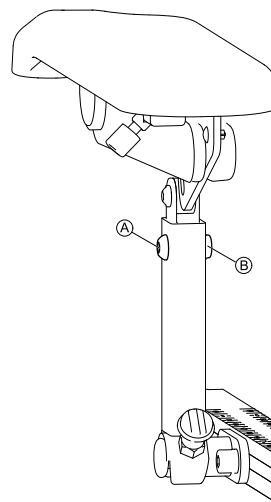

1. Loosen the screw **A** and nut **B** and remove them.
2. Adjust armrest to desired height.
3. Insert screw and nut and tighten.

5.8.6 Changing the resistance (flip-up/following armrest)

The movement of the flip-up and following armrests can be set to have greater or less resistance.



Tools:

- 5 mm Allen key

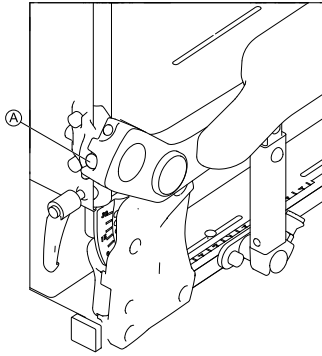

1. To make the armrest easier to move, release the screw Ⓐ with the Allen key.
2. To make the armrest more difficult to move, tighten the screw Ⓐ with the Allen key.

5.8.7 Adjusting the arm pad angle (flip-up/following armrest)



Tools:

- 5 mm Allen key

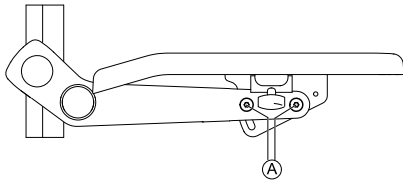

1. Loosen screws Ⓐ.



Do not remove them.

2. Adjust arm pad to desired angle.
3. Tighten screws.

5.8.8 Adjusting the position of the arm pad of the flip-up armrest



- 5 mm Allen key



1. Put the armrest in the vertical position.
2. Release the interior bolts (1) with the Allen key.

3.



Position the armrest horizontally.

4. Re-tighten the bolts.
Make sure that the Nordlock washers used are re-inserted.

5.8.9 The hip support

The hip support can be combined with the flip-up armrest only.

Removing hip support

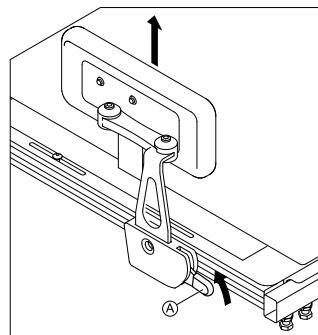

1. Pull lever Ⓐ upwards.
2. Remove hip support from holder.

Inserting hip support

1. Insert hip support in holder.
2. Push lever Ⓐ downwards.
Ensure that hip support locks with an audible click.

Adjusting position of hip support



Tools

- 5 mm Allen key

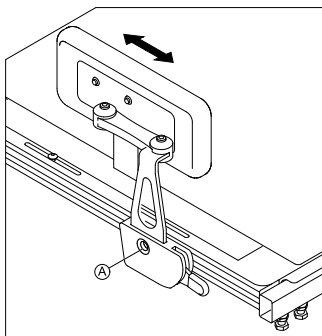

1. Loosen screw Ⓐ.
Do not remove it.
2. Adjust hip support to desired position.
3. Tighten screw.

Adjusting width of hip support

-  Tools
- 2 x 5 mm Allen key

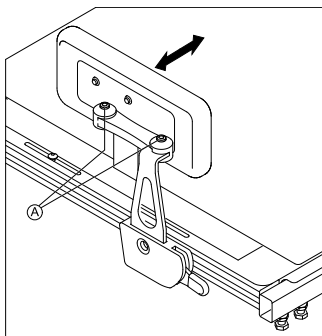

1. Loosen screws Ⓐ.
2. Adjust hip support to desired width.
 You can adjust the width only smaller than the seat width but not wider.
3. Tighten screws.

Adjusting angle of hip support

-  Tools
- 5 mm Allen key

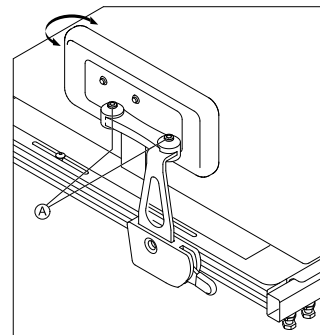

1. Loosen screws Ⓐ.
2. Adjust hip support to desired angle.
3. Tighten screws.

Adjusting hip pad depth

-  Tools
- 10 mm wrench

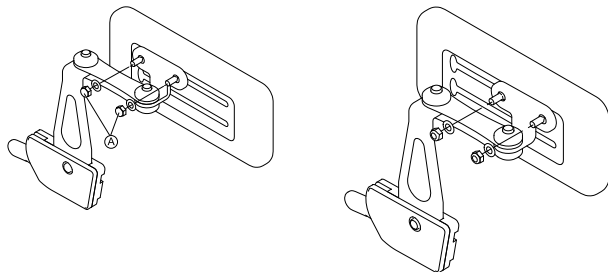

1. Loosen the two screws ①.
2. Adjust hip pad to desired depth.
3. Tighten screws.

Adjusting hip pad height

You can adjust the hip pad height in two ways:

- Via its mounting slots.
- Via its bracket.

Via mounting slots



Tools

- 10 mm wrench

1.

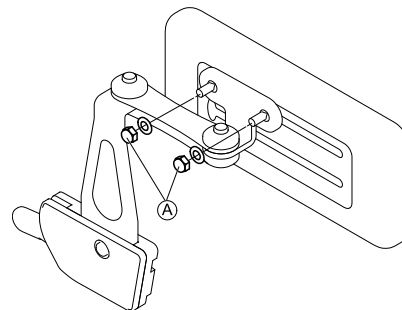

Loosen the two screws ①.

2.

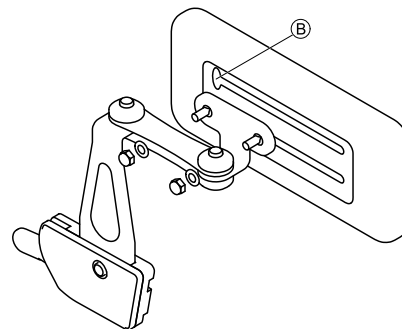

Remove hip pad bracket from mounting slot via cut-out ②.

3. Insert hip pad bracket in other mounting slot.
4. Tighten screws.

Via bracket



Tools

- 5 mm Allen key

1.

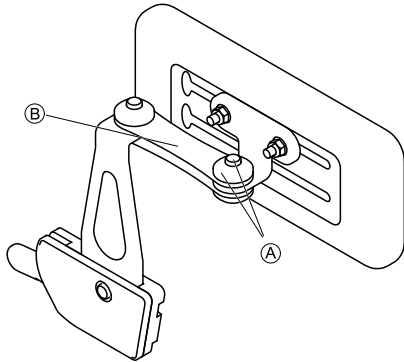

Remove upper screw and friction cap (A).

2. Remove small friction link (B).

3.

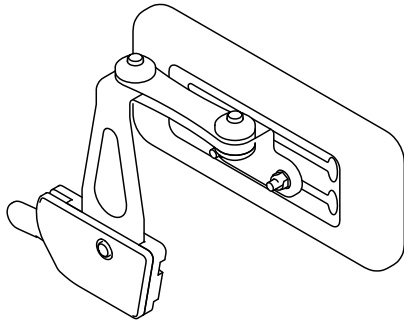

Remove hip pad with bracket, turn upside down and reinstall.

4. Insert friction link, friction cap, screw and tighten.

5.8.10 Adjusting the seat width

The telescopic seat support can be adjusted in four stages. The seat width can thus be adjusted together with the adjustable seat plate or the adjustable sling seat.

The description of how the width is adjusted is contained in the service instructions for this mobility device. The service instructions can be ordered from Invacare. However, they contain instructions for specially trained service technicians and describe operations that are not intended for the end user.

5.8.11 Adjusting the seat depth



The seat depth has a major influence on the selection of the center of gravity of the seat. This impacts its dynamic stability. If you make a major change to the seat depth the center of gravity of the seat must also be adjusted. See "Adjusting the center of gravity of the seat" in the service instructions for this mobility device. The service instructions can be ordered from Invacare. However, they contain instructions for specially trained technicians and describe operations that are not intended for the end user.



The numbers on the scale on the seat serve as a guide. They do not stipulate any dimensions such as seat depth in centimeters.



Tools:

- 6 mm Allen key

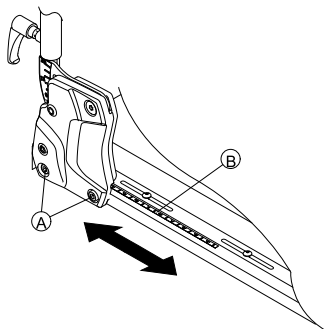

1. On both sides, loosen the bottom backrest screw (A). Do not remove the screws!
2. Move the backrest to the required seat depth. You can adjust the seat depth steplessly. Use scale (B) on the seat as a guide for this purpose. Ensure that the same seat depth is set on both sides.
3. Re-tighten the screws.

5.9 Adjusting the seat angle



CAUTION!

Adjusting the seat tilt or the backrest angle changes the geometry of the mobility device and directly influences its dynamic stability!

– For details regarding dynamic stability, negotiating gradients and obstacles and the correct adjustment of seat tilt or backrest angle, refer to 7.5 *Taking Obstacles*, page 85 and *Driving up and down gradients*.

5.9.1 Electrical

Consult the user manual for your remote for information about electrical adjustment.

5.9.2 Manually using spindle

The seat angle is adjusted by means of a spindle, which is to be found at the front underneath the seat frame.

When adjusting the seat angle it should be ensured that at least 1 cm of the threaded bolt always remains inside the spindle and is not completely unscrewed from the spindle.



It is easier to adjust the angle of the seat when there is nobody sitting in the wheelchair.

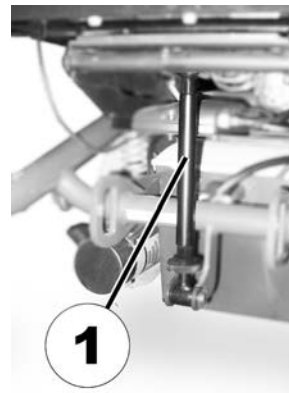

The figure shows the position of the spindle (1) for manual seat angle adjustment.

5.10 Adjusting the backrest



CAUTION!

Adjusting the seat tilt or the backrest angle changes the geometry of the mobility device and directly influences its dynamic stability!

– For details regarding dynamic stability, negotiating gradients and obstacles and the correct adjustment of seat tilt or backrest angle, refer to *7.5 Taking Obstacles, page 85* and *Driving up and down gradients.*

5.10.1 Electrical

Consult the user manual for your remote for information about electrical adjustment.

5.10.2 Adjusting the backrest (standard seat) — manually with handscrews

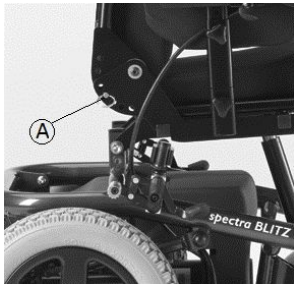

1. Remove splint-pin **A** on both sides of the backrest that hold it in position.
2. Set the backrest to the desired angle by selecting a combination of one of the two holes in the backrest frame, and one of the six holes in the metal fixation plate.
3. Re-position splint-pins **A** and tighten them.

5.10.3 Adjusting the back seat angle on the Easy-Adapt seating system



1. Adjust the angle by turning the hand wheel (1).

5.10.4 Adjusting the height of the backrest (Modulite seat unit)

The following section describes the procedures for adjusting the height of the backrest plate.



The sling back is only available in fixed heights of 48 and 54 cm.



- 5 mm Allen key

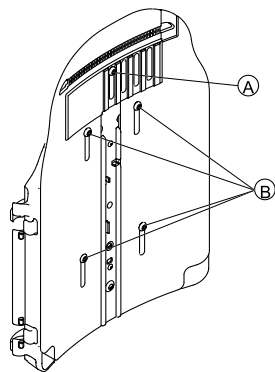

1. Loosen the backrest plate screws Ⓐ and Ⓑ.
Do not remove the screws!
2. Move the backrest plate to the required height.
3. Re-tighten the screws.

5.10.5 Adjusting the width of the backrest (Modulite seat unit)

You can adjust the backrest plate width to a certain degree by adjusting the front plate, e.g. in order to adjust the backrest plate in line with the seat cushion. Fairly large adjustments must be made by a service technician to the rear plate and are outlined in the service instructions for this mobility device.



The sling back is only available in two widths of 38-43 cm and 48-53 cm and, under certain circumstances, must be replaced for a width adjustment. For a replacement description, see the service instructions for this mobility device. The service instructions can be ordered from Invacare. However, they contain instructions for specially trained service technicians and describe operations that are not intended for the end user.

Note that if the sling back width is adjusted the backrest cushion must also be replaced.



- 5 mm Allen key

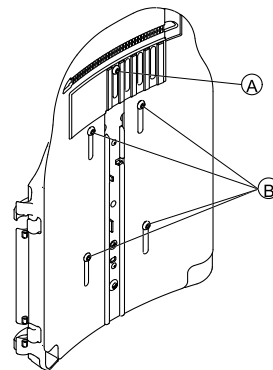

1. Loosen and remove the backrest plate screw Ⓐ.
2. Loosen the backrest plate screws Ⓑ.
Do not remove the screws!
3. Move the backrest plate halves to the required width.

4. Re-insert screw (A).
5. Re-tighten the screws.

5.10.6 Adjusting the backrest angle (Modulite seat unit)



CAUTION!

Every change to the seat angle and the backrest angle alters the geometry of the power wheelchair and affects its dynamic stability

- For more information on stability, overcoming obstacles correctly, driving along inclines and slopes and the correct position of the backrest and seat angles, see the section *7.5 Taking Obstacles, page 85* and *Driving up and down gradients*.



CAUTION!

Risk of falling out of the wheelchair

When adjusting the backrest, it might move backward unexpectedly and you might fall out of the wheelchair.

- Do not rest against the backrest while adjusting it.



If the backrest is fitted with knobs instead of Allen screws, you do not need tools.

Width-adjustable backrest



- 6 mm Allen key

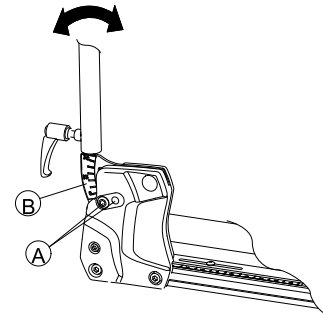

1. On both sides, loosen and remove the upper backrest screw (A).
2. Set the required backrest angle in 3.8° steps. Use scale (B) on the backrest for this purpose. Ensure that you set the same angle on both sides.
3. Re-insert and tighten the screw. Ensure you insert the screw through one of the holes of the backrest bracket. The screw must be visible on the inside of the bracket and the screw head must be flush with the bracket.

Simple backrest



- 6 mm Allen key

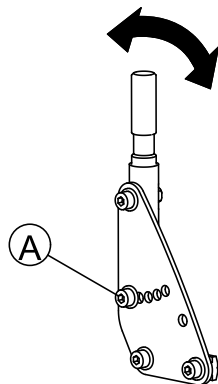

1. On both sides, loosen and remove the middle backrest screw **A**.
2. Set the required backrest angle in 7.5° steps. Ensure that you set the same angle on both sides.
3. Re-insert and tighten the screw.

5.10.7 Adjusting the adaptable backrest padding

There are two ways of adapting the backrest padding.

- Using a snap buckle which is accessible without having to remove the backrest cushion. Please see **Method 1**.
- With adjustment straps which are adjustable using Velcro. Please see **Method 2**.

Method 1

1. Open the Velcro straps on the left-hand side of the backrest cushion.
- 2.

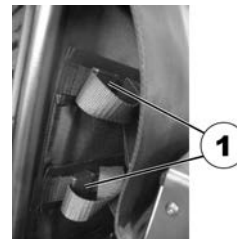

- Open the individual snap buckles (1) on the adjustment straps.
3. Adjust the strap tension as required and then close the snap buckle again.
 4. Close the backrest cushion Velcro fastenings again.

Method 2

1.



Remove the backrest cushion (fixed with Velcro straps) by pulling it up and away so that you can access the adjusting straps.

2.



Adjust the tension of the individual straps as required.

3. Replace the backrest cushion.

5.11 Adjusting the headrest



CAUTION!

Risk of injury during use of the mobility device as a vehicle seat if a headrest is wrongly adjusted or not installed

This can cause the neck to be hyperextended during collisions.

- A headrest must be installed. The headrest optionally supplied for this mobility device by Invacare is perfectly suitable for use during transport.
- The headrest must be adjusted to the user's ear height.

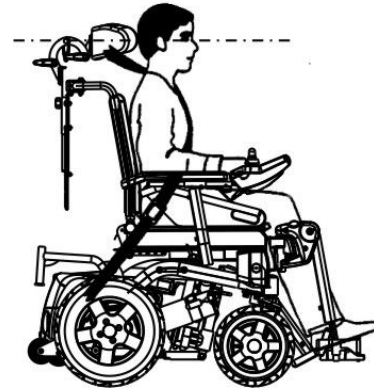

5.11.1 Adjusting the position of the headrest or neckrest

The adjustment of the position is the same for all headrests and neckrests.



- 5 mm Allen key

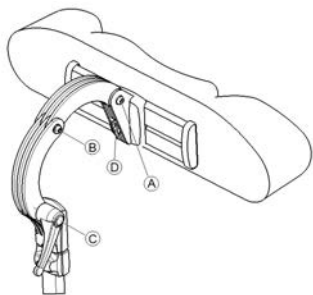

1. Loosen the screws Ⓐ , Ⓑ or the clamping lever Ⓒ.
2. Adjust the headrest or neckrest to the required position.
3. Retighten screws and clamping lever.
4. Loosen the Allen screw Ⓓ.
5. Slide the headrest left or right to the required position.
6. Retighten the Allen screw.

5.11.2 Adjusting the height of the headrest or neckrest

The adjustment of the height is the same for all headrests and neckrests.

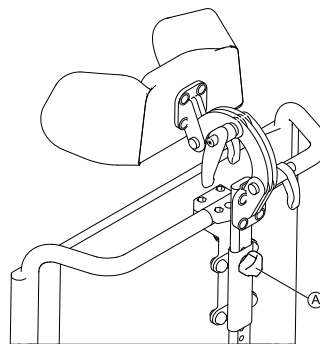

1. Loosen knob Ⓐ.
2. Adjust headrest or neckrest to required height.
3. Retighten knob.

5.11.3 Adjusting the cheek supports



1. Push the cheek supports inward or pull them out to the required position.

5.12 Adjusting the trunk supports

5.12.1 Adjusting the width



1. Loosen the handscrews (1).
2. Adjust the trunk support to the required width.
3. Retighten the handscrews again.

5.12.2 Adjusting the height



Tools:

- 5 mm Allen key



1. Undo the height adjustment Allen screws (1).
2. Set the trunk support to the required height.
3. Retighten the screws.

5.12.3 Adjusting the depth



Tools:

- 5 mm Allen key



1. Open the zip.
2. Undo the screws (1) for the depth adjustment.
3. Adjust the trunk support to the required position.
4. Retighten the screws.
5. Close the zip again.

5.13 Adjusting and removing the tray



CAUTION!

Risk of injury or material damage if a mobility device which is fitted with a tray is transported in a vehicle

– If a tray is fitted, always remove it before transporting the mobility device.



5.13.1 Laterally adjusting the tray

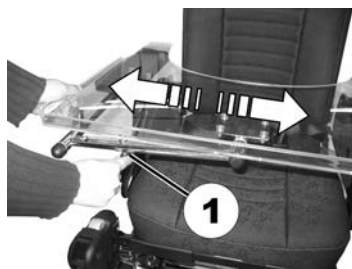

1. Loosen wing-screw (1).
2. Adjust tray towards the left or right.
3. Re-tighten wing-screw.

5.13.2 Adjusting the depth of the tray / removing the tray

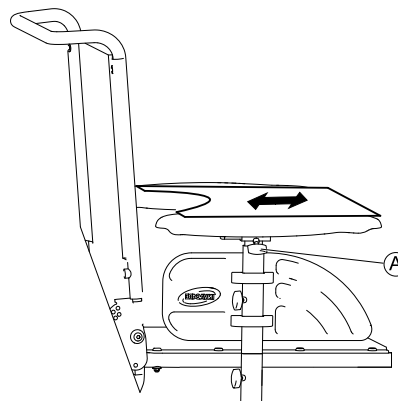

1. Loosen wing-screw (A).
2. Adjust tray to desired depth (or remove it entirely).
3. Re-tighten screw.

5.13.3 Swinging the tray away to the side

The tray can be swivelled up and away to the side to allow the user to get in and out of the mobility device.



CAUTION!

Risk of injury! When the tray is raised it does not lock in place in this position!

- Do not tilt the tray up and leave it leaning in this position.
- Never attempt to drive with the tray tilted up.
- Always lower the tray in a controlled manner.

5.14 Seat support

5.14.1 Adjusting seat width



Also refer to the following chapter entitled 5.14.2 *Adjusting the seat depth, page 59.*

The seat width can be adjusted in stages between 380 and 530 mm.



Tools:

- 4 mm Allen key

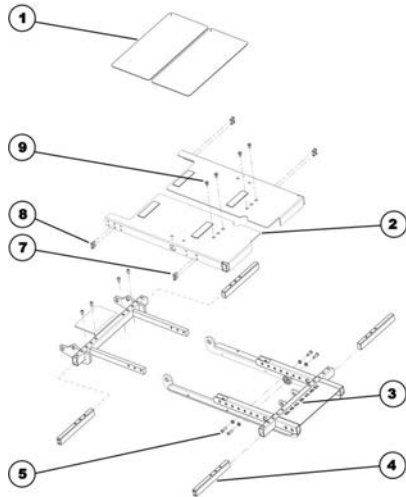

Fig. 5-1 Exploded drawing of seat support

1. Remove the seat cushion.
2. Remove the cover plates (1).

3. Undo the two Allen screws (6) at the rear on the crossmember and remove them.
4. Undo the two Allen screws (9) at the front on the seat support plate and remove them.
5. Loosen the four Allen screws (7) and (8) which are located at the front and back to the sides of the seat support plate to release tension so that the plate can be moved more easily. Do not, however, remove these screws completely.
6. Pull or push the seat support plate (2) the required width. A scale (3) has been fitted to the bottom part of the seat support. Use this scale to read off the seat width in centimeters.
7. Repeat these operations on the other side of the seat.
8. Now tighten all the screws again.

5.14.2 Adjusting the seat depth



Also refer to the previous chapter entitled 5.14.1 *Adjusting seat width, page 59.*

The seat depth can be adjusted in stages between 380 and 530 mm.



Tools:

- 4 mm Allen key
- 8 mm jaw spanner
- oblique pliers
- cable binder



Particular holes in the seat support must be used to the screws depending on the required seat depth. It may also be necessary to replace the seat support plate.

- Please use the following figures and the table to determine which holes need to be used for the required seat depth, and therefore whether the seat support plate needs to be replaced or not.

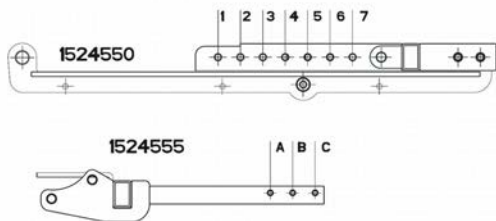

Seat depth in cm	Holes used in front seat frame order no.: 1524550	Holes used in rear seat frame order no.: 1524555	Seat support plate required
38	6 & 7	A & B	SHORT order no. 1526437
41	5 & 7	A & C	
43	4 & 6	A & C	
43	4 & 6	A & C	MEDIUM order no. 1526438
46	3 & 5	A & C	
48	2 & 4	A & C	

Seat depth in cm	Holes used in front seat frame order no.: 1524550	Holes used in rear seat frame order no.: 1524555	Seat support plate required
48	2 & 4	A & C	LONG order no. 1526439
51	1 & 3	A & C	
53	1 & 2	B & C	

- Adjust the seat depth as described in the following chapter:
 - If the seat support plate does not need to be replaced, please refer to chapter 5.14.3 *Adjusting the seat depth without replacing the seat support plate*, page 61.
 - If the seat support plate does need to be replaced, please refer to chapter 5.14.4 *Adjusting the seat depth with replacing the seat support plate*, page 62.

5.14.3 Adjusting the seat depth without replacing the seat support plate

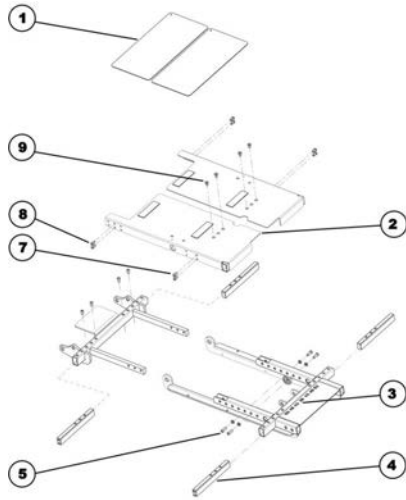

Fig. 5-2 Exploded drawing of seat support

Disassembly

1. Remove the armrests.
2. Remove the seat cushion.
3. Remove the cover plates (1).
4. Undo and remove the two Allen screws (8) which are located on the side at the rear of the seat support plate, and connect these to the crossmembers (4).
5. Repeat these operations on the other side of the seat.
6. Undo and remove the two Allen screws (5) including washers.

Assembly

1. Pull the seat support to the required length so that the Allen screws (5) can be inserted in the holes in accordance with the table (see above).
2. Insert the Allen screws (5) including washers again and tighten them.
3. Fit the two Allen screws (8) which are located at the rear of the seat support, and connect them with the crossmembers (4). You must be using other holes within the 3 hole pairs for the screws than you did during dismantling.
4. Refit all the parts you have removed.

5.14.4 Adjusting the seat depth with replacing the seat support plate

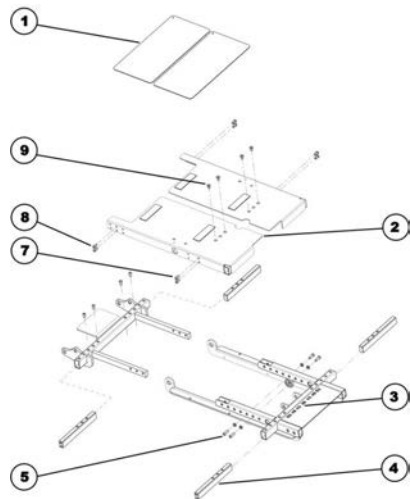

Fig. 5-3 Exploded drawing of seat support

Disassembly

1. Remove the legrests.
2. Remove the armrests.
3. Remove the seat cushion.
4. Remove any cable ties which hold cables from the remote or lighting which have been fitted. Remove the cables from any clips which have been glued on.
5. Undo the cap nuts on the headlight holders with an 8 mm jaw spanner.
6. Place the headlights including their holders safely on the rear section of the battery box cover.

7. Remove the cover plates (1).
8. Undo the two Allen screws (9) at the front on the seat support plate and remove them.
9. Undo the two Allen screws (7) which are located on the side at the front of the seat support plate, and connect these to the crossmembers (4).
10. Undo the two Allen screws (8) which are located on the side at the rear of the seat support plate, and connect these to the crossmembers (4).
11. Remove the seat support plate (2).
12. Repeat these operations on the other side of the seat.
13. Undo and remove the two Allen screws (5) including washers.

Assembly

1. Pull the seat support to the required length so that the Allen screws (5) can be inserted in the holes in accordance with the table (see above).
2. Insert the Allen screws (5) including washers again and tighten them.
3. If necessary, replace the seat support plate (2) in accordance with the table (see above).
4. Put the seat support plate (2) back in position.
5. Fit the two Allen screws (7) which are located at the front of the seat support, and connect them with the crossmembers (4).
6. Fit the two Allen screws (8) which are located at the rear of the seat support, and connect them with the crossmembers (4). It may be necessary to use other holes in the 3 hole pairs for the screws than you did while dismantling the old plate.

7. Fit the two Allen screws (9) at the front of the seat support plate.
8. Refit all the parts you have removed.

5.15 Backrest unit with ergonomic length compensation (Easy-Adapt)

5.15.1 Adjusting the width

 Also refer to the previous chapter entitled *5.14.1 Adjusting seat width, page 59.*

The seat can be adjusted in stages between 380 and 530 mm.



Tools:

- 4 mm Allen key

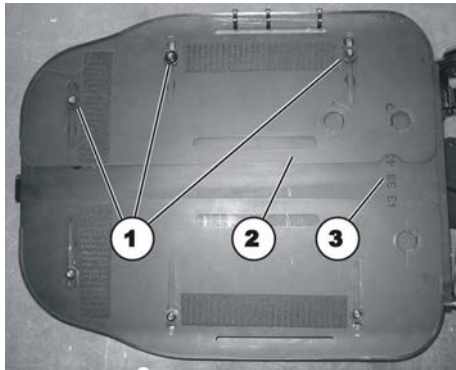

1. Remove the backrest cushion.
2. Loosen the three Allen screws (1). Do not, however, remove these screws completely.

3. Push the plate (2) as far as required until the required width in cm can be read off the scale (3).
4. Tighten the three Allen screws again.
5. Repeat these operations on the other backrest plate.
6. Attach a backrest cushion of the required width.

5.16 Adjusting the suspension and the shock absorbance

Taking the user weight into account, the Storm^{®4} suspension and shock absorbance can be individually adjusted to a softer setting for more comfort and less shock absorbance or a harder setting for a harder suspension and more support. These adjustments should only be carried out by trained specialists. Contact your authorized Invacare specialist dealer.



It is easier to adjust the suspension and shock absorbance if there is no-one sitting in the chair.

5.16.1 Adjusting the suspension (Storm®4 X-plore only)

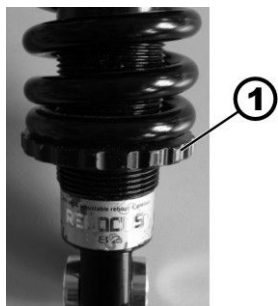

Softer



Harder

Adjusting the suspension harder

1. Rotate the adjustable spring plate (1) as shown in the illustration in order to adjust the suspension harder.

Adjusting the suspension softer

1. Rotate the adjustable spring plate (1) as shown in the illustration in order to adjust the suspension softer.

5.16.2 Disabling the suspension and shock absorbance

You can disable the suspension and shock absorbance so that they are no longer working.

- 1.

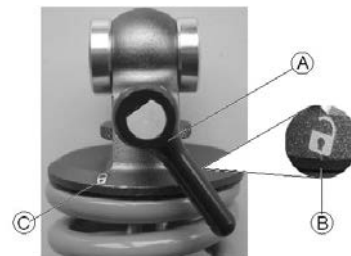

Move the lever (A) from "Active" ("open lock" symbol, B) to "Inactive" ("closed lock" symbol, C).



The suspension and shock absorbance are disabled.

5.16.3 Adjusting the shock absorbance

In the case of the Storm®4 X-plore, the shock absorbance can be quickly and simply adjusted using a wheel on the springs:

- If you set the shock absorber harder, you get a more direct response to the ground for more sportive driving with a less swinging chassis.
- The softer you set the shock absorber, the softer the response to the ground is and the more comfortable the driving is.



Fig. 5-4 Left



Fig. 5-5 Right

The works setting for the wheel is the middle position. From here, the shock absorber can be adjusted to be softer (-) or harder (+) in 10 levels in either direction.

Adjusting the shock absorber harder

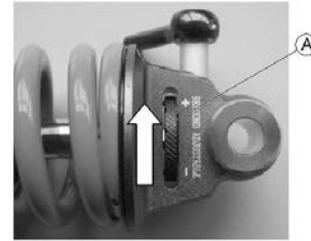

1. Turn the wheel **A** to the plus sign, to set harder shock absorber.
10 is the hardest level of shock absorber.

Adjusting the shock absorber softer

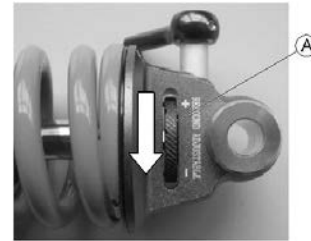

1. Turn the wheel **A** to the minus sign, to set softer shock absorber.
10 is the softest level of shock absorber.

5.17 Center-mounted legrests — Electric legrest

Consult the user manual for your remote for information about electrical adjustment.

The electric legrest can be lowered completely to assist getting out of the wheelchair. To do so, move your seat into the correct position by lowering the lifter or by means of a negative seat angle (tilted slightly to the front).

5.17.1 Lowering the electric legrest completely to assist getting out of the wheelchair

- ! **Misuse may destroy the legrest**
 - Please read and carefully follow the instructions below.

Getting in/out of the wheelchair

1. Set the lifter and tilt to a comfortable position.
- 2.



Put your feet on the footplate and pull the lever (1). The footplates will move smoothly down to the floor.

3. Now you can get in/out of the wheelchair.

Lifting up the footplates

1. You are sitting in the wheelchair.
- 2.



Put your feet beside the footplates

- 3.



Pull the lever (1).

The footplates rise up automatically.

4. Let go the lever (1) and put your feet on the footplates.

Adjusting the legrest



Risk of damage to the legrest

- Always make sure that the footplates are fully raised to the uppermost position before adjusting the angle of the legrest.
- Disregarding this advice will cause damage to your legrest.



1. Now you can adjust the angle of the legrest.

5.18 Center-mounted legrests — Adjustable legrest

5.18.1 Adjusting the angle



Tools:

- 10 mm wrench

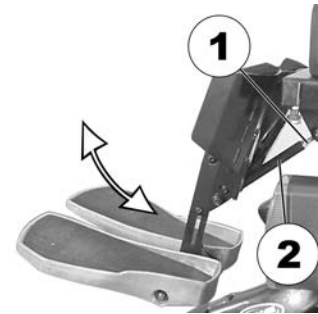

1. Loosen the counter nut (1).
2. Move the legrest to the desired position by turning the spindle (2).
3. Tighten the counter nut.

5.18.2 Adjusting the length of the legrest



Tools:

- 5 mm wrench

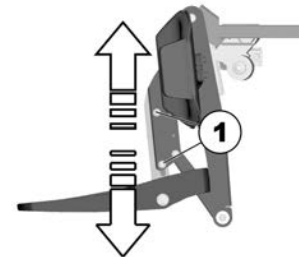

1. Loosen the fastening screws (1).
2. Slide the foot support to the desired height.
3. Tighten the fastening screws.

5.18.3 Adjusting the calf pad to the calf width of the user

The calf pad of the legrest can be adapted to the user's calf width by bending apart or together.



1. Bending the calf pad to the desired width.

5.18.4 Adjusting the angle of the foot plate



Tools:

- 5 mm wrench



1. Fold up the foot plates in order to access the adjusting screws.
2. Adjust the adjusting screws (1).
3. Fold the foot plate down again.

5.19 Vari-F footrest

5.19.1 Swivelling the footrest/legrest outward and/or removing

The small unlocking button is located on the upper section of the footrest/legrest. When the footrest/legrest is unlocked, it can be swivelled inward or outward when getting into the wheelchair as well as being removed completely.



1. Press the unlocking button (1) and swivel the footrest/legrest outward.
2. Remove the footrest/legrest in an upward direction.

5.19.2 Setting the angle



CAUTION!

Risk of injury due to incorrect adjustment of the footrests and legrests

- Before and during every journey it is imperative to ensure that the legrests contact neither the caster wheels nor the ground.



- 6 mm Allen key

1.

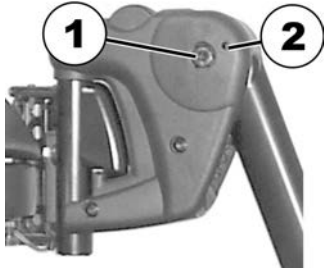

Loosen the screw (1) using the Allen key.

2. If the footrest cannot be moved after loosening the screw, position a metal pin in the designated borehole (2) and use a hammer to knock on this lightly. The clamping mechanism in the interior of the footrest will be released by this. Repeat the procedure from the other side of the footrest if necessary.

3.

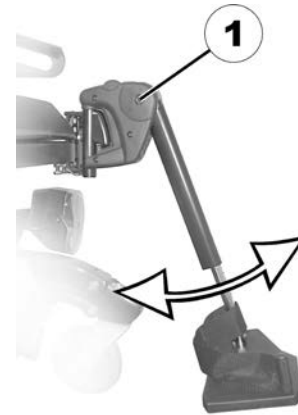

Loosen the screw (1) using the Allen key.

4. Set the desired angle.
5. Re-tighten the screw.

5.19.3 Setting the end stop of the footrest



- 6 mm Allen key
- 10 mm wrench

1.



The end position of the footrest is determined by means of a rubber stop (1).

2.

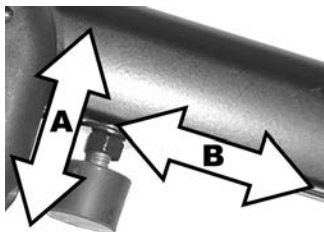

The rubber stop can be screwed in or out (A) or pushed up or down (B).

3.



Use the Allen key to loosen the screw (1) and swivel the footrest upward in order to access the rubber stop.

4.



Use the open-ended spanner to loosen the counter nut (1).

5.

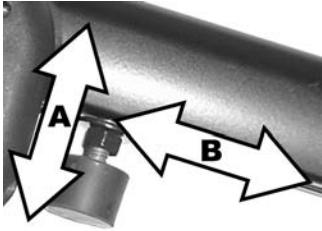

Move the rubber stop to the desired position.

6. Re-tighten the counternut.

7.



Move the footrest to the desired position.

8. Re-tighten the screw.

5.19.4 Adjusting the length of the footrest



CAUTION!

Risk of injury due to incorrect adjustment of the footrests and legrests

– Before and during every journey it is imperative to ensure that the legrests contact neither the caster wheels nor the ground.



- 5 mm Allen key



1. Use the spanner to loosen the screw (1).
2. Adjust to the desired length.
3. Re-tighten the screw.

5.20 Vari-A legrests

5.20.1 Swivelling the footrest/legrest outward and/or removing

The small unlocking button is located on the upper section of the footrest/legrest. When the footrest/legrest is unlocked,

it can be swivelled inward or outward when getting into the wheelchair as well as being removed completely.

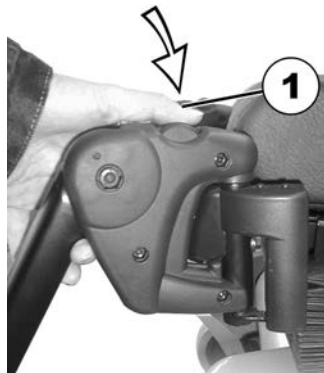

1. Press the unlocking button (1) and swivel the footrest/legrest outward.
2. Remove the footrest/legrest in an upward direction.

5.20.2 Setting the angle



CAUTION!

Risk of injury due to incorrect adjustment of the footrests and legrests

- Before and during every journey it is imperative to ensure that the legrests contact neither the caster wheels nor the ground.

1.

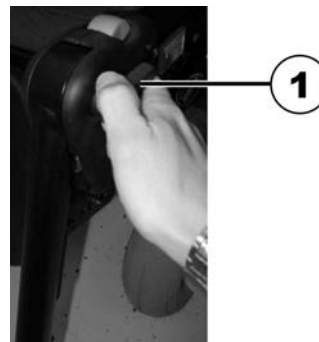

Loosen the locking knob (1) counter-clockwise at least one turn.

2.



Hit the knob to release the locking mechanism.

3.



Set the desired angle.

4.



Turn the knob clockwise to tighten it.

5.20.3 Setting the end stop of the legrest



- 10 mm wrench

1.



The end position of the legrest is determined by means of a rubber stop (1).

2.

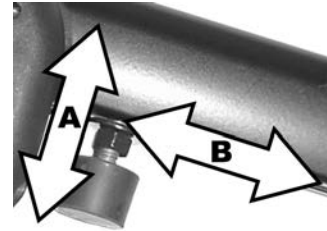

The rubber stop can be screwed in or out (A) or pushed up or down (B).

3.

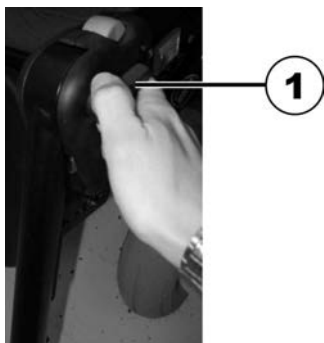

Loosen the locking knob (1) counter-clockwise at least one turn.

4.



Hit the knob to release the locking mechanism.

5.



Swivel the legrest upward in order to access the rubber stop.

6.



Use the wrench to loosen the conical nut (1).

7.

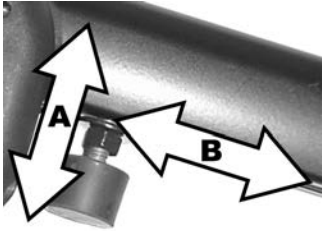

Move the rubber stop to the desired position.

8. Re-tighten the counternut.

9.



Move the legrest to the desired position.

10. Re-tighten the locking knob.

5.20.4 Adjusting the length of the legrest



CAUTION!

Risk of injury due to incorrect adjustment of the footrests and legrests

– Before and during every journey it is imperative to ensure that the legrests contact neither the caster wheels nor the ground.



- 5 mm Allen key

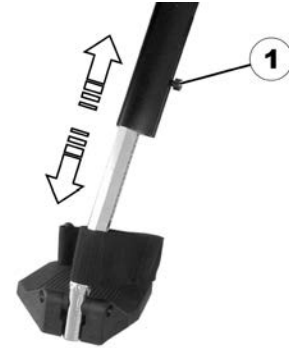

1. Use the spanner to loosen the screw (1).
2. Adjust to the desired length.
3. Re-tighten the screw.

5.20.5 Adjusting the depth of the calf pad

The depth of the calf pad can be adjusted via the holding plate. The holding plate hole combinations allow 5 different depth settings.



- 10 mm wrench

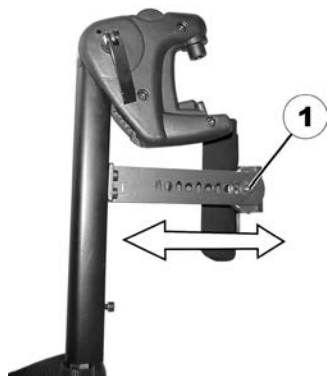

1. Use the wrench to loosen the nut (1) and remove.
2. Adjust to the desired depth. Observe that the round holes are intended for the calf pad retaining screw and the oblong holes for the aglet without thread.
3. Screw the nut back on and tighten.

5.20.6 Adjusting the height of the calf pad



- 4 mm Allen key



1. Use the Allen key to loosen the screws (1).
2. Adjust to the desired position.
3. Re-tighten the screws.

5.20.7 Unlocking and swivelling the calf pad backward when alighting

- 1.



Press the calf pad straight down.

- 2.



Unlock the legrest and swivel outward.
The calf pad swivels backward on its own.

3.



Lift leg over the heel strap and place on the ground.

5.20.8 Adjusting the angle-adjustable foot plate



- 5 mm Allen key

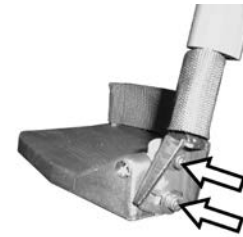

1. Use the Allen key to loosen both set screws on the foot plate.
2. Adjust to the desired angle.
3. Re-tighten the screws.

5.20.9 Adjusting the angle- and depth-adjustable foot plate



- 5 mm Allen key



1. Use the Allen key to loosen the set screw on the foot plate (1).
2. Adjust the foot plate to the desired angle or depth.
3. Re-tighten the screw.

5.21 Powered elevating legrests (ADE legrests)

5.21.1 Swivelling the legrest outward and/or removing

The small unlocking button is located on the upper section of the legrest. When the legrest is unlocked, it can be swivelled inward or outward when getting into wheelchair as well as being removed completely.



1. Press the unlocking button (1) and swivel the legrest outward.
2. Remove the legrest in an upward direction.

5.21.2 Setting the angle



CAUTION!

Risk of crushing

- Do not reach inside the swivelling range of the legrest.



CAUTION!

Risk of injury due to incorrect adjustment of the footrests and legrests

- Before and during every journey it is imperative to ensure that the legrests contact neither the caster wheels nor the ground.

The electrically height-adjustable legrests are operated using the remote. Refer to the separate user manual for your remote for more information.

5.21.3 Adjusting the length of the legrest



CAUTION!

Risk of injury due to incorrect adjustment of the footrests and legrests

- Before and during every journey it is imperative to ensure that the legrests contact neither the caster wheels nor the ground.



- 10 mm wrench

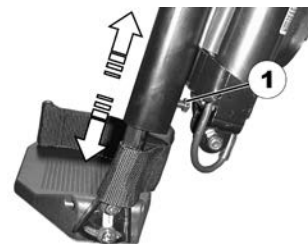

1. Use the wrench to loosen the screw (1).
2. Adjust to the desired length.
3. Re-tighten the screw.

5.21.4 Adjusting the depth of the calf pad

The depth of the calf pad can be adjusted via the holding plate. The holding plate hole combinations allow 5 different depth settings.

-
- 
- 10 mm wrench
-

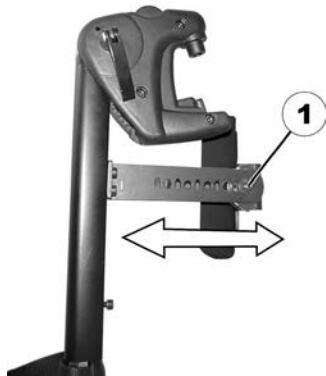

1. Use the wrench to loosen the nut (1) and remove.
2. Adjust to the desired depth. Observe that the round holes are intended for the calf pad retaining screw and the oblong holes for the aglet without thread.
3. Screw the nut back on and tighten.

5.21.5 Adjusting the height of the calf pad

-
- 
- 4 mm Allen key
-



1. Use the Allen key to loosen the screws (1).
2. Adjust to the desired position.
3. Re-tighten the screws.

5.21.6 Unlocking and swivelling the calf pad backward when alighting

- 1.



- Press the calf pad straight down.
- 2.



Unlock the legrest and swivel outward.
The calf pad swivels backward on its own.

3.



Lift leg over the heel strap and place on the ground.

5.21.7 Adjusting the angle-adjustable foot plate



- 5 mm Allen key



1. Use the Allen key to loosen both set screws on the foot plate.
2. Adjust to the desired angle.
3. Re-tighten the screws.

5.21.8 Adjusting the angle- and depth-adjustable foot plate



- 5 mm Allen key

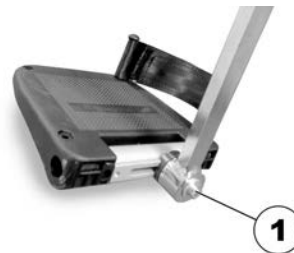

1. Use the Allen key to loosen the set screw on the foot plate (1).
2. Adjust the foot plate to the desired angle or depth.
3. Re-tighten the screw.

5.22 Angle-adjustable footboard



Tools:

- T25 Torx spanner
- 5 mm Allen key

1.



Release the screws (1) with the Torx spanner and remove.

2. Adjust to required width.
3. Retighten the bolts.
4. Glue the anti-slip rubber mat to the footboard.
- 5.



Loosen the locking screw(1) on both sides with the mm Allen key.

6. Adjust the footboard to the required angle.
7. Retighten the bolts.

1529686-S

5.23 Adjusting the width of side-mounted legrests



Tools:

- 13 mm wrench

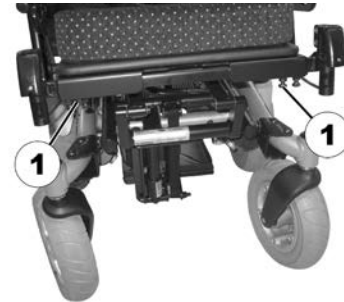

The screws that allow width adjustment of side-mounted legrests are located under the seat (1).

1. Loosen the screws using the wrench.
2. Adjust the legrest to the desired position.
3. Re-tighten the screws.

6 Adjusting the mobility device to the user's seating posture

7 Usage

7.1 Driving



The maximum load capacity that is stated in the technical data only states that the system is designed for this mass in total. However, this does not mean that one can sit a person with this body weight in the mobility device without restrictions. Attention must be paid to the body proportions, such as height, weight distribution, abdominal belt, leg and calf strap and seat depth. These factors have a strong influence on driving features such as tilt stability and traction. The permissible axle loads in particular must be adhered to (refer to *12 Technical data, page 112*). It may possibly be necessary to carry out adaptations to the seat system.

7.2 Before driving for the first time

Before you take your first trip, you should familiarize yourself well with the operation of the mobility device and with all operating elements. Take your time to test all functions and driving modes.



If installed, make sure to properly adjust and use the posture belt each time you use the mobility device.

Sitting comfortably = Driving safely

Before each trip, make sure that:

- You are within easy reach of all operating controls.
- The battery charge is sufficient for the distance intended to be covered.

- The posture belt (if installed) is in perfect order.
- The rear mirror (if installed) is adjusted so you can look behind at all times without having to bend forward or shift your seating position.

7.3 Parking and stationary

When parking your vehicle or if your vehicle is stationary for a prolonged period:

1. Switch the vehicle's power system off (ON-/OFF key).
2. Activate your anti-theft lock, if existing.

7.4 Getting in and out of the mobility device



– The armrest must be removed or swiveled up in order to get into or out of the mobility device from the side.

7.4.1 Removing the standard armrest in order to side transfer

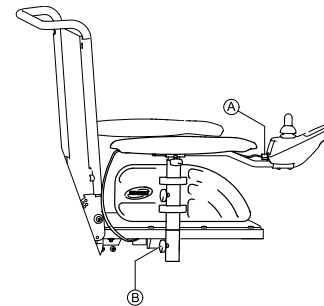

1. Pull the plug **(A)** of the remote cable to disconnect the remote.
2. Loosen wing nut **(B)**.
3. Remove the armrest from the holder.

7.4.2 Information about getting in and out



WARNING!

Risk of serious injury or damage

Improper transfer techniques may cause serious injury or damage

- Before attempting transfers, consult a healthcare professional to determine proper transfer techniques for the user and type of wheelchair.
- Follow the instructions below.



If you do not have sufficient muscle strength, you should ask other persons for help. Use a sliding board, if possible.

Getting into the mobility device:

1. Position your mobility device as close as possible to your seat. This might have to be done by an attendant.
2. Align casters parallel to the drive wheels to improve stability during transfer.
3. Always switch your mobility device off.

4. Always engage both motor locks/clutches and free wheel hubs (if fitted) to prevent the wheels from moving.
5. Depending on the armrest type of your mobility device, detach the armrest or swivel it up.
6. Now slide into the mobility device.

Getting out of the mobility device:

1. Position your mobility device as close as possible to your seat.
2. Align casters parallel to the drive wheels to improve stability during transfer.
3. Always switch your mobility device off.
4. Always engage both motor locks/clutches and free wheel hubs (if fitted) to prevent the wheels from moving.
5. Depending on the armrest type of your mobility device, detach the armrest or swivel it up.
6. Now slide onto your new seat.

Swivelling Nucleus Midline Holder to Side

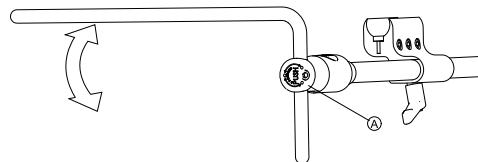

1. Push button **(A)** and swivel up or down nucleus.

Swivelling Swing-Away Display Holder to Side



The swing-away display holder only locks in place when swivelled to its default position.

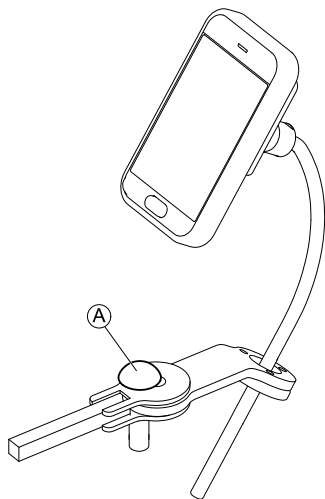

1. Push knob **A** and swivel display holder to side.

Swivelling Chin Control to Side

- 1.

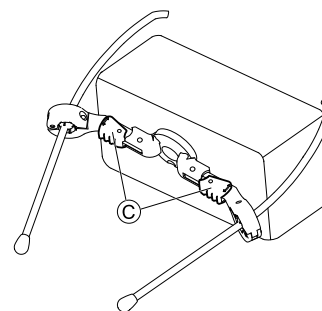

Press locking device **C** (behind headrest) and swivel joystick or egg switch inwards or outwards until it clicks in place.

7.5 Taking Obstacles

7.5.1 Maximum obstacle height

You can find information about maximum obstacle heights in the chapter entitled *12 Technical data, page 112*

7.5.2 Safety information when taking obstacles



CAUTION!

Risk of tipping over

- Never approach obstacles at an angle but at 90 degrees as shown below.
- Approach obstacles followed by a gradient with caution. If unsure whether the gradient is too steep or not, move away from the obstacle and if possible try to find another location.
- Never approach obstacles on an uneven and/or loose ground.
- Never drive with too low tire pressure.
- Put your backrest into an upright position before ascending an obstacle.



CAUTION!

Risk of falling out of the mobility device and damage to the mobility device such as broken casters

- Never approach obstacles that are higher than the maximum climbable obstacle height.
- Never let the footrest/legrest touch the ground when descending an obstacle.
- If unsure whether taking an obstacle is possible or not, move away from the obstacle and if possible find another location.

7.5.3 The correct way to take obstacles



The following instructions how to take obstacles also apply for attendants if the mobility device is fitted with an attendant control.

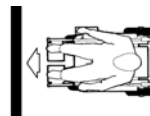

Fig. 7-1 Right



Fig. 7-2 Wrong

Ascending

1. Approach the obstacle or the curb slowly, head-on and at a right angle.
2. Depending on the wheel drive type, stop in one of the following positions:
 - a. In the case of centrally driven mobility devices: 5 - 10 cm before the obstacle.
 - b. For all other drives: approx. 30 - 50 cm in front of the obstacle.
3. Check the position of the front wheels. They must be in driving direction and at right angles to the obstacle.
4. Approach slowly and keep at a consistent speed until the rear wheels have also passed over the obstacle.

Ascending obstacles with a curb climber

1. Approach the obstacle or the curb slowly, head-on and at a right angle.
2. Stop in the following position: 30 – 50 cm in front of the obstacle.
3. Check the position of the front wheels. They must be in driving direction and at right angles to the obstacle.
4. Approach with full speed until the curb climber makes contact with the obstacle. The impetus will lift both front wheels over the obstacle.
5. Keep at a consistent speed until the rear wheels have also passed over the obstacle.

Descending

The approach to descend an obstacle is the same as to ascend it with the difference that you need not to stop before descending.

1. Descend the obstacle with medium speed.

 When descending an obstacle too slowly it could happen that the antitippers get stuck and lift the drive wheels off the ground. Driving the mobility device is then no longer possible.

7.6 Driving up and down gradients

For information concerning the rated slope, refer to 12 *Technical data, page 112*



CAUTION!

Risk of tipping over

- Only ever drive downhill at a maximum of 2/3 of the top speed. Avoid sudden changes of direction or abrupt braking when driving on slopes.
- Always return the backrest of your seat or the seat tilt (if adjustable seat tilt is available) to an upright position before ascending slopes. We recommend that you position the seat backrest or the seat tilt slightly to the rear before descending slopes.
- Always lower the lifter (if fitted) to its lowest position before ascending or descending a slope.
- Never attempt to ascend or descend a slope on slippery surfaces or where there is a risk of skidding (such as wet pavement, ice etc).
- Avoid trying to get out of the vehicle on an incline or a gradient.
- Always drive straight in the direction the road or path you are on goes, rather than attempting to zigzag.
- Never attempt to turn around on an incline or a slope.



CAUTION!

Braking distance is much longer on a downhill slope than on even terrain

- Never drive down a slope that exceeds the rated slope (refer to 12 *Technical data, page 112*).



Important information about regulating the actuator functions on gradients

– Your mobility device is fitted with an angle sensor which guarantees tipping stability. The sensor measures the actual angle of the drive unit, and prevents any further decrease in stability by restricting the functionality of the adjustment actuators. If this safety function is activated, the backrest and the seat tilting can only be moved forwards, and the lifter can only be lowered. Reposition your mobility device on level ground so that the actuators can function normally again.

7.7 Using foldable antitippers

Where space is restricted, e.g. in an elevator or when being transported in a car, the mobility device may be too long. Foldable antitippers can be useful here. These can only be operated by an attendant as they are positioned beyond the reach of the user.



CAUTION!

Risk of tipping if the antitippers are not returned to the driving position before moving off

- Always return the antitippers to the driving position before moving off (see the figure below).
- Make sure that the locking pin is fully engaged.

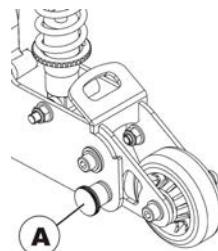

Fig. 7-3 Driving position

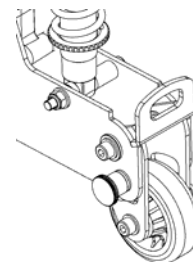

Fig. 7-4 Parking position

Folding the antitipper down:

1. Pull out the locking pin **A** to release the antitipper.
2. Fold the antitipper down.
The mobility device is now shorter.

Folding the antitipper up:

1. Fold the antitipper upwards until the locking pin audibly engages.
The antitipper is functional again.

7.8 Use on public roads

If you wish to use your mobility device on public roads and lighting is required by national legislation, then your mobility device needs to be fitted with an appropriate lighting system.

Contact your Invacare provider if you have any questions.

7.9 Pushing the mobility device in freewheel mode

The motors of the mobility device are equipped with automatic brakes, preventing that the mobility device starts

rolling out of control when the remote is switched off. When pushing the mobility device manually whilst freewheeling, the magnetic brakes must be disengaged.

 Pushing the mobility device by hand may require more physical force than expected (more than 100 N). The necessary force nevertheless complies with the requirements of ISO 7176-14.

 The intended use of the freewheel mode is to maneuver the mobility device over short distances. The push handles or push bars support this function, but be aware that there might be some impairment between the feet of the assistant and the rear part of the mobility device.

7.9.1 Disengaging motors (conventional motors)



CAUTION!

Risk of injury from hot motor surfaces

– Avoid touching the motor surfaces when engaging or disengaging.



CAUTION!

Risk of the mobility device running away

– When the motors are disengaged (for push operation whilst freewheeling), the electromagnetic motor brakes are deactivated. When the mobility device is parked, the levers for engaging and disengaging the motors must without fail be locked firmly into the "DRIVE" position (electromagnetic motor brakes activated).



The motors may only be disengaged by an attendant, not by the user.

This ensures that the motors are only disengaged if an attendant is available to secure the wheelchair and prevent unintended rolling.

Each motor is fitted with an engaging turn knob which is used to engage or disengage the motor.

Disengaging the motor:



1. Switch off remote.
2. Turn the engaging turn knob  clockwise. The motor is disengaged.

Engaging the motor:

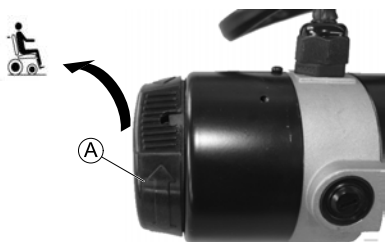

1. Turn the engaging turn knob (A) counterclockwise. The motor is engaged.

 Both motors must always be engaged before driving!

7.9.2 Disengaging the motors (True Track® Plus motors)



CAUTION!

Risk of injury from hot motor surfaces

- Avoid touching the motor surfaces when engaging or disengaging.



CAUTION!

Risk of the mobility device running away

- When the motors are disengaged (for push operation whilst freewheeling), the electromagnetic motor brakes are deactivated. When the mobility device is parked, the levers for engaging and disengaging the motors must without fail be locked firmly into the "DRIVE" position (electromagnetic motor brakes activated).



The motors may only be disengaged by an attendant, not by the user.

This ensures that the motors are only disengaged if an attendant is available to secure the mobility device and prevent unintended rolling.

Each motor is fitted with an engaging lever which is used to engage or disengage the motor.

Disengaging the motor

1. Switch off remote.
- 2.

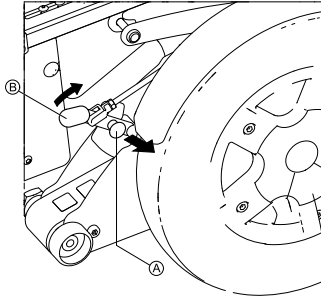

Pull the locking pin **A** out and push the engaging lever **B** forwards.

The motor is now disengaged.

Engaging the motor

- 1.

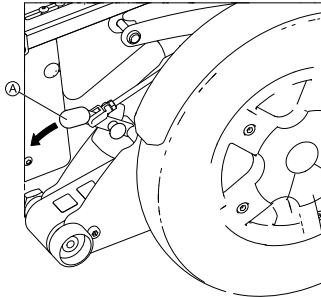

Pull the engaging lever **A** to the rear.

The motor is now engaged.



Note that both motors must always be engaged before driving.

7.10 Imperial to metric conversion chart

You can use this chart as an orientation to find the right tool size.

IMPERIAL	METRIC
inch	mm
5/64	1.9844
3/32	2.3813
7/64	2.7781
1/8	3.1750
9/64	3.5719
5/32	3.9688
11/64	4.3656
3/16	4.7625
13/64	5.1594
7/32	5.5563
15/64	5.9531
1/4	6.3500
17/64	6.7469
9/32	7.1438
19/64	7.5406
5/16	7.9375

IMPERIAL	METRIC
inch	mm
21/64	8.3344
11/32	8.7313
23/64	9.1281
3/8	9.5250
25/64	9.9219
13/32	10.3188
27/64	10.7156
7/16	11.1125
29/64	11.5094
15/32	11.9063
31/64	12.3031
1/2	12.7000
33/64	13.0969
17/32	13.4938
35/64	13.8906
9/16	14.2875
37/64	14.6844
19/32	15.0813
39/64	15.4781

IMPERIAL	METRIC
inch	mm
5/8	15.8750
41/64	16.2719
21/32	16.6688
43/64	17.0656
11/16	17.4625
45/64	17.8594
23/32	18.2563
47/64	18.6531
3/4	19.0500
49/64	19.4469
25/32	19.8438
51/64	20.2406
13/16	20.6375
53/64	21.0344
27/32	21.4313
55/64	21.8281
7/8	22.2250

8 Controls system

8.1 Controls protection system

The wheelchair controls system is fitted with an overload protection.

If the drive is severely overloaded over a long period of time (for example, when driving up a steep hill) and especially when the ambient temperature is high, the controls system could overheat. In this case, the wheelchair performance is gradually reduced until it comes to a halt. The status display shows a corresponding error code (refer to the user manual for your remote). By switching the power supply off and back on again, the error code is cleared and the controls system is switched back on. It can however take up to five minutes until the controls system has cooled down enough for the drive to restore full performance again.

If the drive is stalled by an insurmountable obstacle, for example, a curb or similar which is too high, and the driver attempts driving for more than 20 seconds against this obstacle, the controls system automatically switches off to prevent the motors from being damaged. The status display shows a corresponding error code (refer to the user manual of your remote). By switching off and back on again, the error code is cleared and the controls system is switched back on.



A defective main fuse may be replaced only after checking the entire controls system. A specialized Invacare provider must perform the replacement. You can find information on the fuse type in *12 Technical data, page 112*

8.2 Batteries

Power is supplied by two 12 V batteries. The batteries are maintenance-free and only need regular charging.

In the following, you find information on how to charge, handle, transport, store, maintain, and use batteries.

8.2.1 General information on charging

New batteries should always be fully charged once before their first use. New batteries will be at their full capacity after having run through approx. 10 - 20 charging cycles (break-in period). This break-in period is necessary to fully activate the battery for maximum performance and longevity. Thus, range and running time of your mobility device could initially increase with use.

Gel/AGM lead acid batteries do not have a memory effect as NiCd batteries.

8.2.2 General instructions on charging

Follow the instructions listed below to ensure safe use and longevity of the batteries:

- Charge 18 hours prior to initial usage.
- We recommend charging the batteries daily after every discharge even after partly discharge, as well as each night over night. Depending on the level of discharge, it can take up to 12 hours until the batteries are fully charged again.
- When the battery indicator reached the red LED range, charge the batteries for 16 hours minimum, neglecting the charge complete display!
- Try to provide a 24 hour charge once a week to make sure that both batteries are fully charged.

- Do not cycle your batteries at a low state of charge without regularly recharging them fully.
- Do not charge your batteries under extreme temperatures. High temperatures above 30 °C are not recommended for charging as well as low temperatures below 10 °C.
- Use only charging devices in Class 2. This class of chargers may be left unattended during charging. All charging devices which are supplied by Invacare comply with these requirements.
- You cannot overcharge the batteries when using the charger supplied with your mobility device, or a charger that has been approved by Invacare.
- Protect your charger from sources of heat such as heaters and direct sunlight. If the battery charger overheats, charging current will be reduced and the charging process delayed.

8.2.3 How to charge the batteries

Refer to the user manuals for your remote and battery charger for the position of the charging socket and further information about charging the batteries.



WARNING!

Risk of explosion and destruction of batteries if the wrong battery charger is used

- Only ever use the battery charger supplied with your mobility device, or a charger that has been approved by Invacare.



WARNING!

Risk of electric shock and damage to the battery charger if it gets wet

- Protect the battery charger from water.
- Always charge in a dry environment.



WARNING!

Risk of short circuit and electric shock if the battery charger has been damaged

- Do not use the battery charger if it has been dropped or damaged.



WARNING!

Risk of electric shock and damage to the batteries

- NEVER attempt to recharge the batteries by attaching cables directly to the battery terminals.



WARNING!

Risk of fire and electric shock if a damaged extension cable is used

- Only ever use an extension cable if it is absolutely necessary. In case you must use one, make sure it is in good condition.

**WARNING!****Risk of injury if using the mobility device during charging**

- DO NOT attempt to recharge the batteries and operate the mobility device at the same time.
- DO NOT sit in the mobility device while charging the batteries.

1. Switch off the mobility device.
2. Connect the battery charger to the charger socket.
3. Connect the battery charger to the power supply.

8.2.4 How to disconnect the mobility device after charging

1. Once charging is complete, first disconnect the battery charger from the power supply, then disconnect the plug from the remote.

8.2.5 Storage and Maintenance

Follow the instructions listed below to ensure safe use and longevity of the batteries:

- Always store the batteries fully charged.
- Do not leave the batteries in a low state of charge for an extended length of time. Charge a discharged battery as soon as possible.
- In case your mobility device is not used for a longer period of time (that is more than two weeks), the batteries must be charged at least once a month to maintain a full charge and always be charged before use.
- Avoid hot and cold extremes when storing. We recommend to store batteries at a temperature of 15 °C.

**CAUTION!****Risk of damaging the batteries.**

- Avoid ultra-deep discharges and never drain your batteries completely.

8.2.6 Instructions on using the batteries

- Pay attention to the Battery Charge Indicator! Charge the batteries when the Battery Charge Indicator shows that battery charge is low.
How fast the batteries discharge depends on many circumstances, such as ambient temperature, condition of the surface of the road, tire pressure, weight of the driver, way of driving and utilisation of lighting, if fitted.
- Try to charge the batteries always before you reach the red LED range.
The last 3 LED (two red and one orange) mean a remaining capacity of about 15 %.
- Driving with flashing red LED's means an extreme stress for the battery and should be avoided under normal circumstances.
- When only one red LED is flashing, the Battery Safe feature is enabled. From this time, speed and acceleration is reduced drastically. It will allow you to move the mobility device slowly out of a dangerous situation before the electronic finally cuts off. This is deep discharging and should be avoided.

- Be aware that for temperatures below 20 °C, the nominal battery capacity starts to decline. For example, at -10 °C the capacity is reduced to about 50 % of the nominal battery capacity.
- To avoid damaging the batteries, never allow them to be fully discharged. Do not drive on heavily discharged batteries if it is not absolutely necessary, as this will strain the batteries unduly and shorten their life expectancy.
- The earlier you recharge the batteries, the longer they live.
- The depth of discharge affects the cycle life. The harder a battery has to work, the shorter is its life expectancy. Examples:
 - One deep discharge stresses the same as 6 normal cycles (green /orange display off).
 - The battery life is about 300 cycles at 80 % discharge (first 7 LED off), or about 3000 cycles at 10 % discharge (one LED off).



The number of LED can vary depending on the remote type.

- Under normal operation, once a month the battery should be discharged until all green and orange LED are off. This should be done within one day. A 16 hour charge afterwards is necessary as reconditioning.

8.2.7 Transporting batteries

The batteries supplied with your mobility device are not hazardous goods. This classification is based on the German GGVS Hazardous Goods Road Transport Ordinances, and the IATA/DGR Hazardous Goods Rail Transport / Air Transport Ordinances. Batteries may be transported without

restrictions, whether by road, rail or by air. Individual transport companies have, however, guidelines which can possibly restrict or forbid certain transport procedures. Please ask the transport company regarding each individual case.

8.2.8 General instructions on handling the batteries

- Never mix and match different battery manufactures or technologies, or use batteries that do not have similar date codes.
- Never mix gel with AGM batteries.
- The batteries reach their end of life when the drive range is significantly smaller than usual. Contact your provider or service technician for details.
- Always have your batteries installed by a properly trained mobility device technician or a person with adequate knowledge. They have the necessary training and tools to do the job safely and correctly.

8.2.9 How to handle damaged batteries correctly



CAUTION!

Corrosion and burns from acid leakage if batteries are damaged

- Remove clothes that have been soiled by acid immediately.

After contact with skin:

- Immediately wash affected area with lots of water.

After contact with eyes:

- Immediately rinse eyes under running water for several minutes; consult a physician.

- Always wear safety goggles and appropriate safety clothing when handling damaged batteries.
- Place damaged batteries in an acid-resistant receptacle immediately after removing them.
- Only ever transport damaged batteries in an appropriate acid-resistant receptacle.
- Wash all objects that have come into contact with acid with lots of water.

Disposing of dead or damaged batteries correctly

Dead or damaged batteries can be given back to your provider or directly to Invacare.

9 Transport

9.1 Transport — General information



CAUTION!

Risk of injury or material damage if a mobility device which is fitted with a tray is transported in a vehicle

- If a tray is fitted, always remove it before transporting the mobility device.



9.2 Transferring the mobility device to a vehicle



WARNING!

The mobility device is at risk of tipping over if it is transferred to a vehicle while the user is still seated in the mobility device

- Transfer the mobility device without the user whenever possible.
- If the mobility device with the user has to be transferred to a vehicle using a ramp, ensure that the ramp does not exceed the rated slope (refer to *12 Technical data, page 112*).
- If the mobility device has to be transferred to a vehicle using a ramp that does exceed the rated slope (refer to *12 Technical data, page 112*), a winch must then be used. An attendant can then safely monitor and assist the transfer process.
- Alternatively, a platform lift may be used.
- Ensure that the total weight of the mobility device including the user does not exceed the maximum permitted total weight for the ramp or platform lift.
- The mobility device should always be transferred to a vehicle with the backrest in an upright position, the seat lifter lowered and the seat tilt in the upright position (refer to *Driving up and down gradients*).

**WARNING!****Risk of injury and damage to the mobility device**

If the mobility device is to be transferred to a vehicle via a lift, when the remote is turned on, there is a risk that the device may act erratically and fall off the lift.

- Before transferring the mobility device via a lift, turn off the product and disconnect either the bus cable from the remote or the batteries from the system.

1. Drive or push your mobility device into the transport vehicle using a suitable ramp.

9.3 Use of the mobility device as a seat in a vehicle



The following section does not apply to models or configurations which may not be used as a vehicle seat. These are identified by the following label on the mobility device:

**WARNING!****Risk of death or serious injury**

If a mobility device is secured using a 4-point tie-down system available from a third party supplier and the curb weight of the mobility device exceeds the maximum weight for which the system is certified, death or serious injury to the user and potential nearby occupant.

- The actual weight of this mobility device can exceed 140 kg. Make sure to use a 4-point tie-down system checked and approved in accordance with ISO 10542 and certified for the actual weight of the mobility device. Consult the tie-down system manufacturer's documentation.
- If compatible, use the Docking Station system (available separately) as an alternative way to safely use this mobility device as a vehicle seat. Contact Invacare for more details.

**WARNING!****Risk of injury**

Safety restraint devices must only be used when the wheelchair user's weight is 22 kg or more.

- When the user weight is lower than 22 kg, do not use the wheelchair as a seat in a vehicle.



CAUTION!

There is a risk of injury if the mobility device is not properly secured during use as a vehicle seat.

- If possible, the user should always leave the mobility device to use a vehicle seat and the safety belts provided with the vehicle.
- The mobility device should always be tied down facing in the transport vehicle's intended direction of travel.
- The mobility device must always be secured in accordance with the mobility device and tie-down system manufacturers' user manual.
- Always remove and secure any accessory parts fixed to the mobility device such as chin controls or tables.
- If your mobility device is fitted with an angle adjustable backrest, then it must be placed in an upright position.
- Fully lower elevated legrests, if fitted.
- Fully lower the seat lifter, if fitted.



CAUTION!

Risk of injury exists if a mobility device that is not fitted with leak-proof batteries is transported in a vehicle.

- Only ever use leak-proof batteries.



CAUTION!

Risk of injury or damage to the mobility device or to the transporting vehicle, if the legrests are in a raised position while the mobility device is used as a vehicle seat.

- Always completely lower height-adjustable legrests, if fitted.



In order to use a mobility device as a motor vehicle seat, it needs to be fitted with attachment points to enable tie-down in the motor vehicle. These accessories may be included in the standard scope of mobility device order and delivery in some countries (UK for example), but may also be obtained from Invacare as an option in other countries.

This mobility device complies with the requirements of ISO 7176-19 and may be used as a vehicle seat in connection with a tie-down system that has been checked and approved in accordance with ISO 10542. The transporting vehicle must be professionally converted to tie down the mobility device. Contact your vehicle's manufacturer for more information.

The mobility device has undergone a crash test in which it was tied down in the transporting vehicle's direction of travel. Other configurations were not tested. The crash test dummy was secured using pelvic and upper body safety belts. Both types of safety belt should be used in order to minimize the risk of injuries to head or upper body.

It is imperative that the mobility device is inspected by an authorized dealer before being used again after being involved in a crash. Alterations to the mobility device

tie-down points may not be carried out without the manufacturer's permission.

9.3.1 How the mobility device is anchored in a vehicle

The mobility device is fitted with four tie-down points. Snap hooks or belt loops can be used for fixation. If the wheelchair can be used as a vehicle seat, these tie-down points are labelled with the symbol shown on the right.

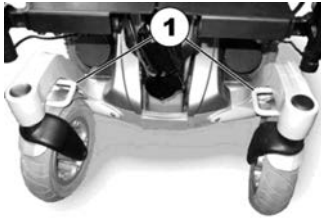

Fig. 9-1 Front

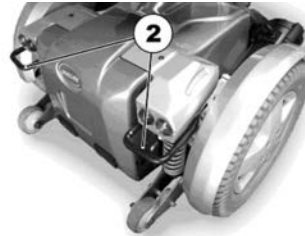

Fig. 9-2 Rear

1. Secure the mobility device at the front (1) and at the rear (2) with the tie-down system belts.
2. Secure the mobility device by tensioning the belts in accordance with the tie-down system manufacturer's user manual.

9.3.2 How the user is secured within the mobility device



CAUTION!

Risk of injury if the user is not properly secured within the mobility device

- Even if the mobility device is fitted with a posture belt, this is no substitute for a proper safety belt which complies with ISO 10542 in the transport vehicle. Always use the safety belt installed in the transport vehicle.
- Safety belts must be in contact with the user's body. They must not be held at a distance from the user's body using parts of the mobility device such as armrests or wheels.
- Safety belts must be pulled as tightly as possible without causing the user discomfort.
- Safety belts must not be positioned while twisted.
- Ensure that the third seat belt anchorage point is not fixed directly to the vehicle floor, but to one of the vehicle uprights.



CAUTION!

Risk of injury during use of the mobility device as a vehicle seat if a headrest is wrongly adjusted or not installed

This can cause the neck to be hyperextended during collisions.

- A headrest must be installed. The headrest optionally supplied for this mobility device by Invacare is perfectly suitable for use during transport.
- The headrest must be adjusted to the user's ear height.

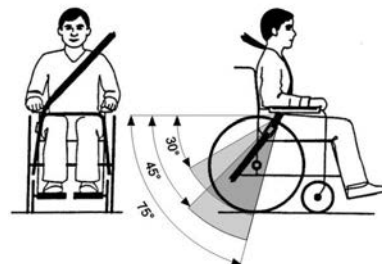

The pelvic belt should be positioned in the area between the user's pelvis and thighs so that it is unobstructed and not too loose. The ideal angle of the pelvic belt to the horizontal is between 45° and 75°. The maximum permissible angle is between 30° and 75°. The angle should never be less than 30°!

Seat belts may not be held at a distance from the user's body using parts of the mobility device such as armrests or wheels.

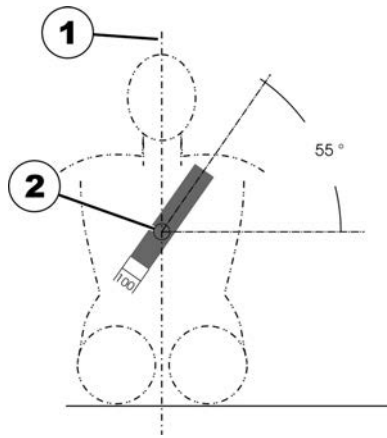

The safety belt installed in the transporting vehicle should be applied as shown in the illustration above.

- 1) Center line of the body
- 2) Center of the sternum

9.4 Transporting the mobility device without occupant



CAUTION! Risk of injury

– If you are unable to fasten your mobility device securely in a transport vehicle, Invacare recommends that you do not transport it.

Your mobility device may be transported without restrictions, whether by road, rail or by air. Individual transport companies have, however, guidelines which can possibly

1529686-S

restrict or forbid certain transport procedures. Please ask the transport company regarding each individual case.

- Before transporting your mobility device, make sure the motors are engaged and that the remote is switched off. Invacare strongly recommends that you additionally disconnect or remove the batteries. Refer to Removing the batteries.
- Invacare strongly recommends securing the mobility device to the floor of the transporting vehicle.

9.4.1 Opening the rear cover



Removing the rear cover

1. Loosen and remove the two knobs (1) on the left and right side of the rear casing.
2. Lift the rear cover carefully. The front part of the cover is held at the top by a Velcro strip. This must also be released.

Fitting the rear cover

1. Fit the parts in the reverse order.
2. Tighten the two knobs by hand.

9.4.2 Making the batteries accessible



WARNING!

Fire and burn hazard due to short circuit at battery poles

- DO NOT short-circuit the battery poles with a tool or metal parts of the wheelchair.
- Make sure that the battery pole caps are attached at all times when you are not working on the battery poles.



CAUTION!

Risk of crushing

The batteries are very heavy. There is a risk of hand injury.

- Be aware that the batteries are very heavy.
- Handle the batteries with care.



Be careful when handling small parts such as screws and washers during disassembly. Place the small parts down in a way that makes it easy to reassemble them in the correct order.

1. Remove the rear cover as described in chapter 9.4.1 *Opening the rear cover, page 103*
- 2.

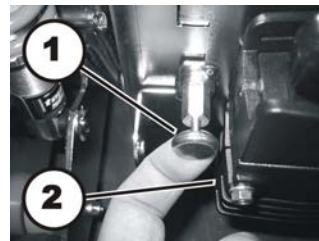

Pull the snap fitting (1) beside the power module backwards.

3. Lift the power module with the holder and remove the mounting from the battery cap flap.
4. Place the power module and the mounting on top of the battery compartment or actuator module, if applicable.

5.

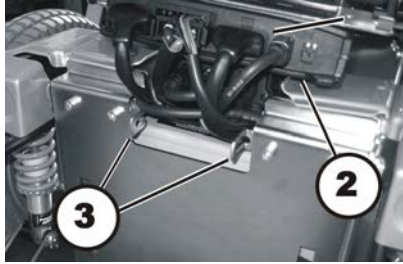

Press both locking mechanisms (3) in and open the battery flap.

6.

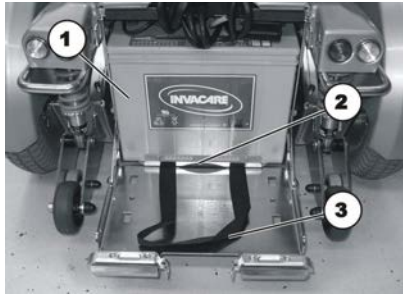

Use the strap (3) to pull the batteries (1) and the battery carrier (2) forward as far as possible.

9.4.3 Removing/Installing the batteries

This chapter applies for Storm4 Max only.



Tools:

- 11 mm socket spanner

Removing the batteries

1. Make the batteries accessible as described in chapter 9.4.2 *Making the batteries accessible*, page 104

2.

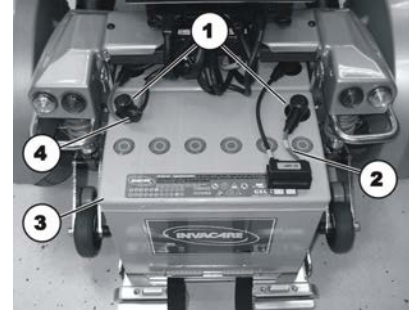

Remove the pole caps (1) from the accessible battery (3).

3. Remove the pole screws located under the pole caps using an 11-mm socket spanner.
4. Remove the connection cable (4) and the fuse cable (2).
5. Lift the battery from the battery carrier.
6. Pull the second battery forward using its strap.
7. Disconnect the cables of the second battery as well.
8. Lift the second battery from the battery carrier.

Fitting the batteries

1. Fit the batteries in the reverse order.
2. Ensure that the connectors and sockets in the battery compartment are fitted correctly. There is a polarity diagram in the rear cover.

10 Maintenance

10.1 Maintenance introduction

The term “Maintenance” means any task performed to ensure that a medical device is in good working order and ready for use as intended. Maintenance encompasses different areas, such as everyday care and cleaning, inspection checks, repair tasks and refurbishment.



Have your vehicle checked once a year by an authorized Invacare provider in order to maintain its driving safety and roadworthiness.

10.2 Cleaning the mobility device

When cleaning the mobility device, pay attention to the following points:

- Only use a damp cloth and gentle detergent.
- Do not use any abrasive or scouring agents.
- Do not subject the electronic components to any direct contact with water.

10.3.1 Before each use of the mobility device

Item	Inspection check	If inspection is not passed
Horn	Check of correct mode of operation.	Contact your provider.
Lighting unit	Check of correct operating mode for all lights such as indicators, headlights and rear lights.	Contact your provider.

- Do not use any high-pressure cleaning devices.

Disinfection

Spray or wipe disinfection using a tested and recognised product is permitted. A list of the current permitted disinfectants is available from the Robert Koch Institute at <http://www.rki.de>.

10.3 Inspection checks

The following table lists inspection checks that should be performed by the user and their intervals. If the mobility device fails to pass one of the inspection checks, refer to the chapter indicated or contact your authorized Invacare provider. A more comprehensive list of inspection checks and instructions for maintenance work can be found in the service manual for this device, which can be obtained from Invacare. That manual, however, is intended to be used by trained and authorized service technicians, and describes tasks which are not intended to be performed by the user.

Item	Inspection check	If inspection is not passed
Batteries	Check of battery charging status. Refer to remote manual for information about battery charging status display.	Charge batteries (see chapter 8.2.3 <i>How to charge the batteries, page 94</i>).
Foldable antitippers	Check whether antitippers are in driving position. Check whether locking pin is fully engaged.	Bring antitippers into driving position (see chapter 7.7 <i>Using foldable antitippers, page 88</i>). Make sure that locking pin engages.

10.3.2 Weekly

Item	Inspection check	If inspection is not passed
Armrests /side parts	Check that armrests are firmly attached in their holders and do not wobble.	Tighten the screw or clamping lever that holds the armrest (see chapter 5 <i>Setup, page 31</i>). Contact your provider.
Tires (pneumatic)	Check that the tires are undamaged.	Contact your provider.
	Check that the tires are inflated to the correct pressure.	Inflate the tire to the correct pressure (see chapter 12 <i>Technical data, page 112</i>). Contact your provider to have it repaired.
Tires (puncture-proof)	Check that the tires are undamaged.	Contact your provider.

10.3.3 Monthly

Item	Inspection check	If inspection is not passed
All upholstered parts	Check for damage and wear.	Contact your provider.
Removable legrests	Check whether the legrests can be fixed securely and whether the loosening mechanism is properly operable.	Contact your provider.
	Check that all adjustment options function properly.	Contact your provider.
Casters	Check that casters rotate and swivel freely.	Contact your provider.
Drive wheels	Check that the drive wheels rotate without wobbling. It is easiest to have someone stand behind the mobility device and observe the drive wheels as you drive away from them to do this.	Contact your provider.
Electronics and connectors	Check all cables for damage and all connecting plugs for snug fit.	Contact your provider.

10.4 Wheels and tires

Dealing with wheel damages

In case of having a damaged wheel, contact your provider. Because of safety reasons do not have the wheel repaired by yourself or by not authorized persons.

Dealing with pneumatic tires



Risk of damage to tire and rim

Never drive with too low tire pressure, this could result in damage to tire.

If tire pressure is exceeded rim could be damaged.

– Inflate tires to recommended pressure.



Use tire gauge to check pressure.

Check weekly that the tires are inflated to the correct pressure, see chapter *10.3 Inspection checks, page 106*

For recommended tire pressure see inscription on tire/rim or contact Invacare. Compare table below for conversion.

psi	bar
22	1.5
23	1.6
25	1.7

psi	bar
26	1.8
28	1.9
29	2.0
30	2.1
32	2.2
33	2.3
35	2.4
36	2.5
38	2.6
39	2.7
41	2.8
44	3.0

10.5 Short-term storage

In case a serious fault is detected, a number of safety mechanisms are built into your mobility device and will protect it. The power module prevents your mobility device from driving.

When the mobility device is in such a condition and while waiting for repair:

1. Switch off power.
2. Disconnect the batteries.
Depending on the mobility device model, you can either remove the battery packs or disconnect the batteries from the power module. Refer to the corresponding chapter about disconnecting the batteries.
3. Contact your provider.

10.6 Long-term storage

In case your mobility device is not used for a longer period of time, you need to prepare it for storage to ensure a longer life for your mobility device and batteries.

Storing mobility device and batteries

- We recommend to store the mobility device at a temperature of 15° C, avoid hot and cold extremes when storing to ensure a long service life of the product and batteries.
- The components are tested and approved for greater temperature ranges as detailed below:
 - Allowable temperature range to store the mobility device is -40° up to 65° C.
 - Allowable temperature range to store batteries is -25° up to 65° C.
- Even not being used, batteries discharge themselves. Best practice is to disconnect the battery supply from the power module if storing the mobility device longer than two weeks. Depending on the mobility device model, you can either remove the battery packs or disconnect the batteries from the power module. Refer to the corresponding chapter about disconnecting the batteries. If in doubt which cable to disconnect, contact your provider.

- Batteries should always be fully charged before storing.
- If storing the mobility device longer than four weeks, check the batteries once a month and recharge as needed (before gauge reads half full) to avoid damage.
- Store in a dry, well-ventilated environment protected from outer influences.
- Slightly overinflate pneumatic tires.
- Position the mobility device on flooring that is not discolored by contact with tire rubber.

Preparing mobility device for use

- Re-connect the battery supply to the power module.
- The batteries must be charged before use.
- Have the mobility device checked by an authorized Invacare provider.

10.7 Disconnect the power module

1.



Remove the rear cover, refer to 9.4.1 *Opening the rear cover, page 103*

2.

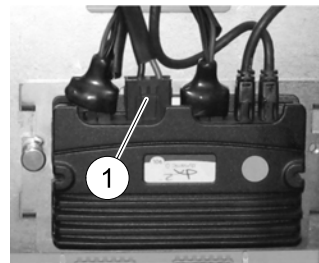

Remove the battery cable (1) from the power module.

11 After Use

11.1 Reconditioning

The product is suitable for reuse. To recondition the product for a new user, carry out the following actions:

- Cleaning and disinfection. Refer to *10 Maintenance, page 106*
- Inspection according to service plan. Consult service instructions, available from Invacare.
- Adaptation to the user. Refer to *5 Setup, page 31*.

11.2 Disposal

- The equipment wrapping is potentially recyclable.
- The metal parts are used for scrap metal recycling.
- The plastic parts are used for plastic recycling.
- Electric components and printed circuit boards are disposed of as electronic scrap.
- Exhausted or damaged batteries can be returned to your medical equipment supplier or Invacare.
- Disposal must be carried out in accordance with the respective national legal provisions.
- Ask your city or district council for details of the local waste management companies.

12 Technical data

12.1 Technical specifications

The technical information provided hereafter applies to a standard configuration or represents maximum achievable values. These can change if accessories are added. The precise changes to these values are detailed in the sections for the respective accessories.

 Note that in some cases the measured values may vary up to ± 10 mm.

Permissible operating and storage conditions	
Temperature range for operation according to ISO 7176-9:	<ul style="list-style-type: none"> -25° ... +50 °C
Recommended storage temperature:	<ul style="list-style-type: none"> 15 °C
Temperature range for storage according to ISO 7176-9:	<ul style="list-style-type: none"> -25° ... +65 °C with batteries -40° ... +65 °C without batteries

Electrical system	
Motors	<ul style="list-style-type: none"> 340 W (conventional motors) 600 W (True Track® Plus motors)
Batteries	<ul style="list-style-type: none"> 2 x 12 V/73.5 Ah (C20) leakproof/gel
Main fuse	<ul style="list-style-type: none"> 80 A
Degree of protection	IPX4 ¹

Charging device	
Output current	<ul style="list-style-type: none"> 8 A \pm 8 % 10 A
Output voltage	<ul style="list-style-type: none"> 24 V nominal (12 cells)

Drive wheel tires		
Tire type	<ul style="list-style-type: none"> • 3.00 - 8" pneumatic, puncture-protected or puncture-proof 	<ul style="list-style-type: none"> • Trelleborg 8x3.00 pneumatic or puncture-protected
Tire pressure	<p>The recommended maximum tire pressure in bar or kpa is marked on the side wall of the tire or the rim. If more than one value is listed, the lower one in the corresponding units applies.</p> <p>(Tolerance = -0.3 bar, 1 bar = 100 kpa)</p>	

Caster tires		
Tire type	<ul style="list-style-type: none"> • 3.00 - 6 pneumatic, puncture-protected or puncture-proof 	
Tire pressure	<p>The recommended maximum tire pressure in bar or kpa is marked on the side wall of the tire or the rim. If more than one value is listed, the lower one in the corresponding units applies.</p> <p>(Tolerance = -0.3 bar, 1 bar = 100 kpa)</p>	

Driving characteristics		
Speed	<ul style="list-style-type: none"> • 6 km/h • 10 km/h • 13 km/h 	
Min. braking distance	<ul style="list-style-type: none"> • 1000 mm (6 km/h) • 2100 mm (10 km/h) • 3400 mm (13 km/h) 	
Rated slope ² :		
	without lifter	<ul style="list-style-type: none"> • 11.3° (20 %) according to manufacturer's specifications with 150 kg payload, 4° seat angle, 20° backrest angle
	with lifter	<ul style="list-style-type: none"> • 8° (15 %) according to manufacturer's specifications with 150 kg payload, 4° seat angle, 20° backrest angle

Driving characteristics	
Max. climbable obstacle height	<ul style="list-style-type: none"> • 100 mm (with curb climber) • 60 mm (without curb climber)
Turning diameter	<ul style="list-style-type: none"> • 1770 mm
Turning width	<ul style="list-style-type: none"> • 1100 mm
Pivot width	<ul style="list-style-type: none"> • 1500 mm
Drive range in accordance with ISO 7176-4 ³	<ul style="list-style-type: none"> • 36 km (Storm 4) • 42 km (Storm 4 X-plore) • 59 km (Storm 4 True Track)

Dimensions in accordance with ISO 7176-15	Seat type	
	Standard	Easy-Adapt
Total height	<ul style="list-style-type: none"> • 970 mm 	<ul style="list-style-type: none"> • 1050 mm
Total width	<ul style="list-style-type: none"> • 630 - 770 mm 	
Total length (incl. standard legrests)	<ul style="list-style-type: none"> • 1190 mm 	
Total length (without standard legrests)	<ul style="list-style-type: none"> • 910 mm 	
Stowage length	<ul style="list-style-type: none"> • 1025 mm 	<ul style="list-style-type: none"> • 915 mm
Stowage width	<ul style="list-style-type: none"> • 650 mm 	<ul style="list-style-type: none"> • 640 mm
Stowage height	<ul style="list-style-type: none"> • 1040 mm 	<ul style="list-style-type: none"> • 1085 mm
Ground clearance	<ul style="list-style-type: none"> • 60 mm 	
Seat height ⁴ (with lifter)	<ul style="list-style-type: none"> • 400 - 650 mm (Storm 4) • 440 - 690 mm (Storm 4 X-plore) 	

Dimensions in accordance with ISO 7176-15	Seat type	
	Standard	Easy-Adapt
Seat height ⁴ (without lifter)	• 450/480 mm	
Seat width	• 380 - 530 mm	
Seat depth	• 380 - 530 mm	
Backrest height ⁴	• 480/540 mm	• 650 mm
Backrest angle	• 80°, 90°, 97,5°, 105°, 112,5°, 120° (man.)	• 85°...125°
Armrest height	• 250-340/290-380 mm	
Armrest depth ⁵	• 325 mm	
Horizontal location of axle ⁶	• 115 mm	• 100 mm
Legrest length	• 290 - 460 mm	
Legrest angle	• 0° ... 75°	
Seat angle, electrical adjustment	• 0° - 25°	
Seat angle, manual adjustment	• 0° - 9°	

Dimensions in accordance with ISO 7176-15	Seat type		
	RECARO	Optimist	Modulite
Total height	<ul style="list-style-type: none"> • 970 mm 	<ul style="list-style-type: none"> • ca. 970 mm⁷ 	<ul style="list-style-type: none"> • 1020 mm (one piece seat plate) • 1090 - 1190 mm (telescopic seat frame, moving the backrest plate)
Total width	<ul style="list-style-type: none"> • 630 - 770 mm 		
Total length (incl. standard legrests)	<ul style="list-style-type: none"> • 1190 mm 	<ul style="list-style-type: none"> • ca. 1190 mm⁷ 	<ul style="list-style-type: none"> • 1190 mm
Total length (without standard legrests)	<ul style="list-style-type: none"> • 910 mm 	<ul style="list-style-type: none"> • ca. 910 mm⁷ 	<ul style="list-style-type: none"> • 910 mm
Stowage length	<ul style="list-style-type: none"> • 935 mm 	<ul style="list-style-type: none"> • see manufacturer's data⁷ 	<ul style="list-style-type: none"> • 980 mm
Stowage width	<ul style="list-style-type: none"> • 725 mm 		<ul style="list-style-type: none"> • 705 mm
Stowage height	<ul style="list-style-type: none"> • 960 mm 		<ul style="list-style-type: none"> • 1130 mm
Ground clearance	<ul style="list-style-type: none"> • 65 mm 		<ul style="list-style-type: none"> • 65 mm
Seat height ⁴ (with lifter)	<ul style="list-style-type: none"> • 400 - 650 mm (Storm 4) • 440 - 690 mm (Storm 4 X-plore) 		
Seat height ⁴ (without lifter)	<ul style="list-style-type: none"> • 450/480 mm 		
Seat width	<ul style="list-style-type: none"> • 490 - 530 mm 	<ul style="list-style-type: none"> • see manufacturer's data⁷ 	<ul style="list-style-type: none"> • 380 mm (380 - 430 mm) • 430 mm (430 - 480 mm) • 480 mm (480 - 530 mm) • 530 mm (530 - 580 mm)
Seat depth	<ul style="list-style-type: none"> • 460 - 510 mm 		<ul style="list-style-type: none"> • 410 - 510 mm

Dimensions in accordance with ISO 7176-15	Seat type		
	RECARO	Optimist	Modulite
Backrest height ⁴	<ul style="list-style-type: none"> 770 - 830 mm 		<ul style="list-style-type: none"> 480/540 mm (sling back) 560 - 660 mm (telescopic seat frame, moving the backrest plate)
Backrest angle	<ul style="list-style-type: none"> 90° ... 135° 		<ul style="list-style-type: none"> 90° ... 120°
Armrest height	<ul style="list-style-type: none"> 250-340/290-380 mm 		<p>Telescopic seat frame:</p> <ul style="list-style-type: none"> 245 - 310/295 - 360 mm (T-armrest) 230 - 360 mm (flip-up armrest) 230 - 300/300 - 360 mm (following armrest) <p>One piece seat plate:</p> <ul style="list-style-type: none"> 275 - 340/325 - 390 mm (T-armrest)
Armrest depth ⁵	<ul style="list-style-type: none"> 325 mm 		<ul style="list-style-type: none"> 398 mm
Horizontal location of axle ⁶	<ul style="list-style-type: none"> 145 mm 		<ul style="list-style-type: none"> 150 mm
Legrest length	<ul style="list-style-type: none"> 290 - 460 mm 		<ul style="list-style-type: none"> 290 - 460 mm
Legrest angle	<ul style="list-style-type: none"> 0° ... 75° 		<ul style="list-style-type: none"> 0° ... 75°
Seat angle, electrical adjustment	<ul style="list-style-type: none"> 0° - 25° 		
Seat angle, manual adjustment	<ul style="list-style-type: none"> 0° - 9° 		

Weight	
Curb weight ⁸	<ul style="list-style-type: none"> at least 174 kg
Component weights	
Batteries	<ul style="list-style-type: none"> approx. 24.5 kg per battery
Payload	
Max. payload	<ul style="list-style-type: none"> 150 kg
Axle loads	
Max. front axle load	<ul style="list-style-type: none"> 200 kg
Max. rear axle load	<ul style="list-style-type: none"> 300 kg

- 1 IPX4 classification means that the electrical system is protected against spray water.
- 2 Static stability according to ISO 7176-1 = 9° (15.8 %)
Dynamic stability according to ISO 7176-2 = 6° (10.5 %)
- 3 Note: The drive range of a mobility device is strongly influenced by external factors, such as the speed setting of the wheelchair, the charging state of the batteries, surrounding temperature, local topography, road surface characteristics, tire pressure, weight of user, drive style and use of batteries for lighting, servos etc.

The specified values are theoretical maximum achievable values measured according to ISO 7176-4.
- 4 Measured without seat cushion
- 5 Distance between backrest reference plane and most forward part of armrest assembly
- 6 Horizontal distance of wheel axle from intersection of loaded seat and backrest reference planes

- 7 Dependent on the seat dimensions. See the manufacturer's data on www.ajstole.dk
- 8 The actual curb weight depends on the fittings your mobility device has been supplied with. Every Invacare mobility device is weighed when leaving the works. Refer to the nameplate for the curb weight (including batteries) measured.

13 Service

13.1 Inspections performed

It is confirmed by stamp and signature that all jobs listed in the inspection schedule of the service and repair instructions have been properly performed. The list of the inspection jobs to be performed can be found in the service manual which is available through Invacare.

Delivery Inspection	1st Annual Inspection
Stamp of authorized provider / Date / Signature	Stamp of authorized provider / Date / Signature
2nd Annual Inspection	3rd Annual Inspection

Stamp of authorized provider / Date / Signature	Stamp of authorized provider / Date / Signature
4th Annual Inspection	5th Annual Inspection
Stamp of authorized provider / Date / Signature	Stamp of authorized provider / Date / Signature

Invacare Sales Companies

Australia:

Invacare Australia PTY. Ltd.
1 Lenton Place, North Rocks NSW
2151

Australia

Phone: 1800 460 460

Fax: 1800 814 367

orders@invacare.com.au

www.invacare.com.au

United Kingdom:

Invacare Limited

Pencoed Technology Park, Pencoed

Bridgend CF35 5AQ

Tel: (44) (0) 1656 776 222

Fax: (44) (0) 1656 776 220

uk@invacare.com

www.invacare.co.uk

Canada:

Invacare Canada LP
570 Matheson Blvd E. Unit 8
Mississauga Ontario

L4Z 4G4, Canada

Phone: (905) 890 8300

Fax: (905) 501 4336

Eastern Europe, Middle East & CIS:

Invacare EU Export

Kleiststraße 49

D-32457 Porta Westfalica / Germany

Tel: (49) (0)57 31 754 540

Fax: (49) (0)57 31 754 541

webinfo-eu-export@invacare.com

www.invacare-eu-export.com

Ireland:

Invacare Ireland Ltd,
Unit 5 Seatown Business Campus
Seatown Road, Swords, County Dublin

Tel : (353) 1 810 7084

Fax: (353) 1 810 7085

ireland@invacare.com

www.invacare.ie

New Zealand:

Invacare New Zealand Ltd
4 Westfield Place, Mt Wellington 1060
New Zealand

Phone: 0800 468 222

Fax: 0800 807 788

sales@invacare.co.nz

www.invacare.co.nz



Manufacturer:

Invacare Deutschland GmbH

Kleiststraße 49

D-32457 Porta Westfalica

Germany

1529686-S 2017-07-03



Making Life's Experiences Possible®



Yes, you can.®