

# TGA *Powerpack*



Operating Instructions and Owner's Handbook



<b>Contents</b>	<b>Page</b>
Introduction	3
Components of your Powerpack	4
General Instructions	4
Fitting Instructions	6
Additional Fitting Hints	10
Controls	11
Using the Powerpack	12
Batteries	13
Battery Charging	14
Transportation	15
Warranty	16

## 1. Introduction

**The TGA Wheelchair Powerpack** – Your New Mark 5 TGA Wheelchair Powerpack encompasses all of the tried and tested technology of the previous versions along with some exciting new developments. Over years of development TGA has designed a wide range of fitting kits to ensure the Powerpack fits almost any wheelchair in seconds. Once fitted the Powerpack ensures you will never push your wheelchair as much again. Its customer friendly fitting & removal system means it can be easily removed for transit and refitted with ease.

This handbook provides important information on the most common operational and maintenance concerns that you should be familiar with when owning a Powerpack. It is very important that you are familiar with the controls and features of the Powerpack before its first use. The handbook will draw your attention to important safety related issues by **Care! Warning** labeling. Please keep this handbook for future referral.

### **Care! Warning**

- Do not operate your Powerpack without fully reading and understanding this instruction manual first.
- Do not carry passengers or exceed the maximum carrying weight (see Technical Specifications).
- On wheelchairs with seats that can be adjusted into a reclining position, (Tilt in Space), always ensure that the lowest part of the seat is not touching any part of the Powerpack or its battery with the wheelchair user seated.
- Always ensure that there is nothing resting on the Powerpack or its battery pack.
- Do not switch your Powerpack on with the control lever depressed.
- Do not operate your Powerpack when under the influence of alcohol or certain drugs, which may impair your safety.
- Do not climb or descend curbs that exceed the Powerpack's capability.
- Do not turn when negotiating curbs. Always approach curbs at low speed and straight.
- Always stop fully before changing direction (forward or reverse).
- Always proceed carefully while operating your Powerpack, especially as you approach the gradient of a ramp or hill.
- Always proceed carefully whilst going over uneven surfaces.
- Do not operate your Powerpack through deep water or clean with a high pressure hose.

### **Intended Purpose**

Your Powerpack is intended for indoor and outdoor use by the attendant of a wheelchair. It can also be removed and disassembled to fit easily into the boot of a car.

## 2. Components of Your Powerpack

Your Powerpack will consist of the following components:

- Powerpack
- Wheelchair Mounting Brackets
- Hand Control
- Handlebar Grips or Alternate Mount Bracket
- Battery in Bag
- T Bar 5mm Allen Key
- 6mm Allen Key
- 2 x Ignition Keys

### General Instructions

1. These instructions apply to all four models of Wheelchair Powerpack. The Solo and Duo models are suitable for use when the wheelchair occupant weight up to 18 stones/114kg. The Heavy Duty model is suitable for use when the occupant weighs up to 26 stones/165kg and the Plus model has a 32 stones/203kg max user weight.
2. The standard Powerpack complete with battery weighs 13.1 kg (28.8 lbs), twin wheel version 14.5 kg (31.9 lbs), the heavy duty 16.05 kg (35.3 lbs) and the plus weighs 18kg (40lbs). Please refer to the wheelchair manufacturer's handbook for the maximum user weight limits of the wheelchair.
3. Please read these instructions very carefully before unpacking the Powerpack or attempting to fit it on a wheelchair.
4. As the Powerpack and its associated components are relatively heavy and fitted at a low level, great care must be taken not to strain when lifting and assembling on to wheelchairs.
5. Remove Powerpack from box first, then remove battery. Do not remove both together in case the battery slips causing damage or personal injury.
6. Check to ensure you have all contents as listed below (Fig 1):
  - Powerpack with lifting strap
  - Battery in bag complete with leads
  - Battery Charger
  - Crossbar
  - 2 Mounting brackets, left and right hand
  - Right hand handgrip with control
  - Left hand handgrip
  - Allen key "T bar" 5mm
  - Allen key 6mm
  - 2 keys
  - User manual
  - Warranty card



Fig 1 Powerpack Components

7. Always fit Powerpack to wheelchair first and then fit battery.
- **Care! Warning.** Always ensure there is an air gap between the Powerpack battery and the seat base with the user seated.
8. Always remove battery from Powerpack before disassembling from wheelchair.
9. Always ensure the on/off key is in the off position when connecting or disconnecting the battery.
10. Always ensure the on/off key is in the off position before anyone sits in or alights from the wheelchair.
11. Never operate the Powerpack without the chair being occupied.
12. The Powerpack is very simple to install and use. However, if you have any problems regarding fitting and use, please seek advice from a competent engineer or TGA.
13. Refer to section “Using the Wheelchair Powerpack” and the wheelchair manufacturers’ instructions (wheelchair handbook) before using the Powerpack for the first time.
14. Once fitted correctly to the wheelchair the Powerpack will make life a lot easier and take all the effort out of pushing a wheelchair. Not only will it make pushing uphill easier, but along the flat as well. Use it all of the time to power the chair or just when the going gets tough.

The Powerpack is very capable of powering up gentle hills without assistance and steeper hills can be climbed with assistance from the attendant. However, depending on the weight of the occupant and gradient of the hill, some hills may be too much for the Powerpack to cope with. The Powerpack has various built in protection circuits to stop serious damage to the motor and the electronics if for whatever reason an overload occurs. At this point the motor will shut down and you will have to switch the key off, wait a few seconds and switch back on to clear. However, in order to carry on climbing the gradient, a lot more effort will have to be put into pushing in order to assist the Powerpack and stop it shutting down again. If the Powerpack does shut down more than once, we would strongly recommend that you find an alternative route as the Powerpack will be trying to work outside its design limitations and continual use may cause damage.

15. The Powerpack is not designed to climb steep gradients, nor to take you anywhere under power assistance that you would not normally be able to push the chair without using any power assistance. It must be remembered that even if the chair can be powered uphill, you still have to get down the other side which can sometimes be even more difficult. We strongly recommend the fitting of attendant controlled brakes to your wheelchair if moderately steep or long slopes are likely to be negotiated, the wheelchair user is heavy or there are steep pavement cambers to negotiate.

16. Your batteries will need to be cycled (charged and discharged) between 10 and 15 times before they will give their maximum performance and range (See battery charging). Range is also dependent on various other factors, such as weight of occupant, number of hills and the gradient of hills encountered on your journey. In addition, how much assistance the attendant gives to push the wheelchair will affect the range. We strongly recommend that initially, journey distances are relatively short and are gradually increased. This will allow the opportunity to become used to the controls and take account of the improving performance of the battery.

**Note – The Powerpack should not be used on gradients greater than the maximum stated by the wheelchair manufacturer.**

### Fitting Instructions

1. Remove the Powerpack and all associated components from the packaging (Fig 1).
2. Both time and care must be taken to ensure the Powerpack is set up in accordance with these instructions and fitted in the position that best suits the particular chair it is being fitted to, both for ease of use and safety.
3. Ideally the Powerpack should be positioned so that the centre of the drive wheel/s runs approximately in line with the centre of the wheelchair rear wheels, Fig 2 A-A (Single and twin wheel models). This is not possible on some chairs, so it may have to be positioned more towards the rear but be aware that the further towards the rear it is fitted, the greater chance of it causing discomfort to the attendant whilst walking. Fit it as far forward as possible, but never fit forward of the wheelchair rear wheels. The drive wheel/s should always be set to run in the centre of the wheelchair (Fig 2 B-B). Twin wheel models should have a wheel running equal distance either side of the centre line of the wheelchair (Fig 2 B-B).

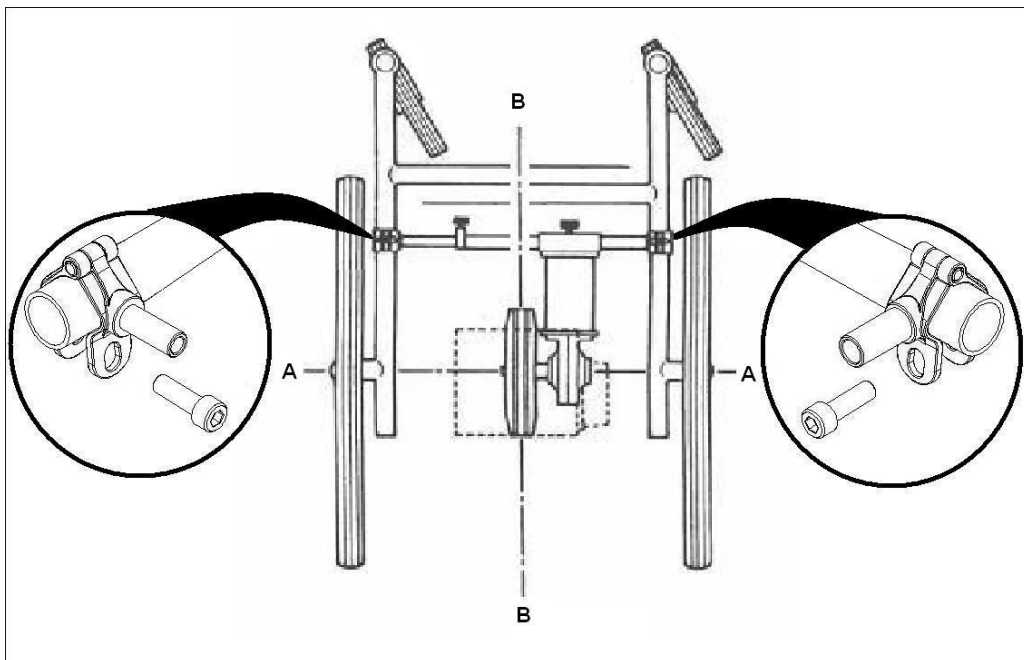

**Fig 2 Powerpack Fitting and Bracket Location Diagram**

4. Take the two mounting brackets and you will see that one has a larger diameter shaft than the other (Fig 3 C & D). Fit the larger diameter right hand mounting bracket to the bottom of the wheelchair frame on the right hand side, as viewed from the rear of the chair. Fit the smaller diameter left hand bracket in a corresponding position on the left hand side of the chair. Fig 2 demonstrates the approximate positioning of the mounting brackets on the chair (when viewed from above). Do not tighten at this stage.

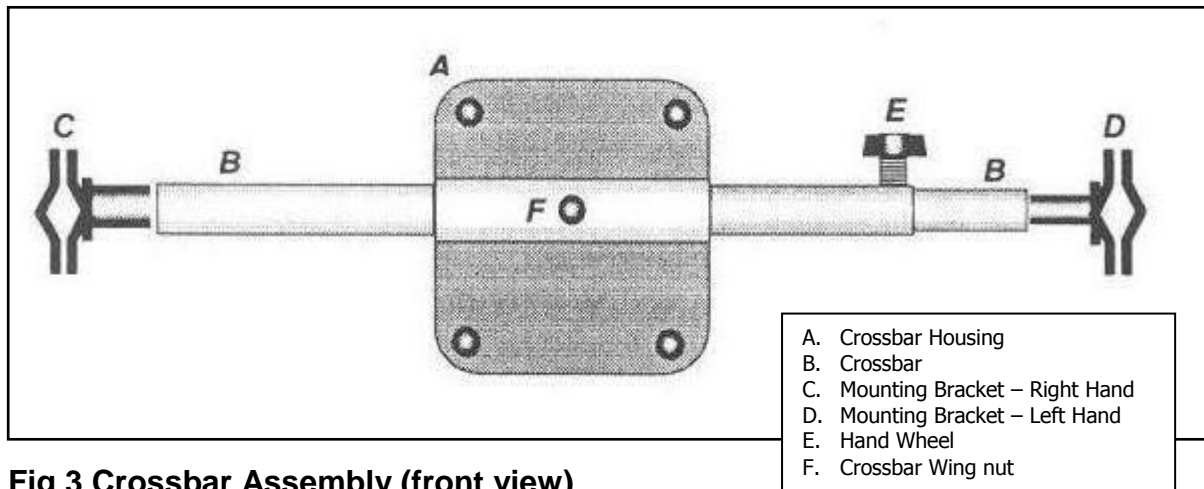

**Fig 3 Crossbar Assembly (front view)**

5. Take the two crossbar tubes. Insert the smaller diameter tube into the larger diameter tube at the hand wheel end (Fig 3E). Fit the larger diameter tube over the right hand mounting bracket (Fig 3C). Now compress the smaller diameter tube against the spring and offer it up to the left hand mounting bracket. Allow the spring to extend the tube over the bracket. Please note that the crossbar on the Heavy Duty model is not spring loaded, only the standard model has a spring loaded crossbar. Take care when using the crossbar as it is spring loaded and could cause damage or injury if not used correctly. Avoid over tensioning the spring by pushing the inner tube in more than necessary. Avoid pointing at anyone. Take care when fitting. Please note: On some heavy duty and some specialist wheelchairs it may be found that the crossbar is a little too long. Please consult your dealer or TGA.
6. Ensure the wheelchair is fully open (see wheelchair manufacturer's handbook). Adjust the position of the clamps so that they are directly opposite each other and the crossbar is at right angles to the wheelchair frame. Now lightly tighten the clamp retaining bolts with the allen key provided.
7. Compress the crossbar and remove from the wheelchair. Now hold the Powerpack so that the wheel is making contact with the ground and the crossbar housing is pointing away from you. Keeping the crossbar hand wheel to the left, insert the crossbar into the crossbar housing tube at the front of the motor.

8. Ensure wheelchair brakes are on and fit the Powerpack complete with crossbar on to the wheelchair by holding it in position and placing the right hand end of the crossbar over the mounting bracket (Fig 4). Allow the spring to extend the left hand tube over the other mounting bracket and lightly tighten the hand wheel (Fig 3E). To avoid damaging the crossbar, do not over tighten. The crossbar must always be fully extended against the mounting brackets to ensure safe attachment to the wheelchair frame. The wheelchair should always be fully extended prior to attaching the Powerpack and once the chair has been sat in, ensure that it has not expanded further and that the crossbar remains fully extended against the mounting brackets.

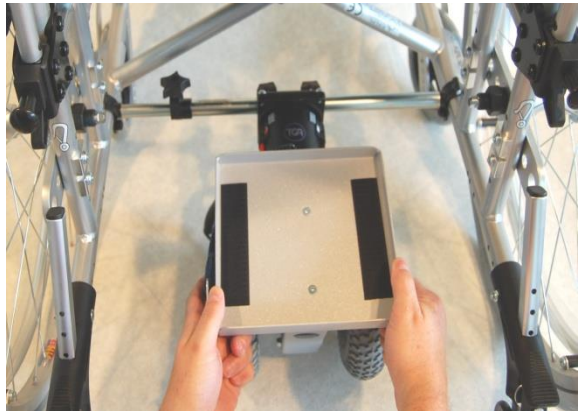

**Fig 4 Attaching Crossbar**

9. Check the alignment with the rear wheels and centre line of the wheelchair (see paragraph 3). Now firmly tighten the clamp bolts on the crossbar mounting brackets. Next ensure the crossbar is firmly against the mounting bracket shoulders and then tighten the crossbar hand wheel taking care not to damage the crossbar by over tightening. The drive wheel or wheels can be centralized between the wheelchair wheels by sliding the motor assembly along the crossbar. After centralising, tighten the crossbar wing nut (Fig 3F). Again, take care not to over tighten.
8. When using the Powerpack for the first time, if the wheelchair pulls to the left or right it is usually because the drive wheel or wheels are not central. To remedy this, simply adjust the Powerpack on the crossbar as in Paragraph 9 until the wheelchair pulls in a straight line. Similarly, if the mounting brackets have not been fitted directly opposite each other, this will also cause the wheelchair to pull to one side or the other.
9. Place the battery in the tray with the writing on the bag uppermost and the handle towards you. The battery bag is securely held in place by Velcro (Fig 7).



**Fig 7 Fitting and Connecting Battery**



10. The next item to fit is the handlebar control (Fig 5). This unit performs many functions in addition to controlling the motor.

11. The handlebar control can be fitted to either the Alternative Mount Bracket, which fits to the standard wheelchair handle bar, in front of the handgrip, or it can be fitted to the extended handlebar grips supplied by TGA as an additional kit.

12. If fitting the extended handlebar grips, they replace the original wheelchair handlebar grips as well as providing extension handlebars for added comfort when controlling the chair. If the handlebar control is received fitted to the extension, it is usually set for right hand use but can be reset for left hand operation.

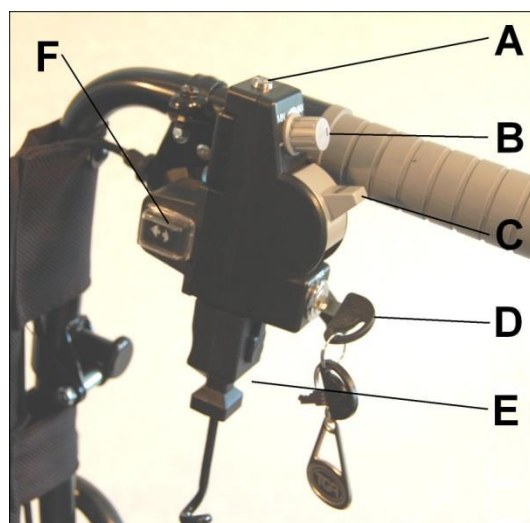

Fig 5

13. To fit the extended handlebar grips, remove both handlebar grips from your wheelchair. These are probably glued on, so the best way of removal is to carefully cut the grip down one side with a sharp knife and peel off. Taking each new handlebar grip in turn, remove the rubber end caps and engage the long 4mm allen key T bar into the expander bolt located approximately half way down the inside of the new handlebar grip. Looking in the other end of the handlebar grip, you will see an expanding bolt, which is the retainer for locking the new handlebar grip onto the wheelchair handlebar. With the allen key T bar, unscrew the expander bolt so that the 4 expanding arms are unexpanded and flush with the internal barrel (until approximately a quarter of the bolt thread is left in the internal barrel). You may need to hold your finger on the barrel while this is taking place to prevent it turning. Keep the allen key T bar located in the expander bolt, as this makes fitting easier and now slide the new grip fitted with the control onto the right hand wheelchair handlebar (Fig 5). The new grips are obviously longer than the ones removed and this enables the original handlebars to be extended. This is sometimes useful when fitting the Powerpack to give more clearance for your feet. Now tighten the expander bolt as much as you can using the long allen key T bar (Fig 6). The control unit should now be in a vertical location (Fig 6). Repeat for the other handlebar grip. NB To ensure a positive fitting, at least 7.5 cm (3 inches) of the wheelchair handlebar must be covered by the new grip.

**Care! Warning** The correct fitting of the new handlebar grips and control unit is essential to the control of the wheelchair and safety of the occupant. Please read these fitting instructions very carefully and if you are in any doubt or require any assistance please contact your dealer or TGA.

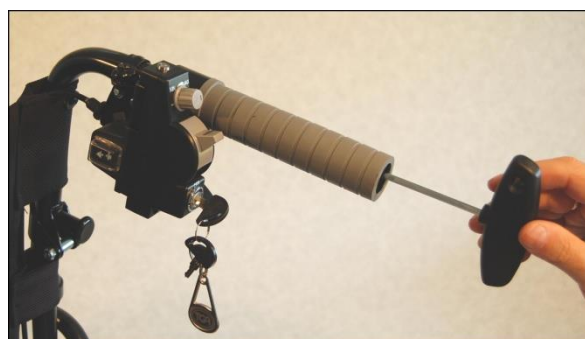

Fig 6

14. If you require the wheelchair to be operated from the left hand side simply remove the backing plate at the top of the handlebar, under the plate are two bolts which hold the control to the handlebar grip. Remove the control and re-fit to the left hand grip with the allen key T bar provided.
15. Connect the plug into the socket at the base of the handlebar control. Ensure that it connects positively (Fig 5E).
16. Connect the battery plug and socket to the plug and socket from the controller. This can only be done one way, red to red and black to black (Fig 7).
17. Take the loop at the top of the lifting strap and place it over the left handlebar of the wheelchair. You will note a two piece buckle in the strap. When the two parts of the buckle are fastened in the closed position it will create a loop in the strap. Make sure the buckle is open and that the strap is just a straight length. Now take the strap adjuster and alter as necessary the length of the strap by pulling it through the adjuster until the wheel of the Powerpack sits firmly on the ground and the strap is just slack. Allow enough slack so that the Powerpack has approximately one inch of downward movement, sufficient to cope with rough terrain or potholes. To lift the Powerpack wheel clear of the ground, simply raise the Powerpack by pulling up the strap below the buckle. Now fasten the two parts of the buckle together and this will hold the Powerpack securely off the ground. To lower the Powerpack on to the ground, support the unit by holding the lower part of the strap, release the buckle and gently lower the Powerpack. Always ensure that the strap does not foul any moving components and that it is always attached to the handlebar; particularly make sure that the strap doesn't foul on any attendant brake levers.

### **Additional Fitting Hints**

1. The Powerpack is normally fitted between the two horizontal tubes of the wheelchair frame. If this is not possible, it can be fitted between vertical or diagonal tubes.
2. The angle that the Powerpack is mounted at is important in terms of performance. To check that the Powerpack is mounted at the correct angle, measure from the bottom of the crossbar housing to the ground (to do this the Powerpack should be fitted to the wheelchair and on even terrain). Ideally, this distance should be between 12.5 to 16.5 cm (5 to 6.5 inches approximately). If this distance is less than 12.5 cm, the front of the Powerpack is too low. This is most likely to occur on wheelchairs with very small wheels or a particularly low frame. If the distance is greater than 16.5 cm, the front of the Powerpack is too high. In either case, TGA have a range of adaptations to facilitate the optimum positioning of the Powerpack on your wheelchair. The above is only a guide and the distances are approximations. If you are in any doubt, please contact TGA.

## Controls

1. **ON/OFF LIGHT & BATTERY CONDITION INDICATOR** - At the top of the handlebar control you will see a light (Fig 5A). This is a multi-function light and will come on when the ON/OFF key (Fig 5D) is switched to on indicating the machine is ready for use. In addition it has another function which is to indicate the state of charge of the battery. When you switch on you will notice the light go through a sequence of colours, starting at red through amber to green, indicating the battery is fully charged. Providing the battery is fully charged the green will stay on until the battery charge condition drops to a level that will change the light to amber, indicating that the battery should soon be recharged. At the final stage of the light sequence the amber will change to red indicating the battery has a very low charge and should be recharged at the very earliest opportunity. The third function of the light is to provide a fault code indication. This will operate if the Powerpack has a fault or is overloaded. The machine will cutout and the light will flash a certain sequence. To reset, switch off, wait a few seconds and switch on again. If the fault has not cleared, contact your dealer or TGA. On the Powerpack Plus, the battery indicator light will stay on when low voltage is detected, to clear turn off wait a few seconds and restart.
2. **PRESET SPEED CONTROL** - Immediately under the light is a small round control which is the Preset Speed Control (Fig 5B). This will control the maximum speed of the Powerpack by turning in a clockwise direction to increase speed and anticlockwise to reduce speed, particularly useful when going around shops or other confined spaces where a high level of control is needed.
3. **SPEED CONTROL LEVER** - Whilst the Preset Speed Control will limit the top speed of the Powerpack, the speed control lever will progressively control the speed up to the preset limit (Fig 5C). The more you push the lever down with your thumb the quicker you will go. An alternative use for the lever is to preset your top speed with the preset control, then use the lever as a button simply by pressing from top to bottom in one movement. The electronics will still provide a smooth take off.
4. **ON/OFF KEY** - Situated under the speed lever this is simply an ON/OFF switch with removable key (Fig 5D). The key will be in a vertical position for off. Turn clockwise for on. Never leave switched on when not in use or with someone sitting in an unattended chair. When leaving the chair always take the key with you.
5. **DIRECTION SWITCH** - Fitted on the left hand side of the hand control on powerpacks with the reverse upgrade. (Fig 5F). The direction switch controls the direction that the powerpack will operate (forward and reverse). With the ignition key switched off simply press the direction switch forward to operate the powerpack forward, and in the reverse position to operate the powerpack backwards. Please note: if using the hand control on the left hand handlebar the direction switch can be removed and rotated so that it is facing inwards.

## Using the Wheelchair Powerpack

1. Set the Preset Speed Control to approximately half speed for your initial tests. Turn the key to on and then by using gentle pressure on the speed control lever, the wheelchair will move in a forward direction (on powerpacks fitted with reverse the powerpack will travel in the direction selected by the direction switch). The more pressure on the lever, the quicker the wheelchair will move. Never operate the Wheelchair Powerpack without the wheelchair being occupied.
2. Now release the lever and the wheelchair will roll gently to a stop. Try this process a few times to practice stopping and starting. Now practice at slightly higher speeds and for longer periods until you feel confident with the controls.
3. Remember that both the speed control lever and the Preset Speed Control are also power controls and as the terrain becomes more difficult or uneven, they may need adjusting to suit the conditions. Turning the Preset control to maximum and increasing pressure on the lever will give more power to climb gradients, reduce pressure to slow the wheelchair if the speed increases beyond a comfortable level. Release the lever when descending a slope and the wheelchair is tending to pull the attendant. Always remember to release the lever if you are experiencing any difficulties maintaining control.
4. Under no circumstances should the person in the wheelchair operate the hand control.
5. The Powerpack has adequate power to propel a wheelchair and passenger over terrain that is normally accessible to a wheelchair. However, in situations such as hill climbing, use on gravel or wet grass, a certain amount of assistance may be required by the attendant. When used in conditions such as the above, do not allow the motor to labour excessively or stall as damage may be caused.
6. Care must always be taken when negotiating kerbs and, if in doubt, refer to the wheelchair manufacturer's instructions. We recommend that dropped kerbs are used whenever possible. If kerbs have to be negotiated, when reversing up or down kerbs, the Powerpack must be lifted clear of the ground with the strap. When climbing kerbs in a forwards direction, either lift the Powerpack clear of the kerb on the strap, or by using a small amount of power and great care the Powerpack can be an assistance to climbing the kerb. However, when going down the kerb forwards, it is advisable to use the strap and have the Powerpack clear of the ground. Never let the Powerpack crash down the kerb as this may cause damage.
7. Hands should be kept clear of the wheels at all times.

8. Always ensure your battery is adequately charged before undertaking any journey. This is indicated by the light at the top of the hand control. In the event that the battery condition indicator is showing amber and you have some distance to go before you reach your destination, you may wish to conserve the battery power for the more difficult part of the remaining journey. Simply raise the Powerpack drive wheel clear of the ground and switch the key to off. When you come to more difficult terrain, lower the drive wheel and turn the key to on. You will find that by resting the battery there is a small degree of battery recovery which will give you a little extra distance.
9. NOTE Most manufacturers provide guidance on the stability of their wheelchair and you should refer to their manual for information. However, if parked on a hill, with the wheelchair occupied, the rear stability must be considered. TGA recommend that the normal practice should be to park with the wheelchair facing down the hill, unless the wheelchair manufacturer's information states otherwise. If the Powerpack has been positioned, other than as recommended in paragraph 3 of the Fitting Instructions and the manufacturer of the wheelchair recommends a different parking method, please contact TGA for advice.
10. The standard Wheelchair Powerpack is not to be used on wheelchairs where the weight of the occupant and chair exceeds 114.30 kilograms (18 stone). The heavy duty Wheelchair Powerpack is not to be used on wheelchairs where the weight of the occupant and chair weight exceeds 165.10 kilograms (26 stone). The PLUS should not be used where the combined weight of the user, Powerpack and wheelchair exceeds 203kgs (32 stone).
11. It is important to check all the Powerpack bolts and fittings for tightness paying particular attention to the crossbar fixings and the handlebar grips, also battery terminals. This should be done initially after the first journey, then regularly at monthly intervals. Pay particular attention to the crossbar wing nut (fig. 3f) after the initial journey and check regularly to ensure it remains tight and that the Powerpack is centrally located. This is very relevant if you have a Twin Wheel Powerpack model where the greater forces involved (plus increased power and occupant weight with the Heavy Duty model) can apply additional strain on this fixing. All Twin Wheel models are fitted with two wing nuts for additional security and both should be checked regularly to ensure they are tight at all times.

## **Batteries**

1. The Wheelchair Powerpack has adequate range and power for its intended use. However to keep it working to its maximum potential means that its battery must be maintained properly. Correct charging will maximize battery life and ensure the Powerpack is always ready to go when you are. Following these instructions correctly will ensure you get the best results from your battery.
2. The battery fitted is the latest in battery technology. It is sealed and maintenance free and especially designed for powered mobility. No topping up is required. It can be stood in any position, on its side or upside down, there will be no leaks.

3. As the batteries are sealed they are acceptable for air travel. Please consult your carrier prior to departure. Please note: Each carrier reserves the right to carry what may be termed as hazardous cargo. TGA cannot be responsible for their final decision.

## **Battery Charging**

1. Always use the charger supplied with the Wheelchair Powerpack. It is designed for use with the battery supplied and any other charger may be dangerous to use or cause damage to the battery. In addition, alternative chargers will not correctly charge the battery and will void the warranty. The new charger has automatic input voltage selection between 100 & 240v AC and can therefore be used in any country of the world (with the appropriate plug/socket adaptor).
2. The charger supplied is of the very latest technology and fully automatic. It has a two colour indicator light on the front panel, showing red when the battery is charging and green when fully charged.
3. To charge, disconnect the plug and socket between the battery and the Powerpack (Fig 7) and connect the charger to the battery. To ensure correct connection this can only be done one way, red to red and black to black.
4. Connect the battery charger to the mains supply and switch on. The indicator light will illuminate green to show a correct connection has been made. At this point the charger will seek to determine whether the battery is fully charged or in need of charging. After a few minutes the light will either change to red to indicate the battery is in need of charging or if it stays green the battery is fully charged and the charger can be disconnected.
5. When the battery is fully charged the indicator light will change from red to green. At this point the charger stops charging the battery. The battery cannot be overcharged and the charger can either be disconnected completely or left plugged in and switched on until the Powerpack is required for further use. However we would suggest not leaving on indefinitely. We recommend an overnight charge as this will provide adequate time for your battery to receive a complete charge and will take advantage of any off-peak electricity rates. The charge time may be as much as ten hours depending on the state of charge in the battery. This time may increase as the battery gets older. It is not advisable to put batteries on charge that are already fully charged.
6. Always disconnect the mains supply before disconnecting the battery. Do not leave the charger connected to the battery when the mains supply is either switched off or disconnected. This may cause the battery to discharge.
7. The battery should not be run completely flat or you may find that you are unable to recharge it. (Contact your local dealer or TGA.)
8. If the Powerpack is going to be put away or stored for some time, always ensure the battery is fully charged before storing. To avoid battery deterioration, the Wheelchair Powerpack should not be left for a period of two months or more without charging.

9. Although to get out of trouble the batteries can be put on charge for a short period of time, continual charging in this manner will shorten battery life and performance will be reduced.
10. For the best results and to prolong battery life try to run the battery down by at least 50% before recharging and in addition it is always best to go through a complete charge cycle each time.
11. For the best results it is very important that your battery is cycled for the first 10-15 charges. This means run it down as much as you safely can in use and then give it a full charge. Your battery will not work at its best until this process has been carried out.

### **Care! Warning**

- Do not allow charger to get wet or use in the rain
- Do not smoke or use a naked flame while your batteries are being charged
- Do not use the charger if it has received a sharp blow, been dropped or otherwise misused in any way. Take it to a qualified technician for inspection
- Do not dismantle the charger. This will void the warranty.
- For a complete charge – Do not switch off, unplug or interrupt the recharge cycle until the charging cycle has completed. Make sure that the charger indicator light is green before you unplug your charger.

### **Transportation of the Wheelchair Powerpack**

1. Never transport a wheelchair in any type of vehicle with the Powerpack attached.
2. During transportation, always ensure that the wheelchair, Powerpack, battery and any associated components are securely strapped down and stowed safely.
3. For the purpose of air transportation, the battery fitted to the Wheelchair Powerpack is classified as “non-spillable” under IATA Dangerous Goods Regulations. The battery complies with Special Provision A67 and packaging instruction 806 and may be regarded as non-dangerous. A certificate qualifying this is available from TGA.
4. All Wheelchair Powerpacks are tested and subjected to a pre-delivery inspection to ensure the product reaches you in first class condition.

## **Warranty**

This is to certify that your TGA product is warranted by TGA for a period of twelve months from the date of purchase subject to the following conditions:

- This warranty is extended only to the original purchaser/user of the TGA product identified by the product serial number located on the frame. This warranty is not transferable.
- TGA will repair or replace free of charge any part found upon inspection by an authorized representative of TGA to be defective in material and/or workmanship.
- If a defect or fault is discovered, the dealer from where the product was purchased should be notified immediately.

## **Warranty Exclusions**

- Tyres and wheels (these are normal wear components and replacement is not warranted).
- TGA will not be responsible for defects caused by abuse in return transit, vandalism, misuse, abuse, accident, negligence, alteration or misuse caused by non-observance of instructions set out in the Operator's Manual
- This warranty does not cover commercial or rental use of the Powerpack or any use other than normal.
- Returns are only accepted when the product is shipped in the original carton with original protective packaging materials installed.
- Returned goods to be sent to TGA carriage paid. If a successful warranty claim is found, TGA will pay return carriage.
- There is no other express warranty. Any and all other implied warranties are excluded. Your rights as a consumer are not affected.
- TGA Electric Leisure reserves the right to change the product specification and prices without incurring and obligation.

***Thank you for purchasing the Wheelchair Powerpack.  
We hope it helps to make life a little easier.***







A series of horizontal lines, spaced evenly down the page, intended for handwriting practice or as a template for a document.



**TGA Mobility Ltd • Woodhall Business Park • Sudbury • Suffolk • CO10 1WH**

T 01787 882244 • F 01787 882248  
sales@tgamobility.co.uk  
www.tgamobility.co.uk



TGA Mobility Ltd reserves the right to change specification and/or prices without prior notification or warning

INS08v5