



ASSEMBLY



OPERATION



COMFORT



MAINTENANCE

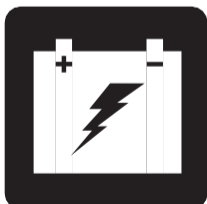

BATTERY  
CHARGING



# APEX ALUMALITE

## LITHIUM BATTERY

## OWNER'S MANUAL

---

## **INTENDED USE**

The intended use of this device is to provide mobility to persons limited to a seated position that have the capacity of operating a scooter.

***NOTE: This owner's manual is compiled from the latest specifications and product information available at the time of publication. We reserve the right to make changes as they become necessary. Any changes to our products may cause slight variations between the illustrations and explanations in this manual and the product you have purchased. The latest/current version of this manual is available on our website.***

***NOTE: This product is compliant with WEEE, RoHS, and REACH directives and requirements.***

***NOTE: This product meets IPX4 classification (IEC 60529).***

***NOTE: The Travel Scooter and its components are not made with natural rubber latex. Consult with the manufacturer regarding any after-market accessories.***



Apex Alupalite Manual

Copyright © 2020  
P4030221/Rev A/July 2020

# CONTENTS

<b>SAFETY GUIDELINES .....</b>	<b>2</b>
<b>I. SAFETY .....</b>	<b>3</b>
<b>II. YOUR TRAVEL SCOOTER .....</b>	<b>5</b>
<b>III. BATTERIES AND CHARGING .....</b>	<b>13</b>
<b>IV. OPERATION .....</b>	<b>18</b>
<b>V. COMFORT ADJUSTMENTS .....</b>	<b>20</b>
<b>VI. DISASSEMBLY AND ASSEMBLY.....</b>	<b>22</b>
<b>VII. BASIC TROUBLESHOOTING.....</b>	<b>24</b>
<b>VIII.CARE AND MAINTENANCE.....</b>	<b>26</b>

## SAFETY GUIDELINES



**WARNING!** An authorized Provider or qualified technician must perform the initial setup of this scooter and must perform all of the procedures in this manual.

The symbols below are used throughout this owner’s manual and on the scooter to identify warnings and important information. It is very important for you to read them and understand them completely.



**WARNING!** Indicates a potentially hazardous condition/situation. Failure to follow designated procedures can cause either personal injury, component damage, or malfunction. On the product, this icon is represented as a black symbol on a yellow triangle with a black border.



**MANDATORY!** These actions should be performed as specified. Failure to perform mandatory actions can cause personal injury and/or equipment damage. On the product, this icon is represented as a white symbol on a blue dot with a white border.



**PROHIBITED!** These actions are prohibited. These actions should not be performed at any time or in any circumstances. Performing a prohibited action can cause personal injury and/or equipment damage. On the product, this icon is represented as a black symbol with a red circle and red slash.

# I. SAFETY

## PRODUCT SAFETY SYMBOLS

The symbols below are used on the Travel Scooter to identify warnings, mandatory actions, and prohibited actions. It is very important for you to read and understand them completely.

*NOTE: There are more warnings identified and explained in the Consumer Safety Guide that is included with your Travel Scooter. Please become familiar with all the warnings and safety information found in the Consumer Safety Guide and refer to this resource often.*



**Read and follow the information in the owner's manual.**



**Scooter information label**

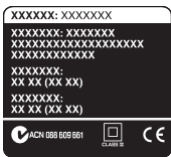

**Fully charge batteries before operating.**

**Remove key from an unattended Travel Scooter.**



**Indicates tie-down points on the Travel Scooter.**



**Does not meet ISO 7176-19 standards for occupied transport in a motor vehicle. When traveling in a motor vehicle, do not sit in your Travel Scooter.**



**Manufactured in**

# I. SAFETY

## GENERAL



**MANDATORY! Do not operate your new Travel Scooter for the first time without completely reading and understanding this owner's manual and the Consumer Safety Guide.**

Your Travel Scooter is a state-of-the-art life-enhancement device designed to increase mobility. We provide an extensive variety of products to best fit the individual needs of the Travel Scooter user. Please be aware that the final selection and purchasing decision regarding the type of Travel Scooter to be used is the responsibility of the Travel Scooter user who is capable of making such a decision and his/her healthcare professional (i.e., medical doctor, physical therapist, etc.).

The contents of this manual are based on the expectation that a mobility device expert has properly fitted the Travel Scooter to the user and has assisted the prescribing healthcare professional and/or the authorized Provider in the instruction process for the use of the product.

There are certain situations, including some medical conditions, where the Travel Scooter user will need to practice operating the Travel Scooter in the presence of a trained attendant. A trained attendant can be defined as a family member or care professional specially trained in assisting a Travel Scooter user in various daily living activities.

As you begin using your Travel Scooter during daily activities, you will probably encounter situations in which you will need some practice. Simply take your time and you will soon be in full and confident control as you maneuver through doorways, on and off elevators, up and down ramps, and over moderate terrain.

Additional general information can be found on the supplemental information sheets and booklets included in your Owner's Package. Please fully read and review the information, and keep it readily available for future reference.

Below are some precautions, tips, and other safety considerations that will help you become accustomed to operating the Travel Scooter safely.

### **PRE-RIDE SAFETY CHECK**

Get to know the feel of your Travel Scooter and its capabilities. We recommend that you perform a safety check before each use to make sure your Travel Scooter operates smoothly and safely.

#### **Perform the following inspections prior to using your Travel Scooter:**

- Check the condition of the tires. Make sure they are not damaged or excessively worn.
- Check all electrical connections. Make sure they are tight and not corroded.
- Check all harness connections. Make sure they are secured properly.
- Check the brakes to ensure they operate properly.
- Check the battery condition meter to ensure the batteries are fully charged.
- Ensure the manual freewheel lever is in drive mode before sitting on the Travel Scooter.

If you discover a problem, contact your authorized Provider for assistance. Please refer to the Contact Information insert in your Owner's Package.

## II . YOUR TRAVEL SCOOTER

### TILLER CONSOLE

The tiller console houses all controls needed to drive your Travel Scooter, including the key switch, throttle control lever, horn button, speed adjustment dial, and the battery condition meter.



**PROHIBITED! Do not expose the tiller console to moisture. In the event that the tiller console does become exposed to moisture, do not attempt to operate your Travel Scooter until the tiller console has dried thoroughly.**

#### IDENTIFICATION KEY FOR FIGURES 1 THROUGH 6

1. Horn
2. Key Switch
3. Battery Condition Meter
4. Speed Adjustment Dial
5. Throttle Control Lever
6. Charger Power Cord Receptacle (Tiller Port)\*
7. Off-board Charger Fuse

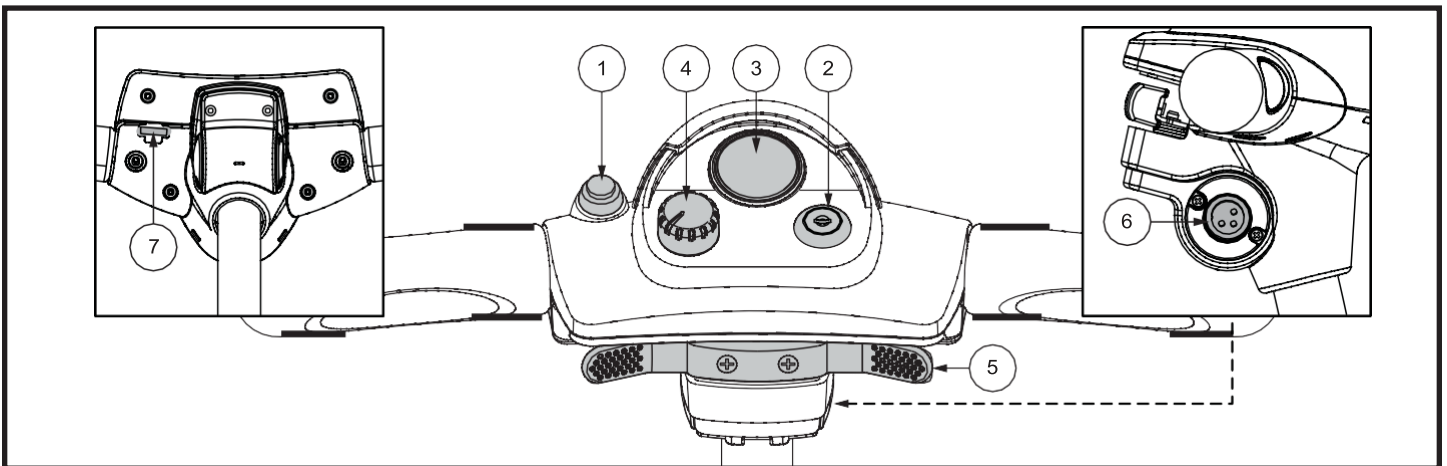

Figure 2. Tiller Console

## II . YOUR TRAVEL SCOOTER

### Horn Button

This button activates a warning horn. Your Travel Scooter must be turned on for the horn to be operational. Do not hesitate to use the warning horn when doing so may prevent accident or injury.

### Key Switch

- Insert the key into the key switch and turn it clockwise to power up (turn on) your Travel Scooter.
- Turn the key counterclockwise to power down (turn off) your Travel Scooter.



**WARNING! When faced with an emergency situation, switch off the key to power off the scooter. Use caution. Be advised that turning off power to the scooter may cause the scooter to stop abruptly. To release the emergency stop and restore driving capability to the scooter, release the throttle control lever and then switch on the key to the scooter.**

Although the key can be left in the key switch when the Travel Scooter is powered down, we recommend removing it to prevent unauthorized use of your Travel Scooter.



**WARNING! If the key is moved to the “off” position while your Travel Scooter is in motion, the electronic brakes will engage and your Travel Scooter will come to an abrupt stop!**

### Battery Condition Meter

When the key is fully inserted into the key switch and turned clockwise to power up your scooter, this meter indicates approximate battery strength. For further information on the battery condition meter, see III. “Batteries and Charging.”

### Speed Adjustment Dial

This dial allows you to preselect and limit your Travel Scooter’s top speed.

- The image of the tortoise represents the slowest speed setting.
- The image of the hare represents the fastest speed setting.

### Throttle Control Lever

This lever allows you to control the forward speed and the reverse speed of your scooter up to the maximum speed you preset with the speed adjustment dial.

## II . YOUR TRAVEL SCOOTER

*To use throttle control lever:*

**To move Forward, use either of the following:**

- Use your left thumb to push the left side of the throttle control lever.
- Use your right hand fingers to pull back on the right side of the throttle control lever.

**To move Rearward, use either of the following:**

- Use your right thumb to push the right side of the throttle control lever.
- Use your left hand fingers to pull back on the left side of the throttle control lever.

Release the throttle control lever and allow your scooter to come to a complete stop before engaging the other side of the lever. When the throttle control lever is completely released, it automatically returns to the center “stop” position and engages your scooter’s brakes.

### Lights Switch (If Equipped)

This switch controls your Travel Scooter’s lighting system.

- Toggle the switch forward to turn on the lighting system.
- Toggle the switch rearward to turn off the lighting system.



**WARNING! Scooter users are required to use their lights when visibility is restricted—day or night.**

### REAR COMPONENTS

The manual freewheel lever, anti-tip wheels, and motor/transaxle assembly are located on your Travel Scooter as shown. see **figure 7**.



**WARNING! Before placing your Travel Scooter into or taking it out of freewheel mode, remove the key from the key switch. Never sit on a Travel Scooter when it is in freewheel mode. Never put a Travel Scooter in freewheel mode on any incline.**

### Motor/Transaxle Assembly

The motor/transaxle assembly is an electromechanical unit that converts electrical energy from your Travel Scooter’s batteries into the controlled mechanical energy that drives the Travel Scooter’s wheels.

### Manual Freewheel Lever -

Whenever you need or want to push your Travel Scooter for short distances, you can put it in freewheel mode.

1. Locate the manual freewheel lever at the top right of the rear section.
2. Push forward on the manual freewheel lever to disable the drive system and the brake system. You may now push your Travel Scooter.
3. Push the manual freewheel lever rearward to reengage the drive and the brake systems; this takes your Travel Scooter out of freewheel mode.

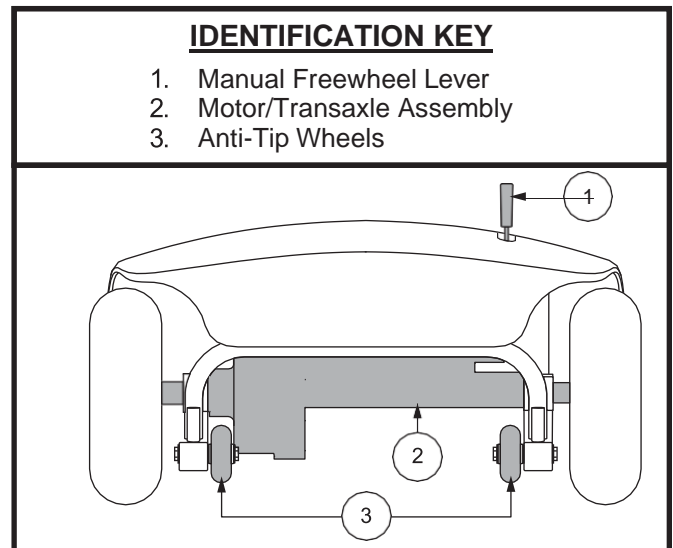

**Figure 7. Rear Components**



## II . YOUR TRAVEL SCOOTER



**WARNING!** When your Travel Scooter is in freewheel mode, the braking system is disengaged.

- Disengage the drive motor only on a level surface.
- Ensure the key is removed from the key switch.
- Stand to the side of the scooter to engage or disengage freewheel mode. Never sit on a scooter to do this.
- After you have finished pushing your Travel Scooter, always return it to the drive mode to lock the brakes.

### IDENTIFICATION KEY

1. Manual Freewheel Levers
2. Anti-tip Wheels

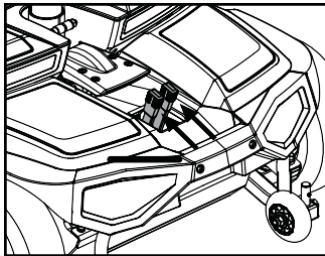

Freewheel Mode (Drive Disengaged)

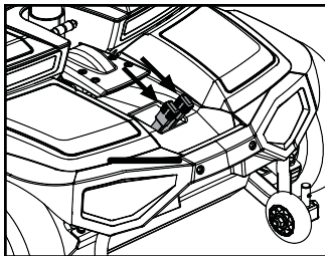

Drive Mode (Drive Engaged)

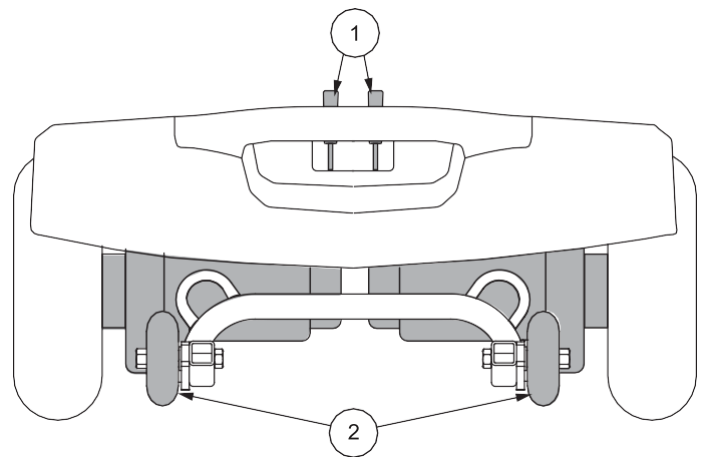

Figure 8. Rear Components

### Manual Freewheel Levers -

For your convenience, your travel scooter has a manual freewheel lever on the motor. Manual freewheel levers enable you to disable the drive system in order to maneuver the Travel Scooter manually. See figure 8.



**WARNING!** Do not use the Travel Scooter while the drive motors are disengaged! Do not disengage the drive motors when the travel scooter is on an incline or decline, as the unit could roll on its own! Only engage the freewheel mode when on a level surface.



**WARNING!** It is important to remember that when your Travel Scooter is in freewheel mode, the braking system is disengaged.

*NOTE: It is strongly recommended that you do not charge your batteries while in freewheel mode.*

*NOTE: You must turn off the power before disabling the drive systems; otherwise, you may get an error code on the scooter. To clear this code, turn off the scooter and place the travel scooter in drive mode. Then turn on the scooter. The error message should be cleared. If not, contact an authorized Provider.*

## II . YOUR TRAVEL SCOOTER

### To engage or disengage the drive system:

1. Locate the levers on the rear section of the scooter. **See figure 8.**
2. Pull the two levers toward the rear of the travel scooter to engage the drive motors (drive mode).
3. Push the two levers toward the front of the travel scooter to disengage the drive motors (freewheel mode).

If a lever is difficult to move in either direction, rock your travel scooter back and forth slightly. The lever should then move to the desired position.



**WARNING! Do not use the freewheel lever handles as tie-down points to secure this product.**

### Anti-Tip Wheels

The anti-tip wheels are an integral and important safety feature of your Travel Scooter. They are bolted to the frame at the rear of the Travel Scooter.



**PROHIBITED! Do not remove the anti-tip wheels or modify your Travel Scooter in any way that is not authorized by your Provider.**



**WARNING! The anti-tip wheels may cause interference with the smooth transition of your Travel Scooter when ascending or descending a curb. Contact your authorized Provider for more information.**

### Main Circuit Breaker (Reset Button)

When the voltage in your Travel Scooter's batteries becomes low or the Travel Scooter is heavily strained because of excessive loads or steep inclines, the main circuit breaker may trip to protect the motor and electronics from damage. **See figure 9.**

- The main circuit breaker reset button pops out when the breaker trips.
- When the breaker trips, the entire electrical system of your Travel Scooter shuts down.
- Allow a minute or two for your Travel Scooter's electronics to "rest."
- Push in the reset button to reset the main circuit breaker.
- If the main circuit breaker trips frequently, you may need to charge your batteries more often. You may also need to have your authorized Provider perform a load test on your Travel Scooter's batteries.
- If the main circuit breaker trips repeatedly, see your authorized Provider for service.

# II . YOUR TRAVEL SCOOTER

## BATTERY PACK

Your Travel Scooter is equipped with an innovative, easy-to-remove battery pack. A handle on the top of the battery pack makes it easy to lift the pack off of the Travel Scooter with one hand. The battery pack contains a rechargeable battery, and may contain the charger power cord receptacle, the main circuit breaker (reset button), and the battery pack fuse. See figures 9 and 10.

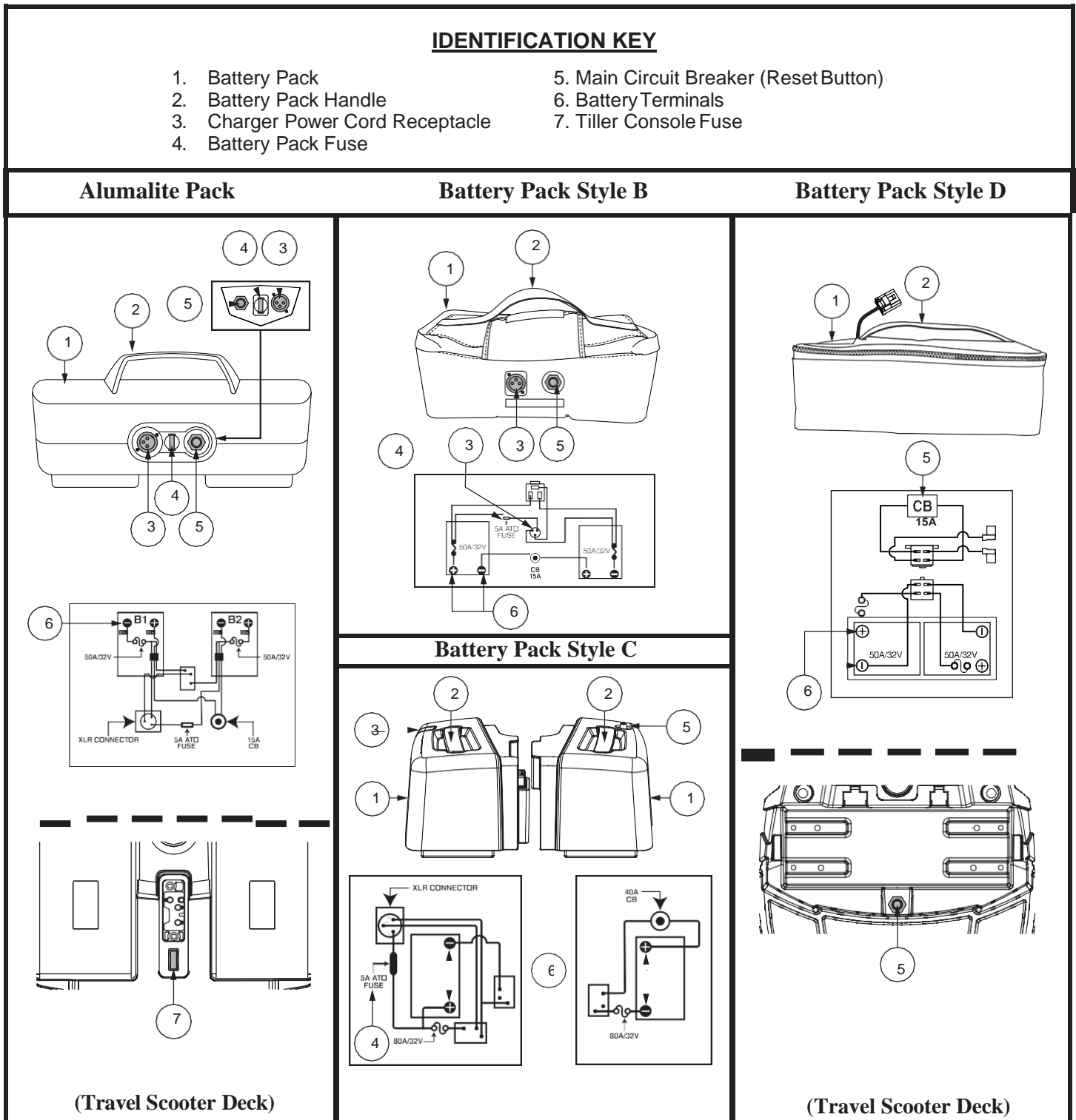

Figure 9. Battery Pack

## II . YOUR TRAVEL SCOOTER

### Charger Power Cord Receptacle

The 3-pin end of the charger power cord plugs into this receptacle. See figures 11 and 12.

### Tiller Console Fuse (If Equipped)

The fuse located under the battery pack protects the tiller console electronics. See figure 9. In the event any component of the tiller console is not responding, check this fuse. See VII. “Basic Troubleshooting” for fuse replacement instructions.

### Off-Board Battery Charger

The off-board battery charger, when plugged into the charger power cord receptacle and a standard electrical outlet, charges the Travel Scooter’s batteries. See figure 13.

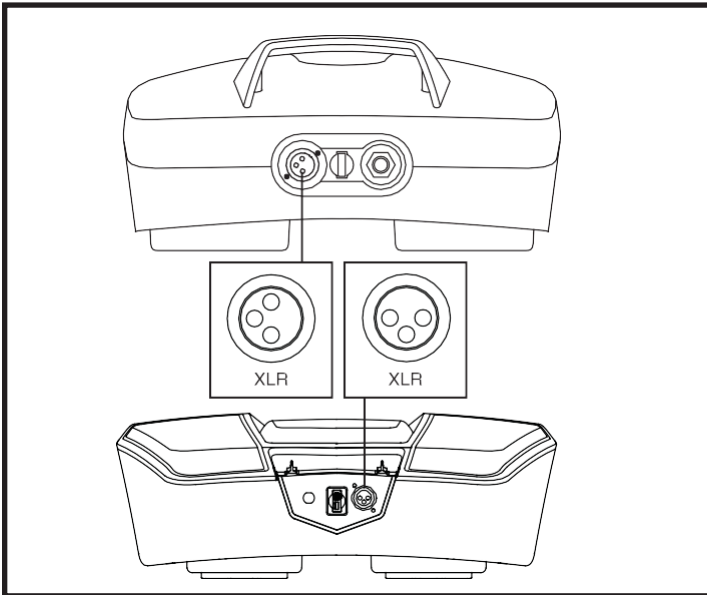

Figure 12. Charger Power Cord Receptacle (Battery Pack)

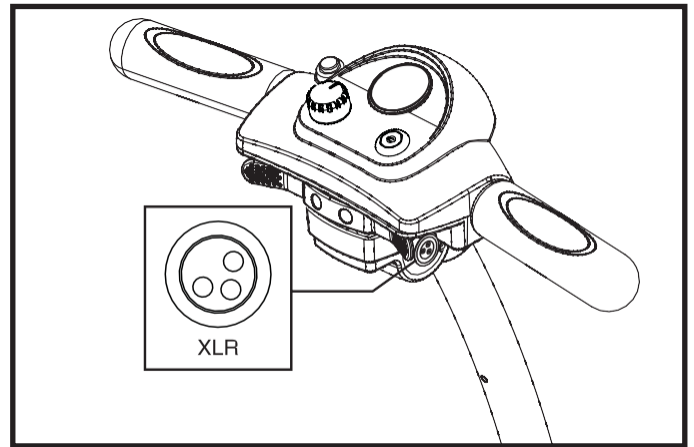

Figure 11. Charger Power Cord Receptacle (Tiller Mounted)

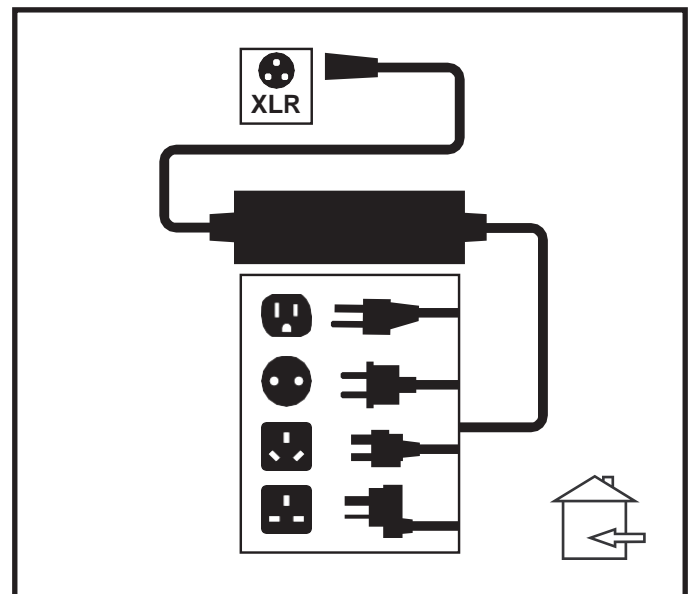

Figure 13. Off-board Battery Charger

## II . YOUR TRAVEL SCOOTER

### SECUREMENT POINTS

Always secure the Travel Scooter in a forward-facing position in the vehicle. Attach the four tie-down straps to the designated securement points. **See figure 14.** Tighten the straps to sufficiently remove all slack. Never attach tie-downs to adjustable, moving, or removable parts of the Travel Scooter such as armrests, shrouds, and wheels. These items should be removed. Position the anchor points for the rear tie-down straps directly behind the rear securement points on the Travel Scooter. The front tie-down straps should anchor to floor points that are spaced wider than the Travel Scooter to provide increased lateral stability.



**WARNING! Ensure Travel Scooters are properly secured to the motor vehicle during transport. Scooters that are not properly secured can become a hazard to the user and to other vehicle passengers in the event of a crash, sudden stopping, or swerving, as the Travel Scooter could tip or slide out of place.**

### IDENTIFICATION KEY

1. Front Securement Points
2. Rear Securement Points

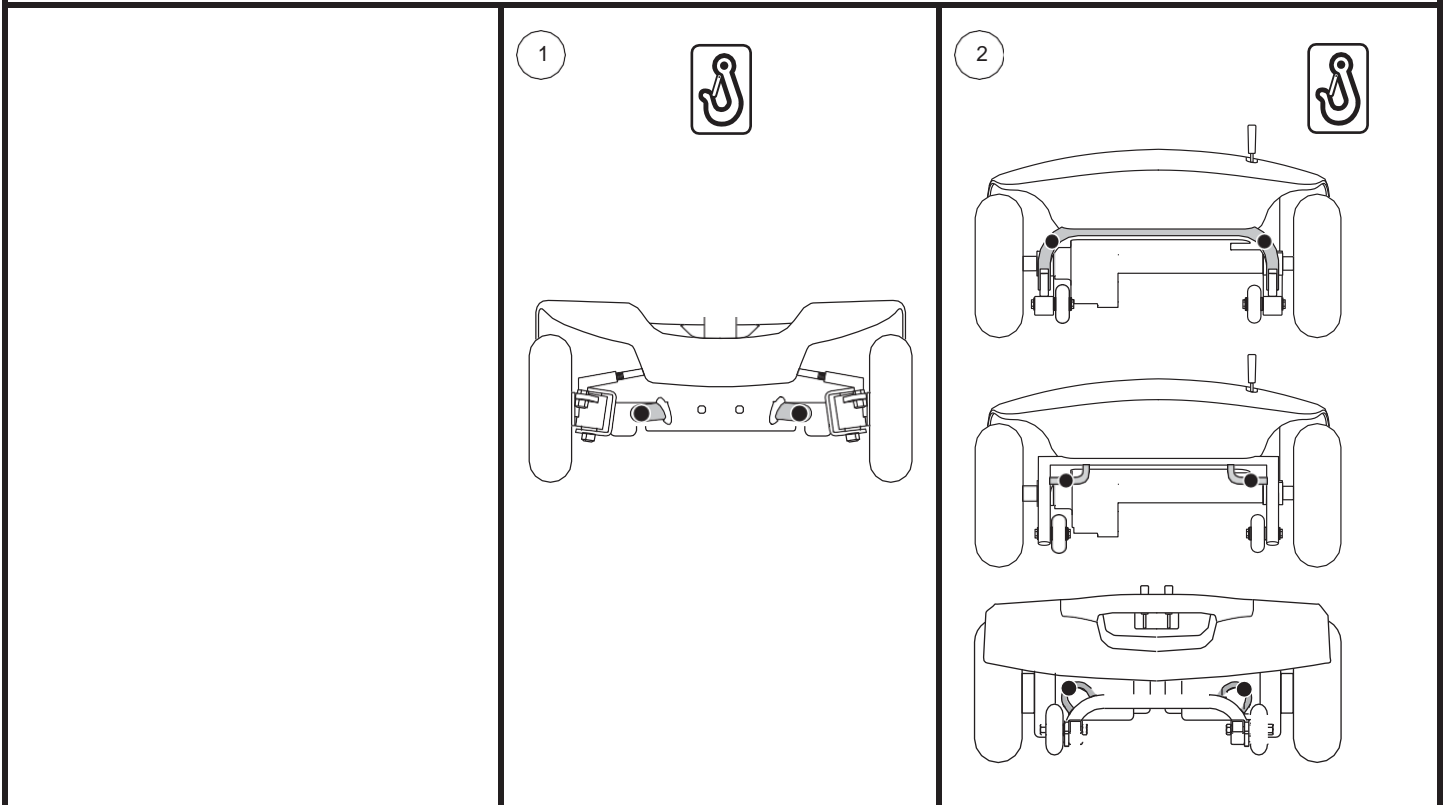

Figure 14. Securement Points (Identified with black dots)

## Batteries and Charging

### Batteries and Charging

Your scooter uses one long-lasting Lithium-Ion battery. This battery is sealed and maintenance-free. Since it is sealed, there is no need to check the electrolyte (fluid) level. Lithium-Ion batteries are designed to handle a longer and deeper discharge. Though they are similar in appearance to automotive batteries, they are not interchangeable. Automotive batteries are not designed to handle a long, deep discharge, and are unsafe for use in scooters.



**MANDATORY!** Wear goggles and gloves when handling batteries and wash hands after handling.



**WARNING!** Contact your authorized Pride Provider if you have any questions regarding the battery in your scooter.

### Charging the Battery

The battery charger is essential in providing long life for your scooter battery. It is designed to optimize your scooter's performance by charging the battery safely, quickly, and easily. The battery charger is only functional when the charger power cord is plugged into an electrical outlet.



**PROHIBITED!** Removal of grounding prong can create electrical hazard. If necessary, properly install an approved 3-pronged adapter to an electrical outlet having 2-pronged plug access.



**PROHIBITED!** Never use an extension cord to plug in your battery charger. Plug the charger directly into a properly wired standard electrical outlet.



**PROHIBITED!** Do not allow unsupervised children to play near the scooter while the battery is charging. Pride recommends that you do not charge the battery while the scooter is occupied.



**MANDATORY!** Read the battery charging instructions in this manual and in the manual supplied with the battery charger before charging the battery.



**WARNING!** Explosive gases may be generated while charging the battery. Keep the scooter and battery charger away from sources of ignition such as flames or sparks and provide adequate ventilation when charging the battery.

**WARNING!** You must recharge your scooters battery with the supplied off-board charger. Do not use an automotive-type battery charger.

**WARNING!** Inspect the battery charger, wiring, and connectors for damage before each use. Contact your authorized Pride Provider if damage is found.



**WARNING!** Do not attempt to open the battery charger case. If the battery charger does not appear to be working correctly, contact your authorized Pride Provider.

**WARNING!** Be aware that the battery charger case may become hot during charging. Avoid skin contact and do not place on surfaces that may be affected by the heat.

**WARNING!** If the battery charger is equipped with cooling slots, then do not attempt to insert objects through these slots.

**WARNING!** If your battery charger has not been tested and approved for outdoor use, then do not expose it to adverse or extreme weather conditions. If the battery charger is exposed to adverse or extreme weather conditions, then it must be allowed to adjust to the difference in environmental conditions before use indoors. Refer to the manual supplied with the battery charger for more information.



**NOTE: The scooter battery can be charged with the battery box either installed on or removed from the scooter.**

**To charge the battery using the off-board charger:**

1. Position your scooter next to a standard electrical outlet.
2. Be certain the scooters power is turned off.
3. Plug the off-board charger into the off-board charger socket of the scooter's battery pack. **See figure 12.**
4. Plug the off-board charger into the electrical outlet.
5. When the battery is fully charged, unplug the off-board charger from the electrical outlet and then from the scooter.

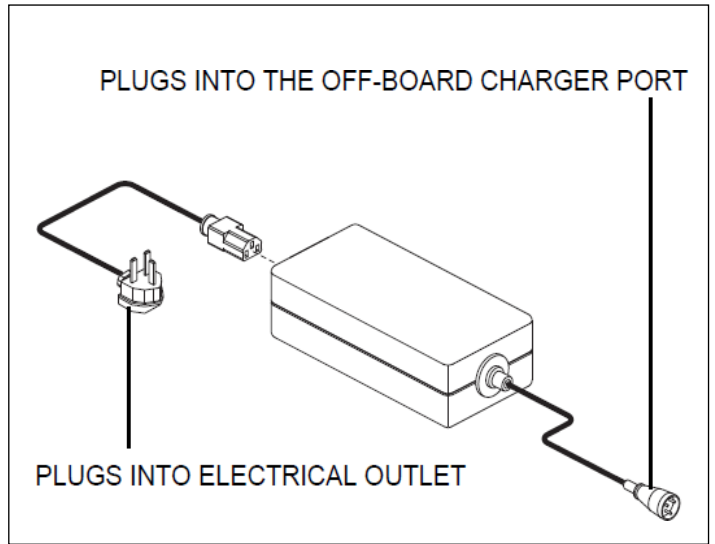

**WARNING!** The LED light colour on the charger indicates a different charger status. The LED is **RED** when the charger is not or cannot connect to the scooter. The LED is **ORANGE** when the charger is connected and charging the scooter. The LED will be **GREEN** when the scooter has finished charging.



**Note:** The LED should always be orange when the scooter is initially plugged in. If the LED immediately goes to **GREEN**, it may mean that your batteries are too discharged to allow charging or there may be an issue with your charger – In this case, please contact your Pride Service Provider for advice.

**NOTE: The battery condition meter on your scooter displays an approximate reading of battery strength. Refer to Table 1 for battery condition meter codes.**

LEDs	Battery Percentage
10	91-100% battery remaining
9	81-90% battery remaining
8	71-80% battery remaining
7	61-70% battery remaining
6	51-60% battery remaining
5	41-50% battery remaining
4	31-40% battery remaining
3	21-30% battery remaining
2	11-20% battery remaining
1	<10% battery remaining
1st LED blinking	<5% battery remaining

**Table 1. Battery Condition Meter Codes** (Please note that these values are estimated)

**To charge the battery with the battery removed from the scooter:**

1. Remove the battery from the scooter.  
**See figure 4.**
2. Position the battery next to a standard electrical outlet.
3. Plug the off-board charger into the battery charger port. **See figure 13.**
4. Plug the off-board charger into the electrical outlet.
5. When the battery is fully charged, unplug the off-board charger from the wall outlet and then from the battery box.
6. Reinstall the battery box to the scooter.

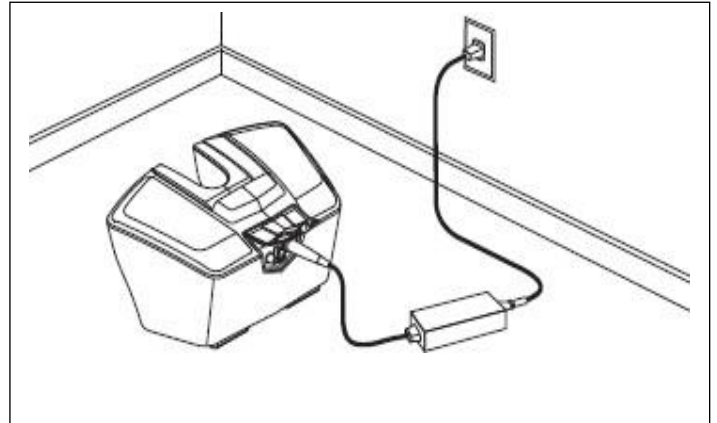

**Figure 13. Battery Charging with the Battery Pack Removed**

**NOTE: Turn off the power to the scooter before removing the battery box.**

### Frequently Asked Questions (FAQs)

#### How does the charger work?

The battery charger takes the standard electrical outlet voltage (alternating current) and converts it to 24V DC (direct current). The battery uses a direct current to run your scooter. When the battery voltage is low, the charger works harder to charge the battery. As the battery voltage approaches full charge, the charger does not work as hard to complete the charging cycle. When the battery is fully charged, the amperage from the charger is nearly at zero. This is how the charger maintains a charge but does not overcharge the battery.

#### Can I use a different battery charger?

You should use the charger supplied with the scooter. It is the safest, most efficient tool to charge the battery. We do not recommend using other types of chargers (e.g., an automotive battery charger).

**NOTE: Your scooter's charger will not operate after the battery has been discharged to nearly zero capacity. If this happens, call an authorised Pride Provider for assistance.**

#### How often must I charge the battery?

Many factors come into play when deciding how often to charge the battery. You may use your scooter all day on a daily basis or you may not use it for weeks at a time.

##### ■ Daily Use

If you use your scooter on a daily basis, charge the battery as soon as you are finished using your scooter. Your scooter will be ready each morning to give you a full day's service. It is recommended that you charge the battery at least 8 to 14 hours after daily use. Pride recommends that you charge your battery for an additional 4 hours after the battery charger indicates that charging is complete.

##### ■ Infrequent Use

If you use your scooter infrequently (once a week or less), you should charge the battery at least once per week for 12 to 14 hours.

**NOTE: Keep your battery fully charged and avoid deeply discharging your battery. Refer to the manual supplied with the battery charger for charging instructions.**



### **How can I get maximum range or distance per charge?**

Rarely do you have an ideal driving situation such as smooth, flat, hard terrain with no wind, hills, or curves. More often you are presented with hills, pavement cracks, uneven and loosely packed surfaces, curves, and wind. All of these factors will affect the distance or running time per battery charge. Below are a few suggestions for obtaining the maximum range per charge:

- Always charge the battery fully prior to your trip.
- Plan your trip in advance to avoid inclines if possible.
- Limit baggage weight to essential items.
- Try to maintain an even speed and avoid stop-and-go driving.

### **What type of battery should I use?**

We recommend a Pride-supplied Lithium-Ion battery that is sealed and maintenance-free. Refer to the specifications table for more information regarding the battery used with your scooter.



**WARNING! Corrosive chemicals contained in batteries. Use only Lithium-Ion batteries to reduce the risk of leakage or explosive conditions.**

### **Why does my new battery seem weak?**

Like nickel-cadmium batteries, Lithium-Ion batteries have a “memory” effect. Lithium-Ion batteries are specifically designed to provide power, drain down their charge, and then accept a relatively quick recharge. If the batteries are continually recharged after only being partially discharged, they lose their ability to hold a full charge.

We work closely with our battery manufacturer to provide a battery that best suits your scooter’s specific demands. Fresh batteries arrive regularly at Pride and are promptly shipped with a full charge. During shipping, the battery encounters temperature extremes that may influence initial performance. Heat robs the charge from the battery, and cold slows the power available and extends the time needed to recharge the battery (just as with a car battery).

It might take a few days for the temperature of the battery to stabilize and adjust to its new ambient temperature. More importantly, it will take a few “charging cycles” (a full drain—then a full recharge) to establish the critical chemical balance that is essential to the battery’s peak performance and long life. It will be well worth it to take the time to break in your battery properly.

### **How can I ensure maximum battery life?**

A fully charged battery will provide reliable performance and extended battery life. Keep your scooter’s battery fully charged whenever possible. Batteries that are infrequently charged, repeatedly charged after only a partial discharge, or stored without a full charge may be permanently damaged, causing unreliable scooter operation and limited battery life.

***NOTE: The useful life of a battery is quite often a reflection of the care it receives.***

**How should I store my scooter and its battery?**

If you do not use your scooter regularly, we recommend maintaining battery vitality by charging the battery at least once per week.

If you do not plan on using your scooter for an extended period, fully charge the battery prior to storage. Disconnect the battery, and store the scooter in a warm, dry environment. Avoid temperature extremes, such as freezing and excessively hot conditions, and never attempt to charge a frozen battery. A cold or frozen battery should be warmed for several days prior to recharging.

**What about public transportation?**

The Pride-supplied Lithium-Ion batteries are designed for application in scooters and other mobility vehicles. Transport of the item on commercial aircraft is subject to government regulations and airline policy. We suggest you contact the carrier's ticket counter in advance to determine that carrier's specific requirements, and to ensure your scooter and its Lithium-Ion battery are permitted.

**What about shipping?**

If you wish to use a freight company to ship your scooter to your final destination, repack your scooter in the original shipping container if possible and ship the battery in a separate box.

# IV. OPERATION

## BEFORE GETTING ONTO YOUR TRAVEL SCOOTER

- Have you fully charged the batteries? See III. “Batteries and Charging.”
- Is the manual freewheel lever in the drive (rearward) position? Never leave the manual freewheel lever in the forward position unless you are manually pushing your Travel Scooter.
- Ensure the tiller lock knob is in the unlocked position. See VI. “Disassembly and Assembly.”
- Ensure the air temperature is between -13°F/-25°C to 122°F/50°C.

## GETTING ONTO YOUR TRAVEL SCOOTER

1. Make certain that the key is removed from the key switch.



**WARNING! Never attempt to get onto or off of your Travel Scooter without first removing the key from the key switch. This will prevent the Travel Scooter from moving if accidental throttle control lever contact is made.**

2. Stand at the side of your Travel Scooter.
3. Disengage the seat rotation lever and rotate the seat until it is facing you.
4. Make certain that the seat is secured into position.
5. Position yourself comfortably and securely in the seat.
6. Disengage the seat rotation lever and rotate the seat until you are facing forward.
7. Make certain that the seat is secured into position.
8. Make certain that your feet are safely on the floorboard.

## PRE-RIDE ADJUSTMENTS AND CHECKS

- Is the seat at the proper height? See V. “Comfort Adjustments.”
- Is the seat secured into place?
- Is the tiller at a comfortable setting and secured into place? See V. “Comfort Adjustments.”
- Is the key fully inserted into the key switch and turned clockwise to the “on” position?
- Does the Travel Scooter’s horn work properly?
- Is your proposed path clear of people, pets, and obstacles?
- Have you planned your route to avoid adverse terrain and as many inclines as possible?

*NOTE: Use caution when operating your scooter on delicate surfaces as scuffing and/or marking may occur.*

## OPERATING YOUR TRAVEL SCOOTER

**WARNING! The following can adversely affect steering and stability while operating your Travel Scooter:**



- **Holding onto or attaching a leash to walk your pet.**
- **Carrying passengers (including pets).**
- **Hanging any article from the tiller.**
- **Towing or being pushed by another motorized vehicle.**

**WARNING! Keep both hands on the tiller and your feet on the floorboard at all times while operating your Travel Scooter. This driving position gives you the most control over your vehicle.**

- Set the speed adjustment dial to your desired speed.
- Press your thumb against the appropriate side of the throttle control lever.
- The electromechanical disc park brake automatically disengages and the Travel Scooter accelerates smoothly to the speed you preselected with the speed adjustment dial.
- Pull on the left handgrip to steer your Travel Scooter to the left.
- Pull on the right handgrip to steer your Travel Scooter to the right.
- Move the tiller to the center position to drive straight ahead.
- To stop, slowly release the throttle control lever. The electronic brakes will automatically engage when your Travel Scooter comes to a stop.

## IV. OPERATION

*NOTE: Your Travel Scooter's reverse speed is slower than that of the forward speed you preset with the speed adjustment dial.*

### GETTING OFF OF YOUR TRAVEL SCOOTER

1. Bring your Travel Scooter to a complete stop.
2. Remove the key from the key switch.



**WARNING! Never attempt to get onto or off of your Travel Scooter without first removing the key from the key switch. This will prevent the Travel Scooter from moving if accidental throttle control lever contact is made.**

3. Disengage the seat rotation lever and rotate the seat until you are facing toward the side of your Travel Scooter.
4. Make certain that the seat is secured into position.
5. Carefully and safely get out of the seat and stand to the side of your Travel Scooter.
6. You can leave the seat facing to the side to facilitate boarding your Travel Scooter next time.

### POWER DOWN TIMER FEATURE

Your Travel Scooter is equipped with an energy saving automatic power down timer feature designed to preserve your Travel Scooter's battery life. If you mistakenly leave the key in the key switch and in the "on" position but do not use your Travel Scooter for approximately 20 minutes, the Travel Scooter's controller shuts down automatically.

If the power down timer feature takes effect, perform the following steps to resume normal operation.

1. Remove the key from the key switch.
2. Reinsert the key and power up your Travel Scooter.

# V. COMFORT ADJUSTMENTS

## TILLER ANGLE ADJUSTMENT (See figure 23)

**WARNING!** Remove the key from the key switch before adjusting the tiller or the seat. Never attempt to adjust the tiller or the seat while the Travel Scooter is in motion.



**WARNING!** Prior to operating the scooter, push and pull on the tiller to ensure that the angle adjustment mechanism is secure. Inspect the tiller adjustment knob and the angle adjustment mechanism to ensure that they are fully engaged. If there is movement in the tiller, check to make sure that the tiller adjustment knob is fully tightened.

**NOTE:** In order to fully lower the tiller, you must first remove the seat and battery pack. Remove the seat by pulling it straight up and off of the Travel Scooter.

## SEAT ROTATION ADJUSTMENT

The seat rotation lever, located on the right side of the seat base, secures the seat into several positions. See figure 24.

1. Pull up on the seat rotation lever to disengage the seat.
2. Rotate the seat to the desired position.
3. Release the lever to secure the seat into place.

## ARMREST WIDTH ADJUSTMENT

The armrest width can be adjusted inward or outward.

1. Loosen the armrest adjustment knobs. See figure 24.
2. Use the attached ring to pull and remove the detent pins.
3. Slide the armrests in or out to the desired width.
4. Align the adjustment holes on the seat frame and armrest, then reinsert the detent pins.
5. Tighten the armrest adjustment knobs.

## SEAT HEIGHT ADJUSTMENT

The seat can be repositioned to different heights. See figure 25.

1. Remove the seat and battery pack from your Travel Scooter.
2. Use the attached ring to pull and remove the detent pin from the lower seat post.
3. Raise or lower the upper seat post to the desired seat height.
4. While holding the upper seat post at that height, align the adjustment holes of the upper and lower seat posts.
5. Fully insert the detent pin.
6. Replace the battery pack and seat.

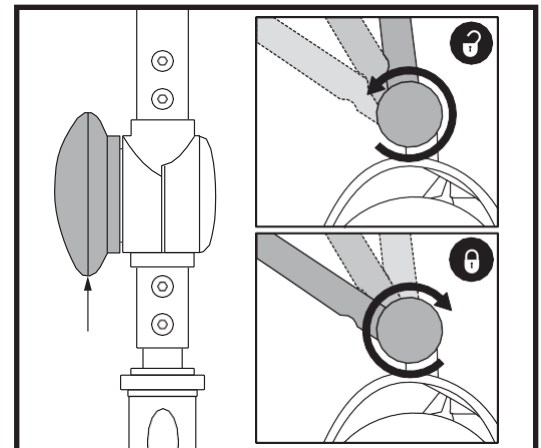

Figure 23. Tiller Adjustment Knob

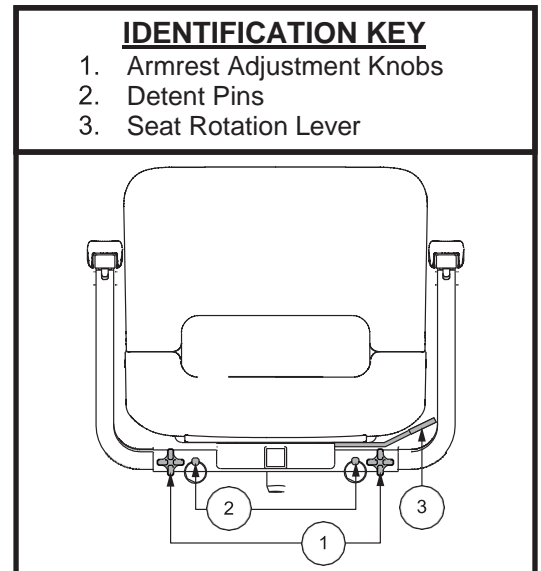

Figure 24. Seat Adjustments

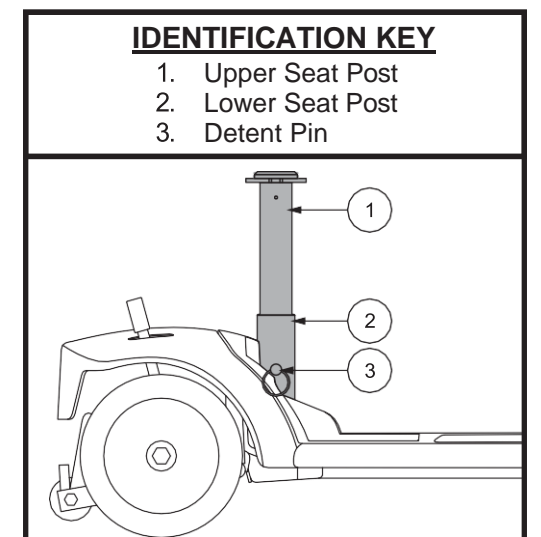

Figure 25. Seat Height Adjustment



# V. COMFORT ADJUSTMENTS

## POSITIONING BELT (OPTIONAL)

Your scooter seat may be equipped with an auto-type positioning belt that can be adjusted for operator comfort. See figure 29 or 30. The positioning belt is designed to help support the operator so that he or she does not slide down or forward in the seat. The positioning belt is not designed for use as a restraining device.



**WARNING!** The positioning belt should be secured at all times. Never allow the positioning belt to hang or drag on the floor as it may become entangled.

### To install the positioning belt (if required):

1. Remove the seat from your scooter.
2. Place the seat upside down so that you can see the bottom of the seat base. See figure 28.
3. Use a wrench to remove the two rear bolts on the outermost part of the seat frame.
4. Insert the bolt through the appropriate ends of the positioning belt and then reinstall the bolts back into the seat frame.
5. Tighten the bolts.

### Metal Tab Style Positioning Belt

#### To adjust the positioning belt for operator comfort:

1. Insert the metal tab on the right side of the belt into the plastic housing on the opposite strap until you hear a “click.” See figure 29.
2. Pull the strap on the right side of the belt until it is secure, but not so tight as to cause discomfort.

#### To release the positioning belt:

1. Press the push button mechanism on the plastic housing.

### Reusable Hook and Loop Fastener Style Positioning Belt

#### To adjust the positioning belt for operator comfort:

1. Align the two sides of the belt placing the looped-end side directly above the coarser side (“hook”) of the opposite belt. Press firmly together to fasten. See figure 30.

#### To release the positioning belt:

1. Grasp the looped-end side of the belt and pull up to detach from the other side of the belt.

**MANDATORY!** Make sure the positioning belt is properly secured to the scooter and is adjusted for operator comfort before each use.



**MANDATORY!** Inspect the positioning belt for loose parts or damage, including tears, worn spots, bent hardware, or damaged latch mechanisms, dirt or debris, before each use of the scooter. If you discover a problem, contact your authorized Provider for maintenance and repair.

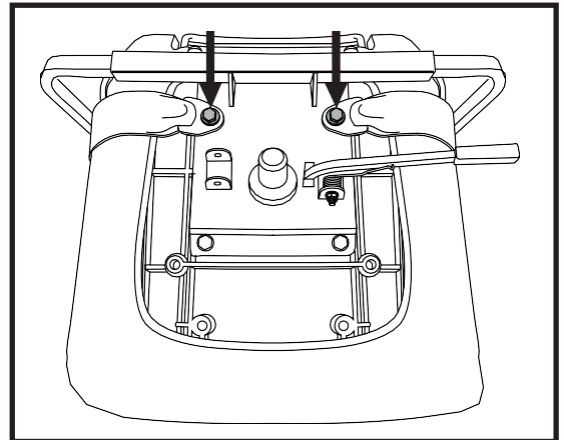

Figure 28. Positioning Belt Bolts

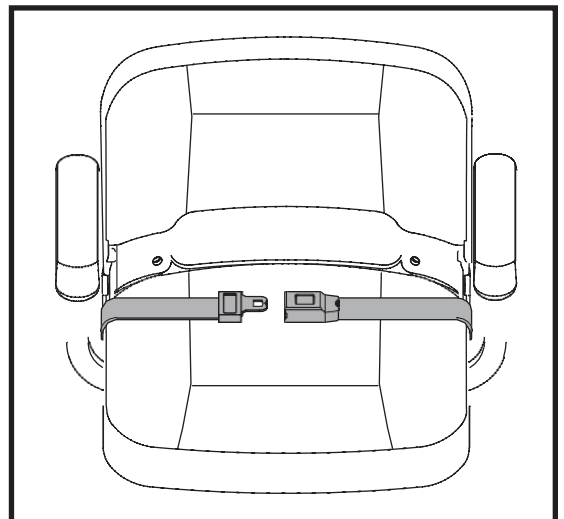

Figure 29. Positioning Belt - Metal Tab Style

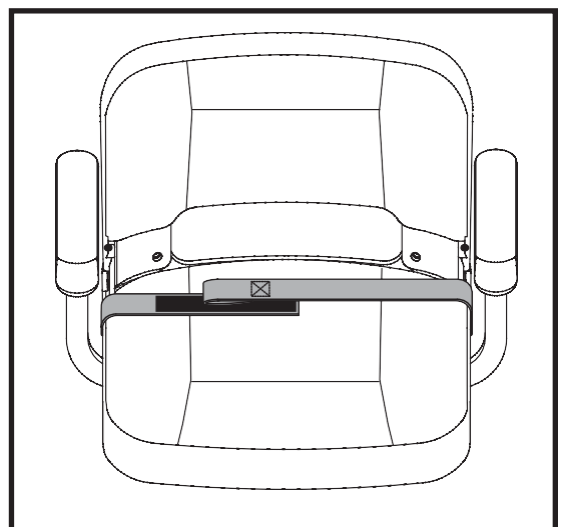

Figure 30. Positioning Belt - Reusable Hook and Loop Fastener Style

# VI. DISASSEMBLY AND ASSEMBLY

## DISASSEMBLY

You can disassemble the Travel Scooter into several pieces: the seat, the under-seat storage, the rear section, the front section, the basket and the battery pack, **See figure 31**. No tools are required to disassemble or assemble your Travel Scooter. Always disassemble or assemble your Travel Scooter on a level, dry surface with sufficient room for you to work and move around—about 5 feet (1.5 meters) in all directions. Remember that some Travel Scooter components are heavy and you may need assistance when lifting them.



**WARNING! Do not lift weight beyond your physical capability. Ask for assistance when necessary while disassembling or assembling your Travel Scooter.**

**WARNING! Do not pick up the seat frame or scooter by the armrests. They are free to pivot, and you may lose control of the seat if they do so.**

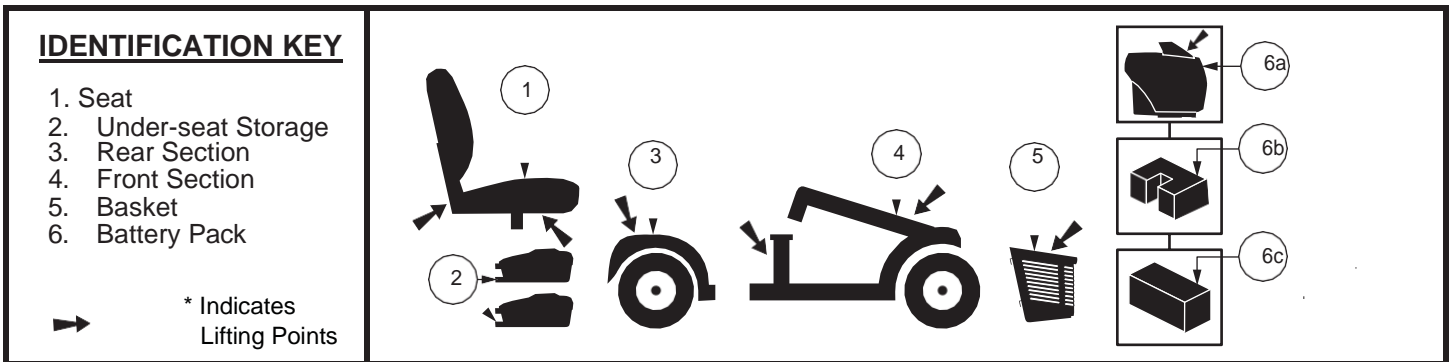

Figure 31. Disassembled Travel Scooter

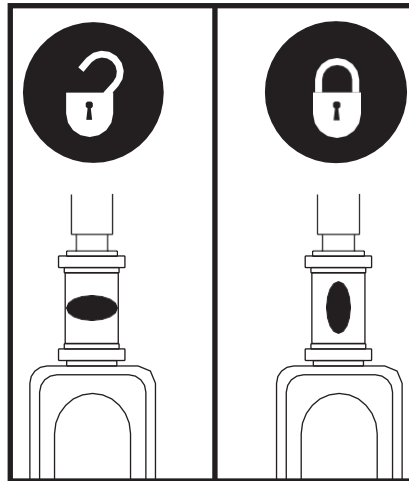

Figure 32. Tiller Lock Knob

## DISASSEMBLY PROCEDURES

1. Remove the key from the key switch and then lock the tiller in the straight-ahead position by pushing the tiller lock knob in and turning it clockwise 90°. **See figure 32**. The front wheel must face forward in order to lock the tiller.
2. Remove the seat by lifting it straight up and off of the Travel Scooter. If you encounter resistance when removing the seat, disengage the seat rotation lever and swivel the seat back and forth while lifting up on the seat.
3. Remove the battery pack by lifting the pack straight up and off the Travel Scooter.



## VI. DISASSEMBLY AND ASSEMBLY

### FRAME SEPARATION

1. With the seat and battery pack removed (see Disassembly Procedures on previous page), lower the tiller and tighten the tiller adjustment knob. **See figure 23.**
2. Lift up on the frame release lever, and pivot the rear section backwards, until the frame hooks are no longer resting on the lower frame tube.
3. Slowly separate the two sections of the Travel Scooter. **See figure 33.**

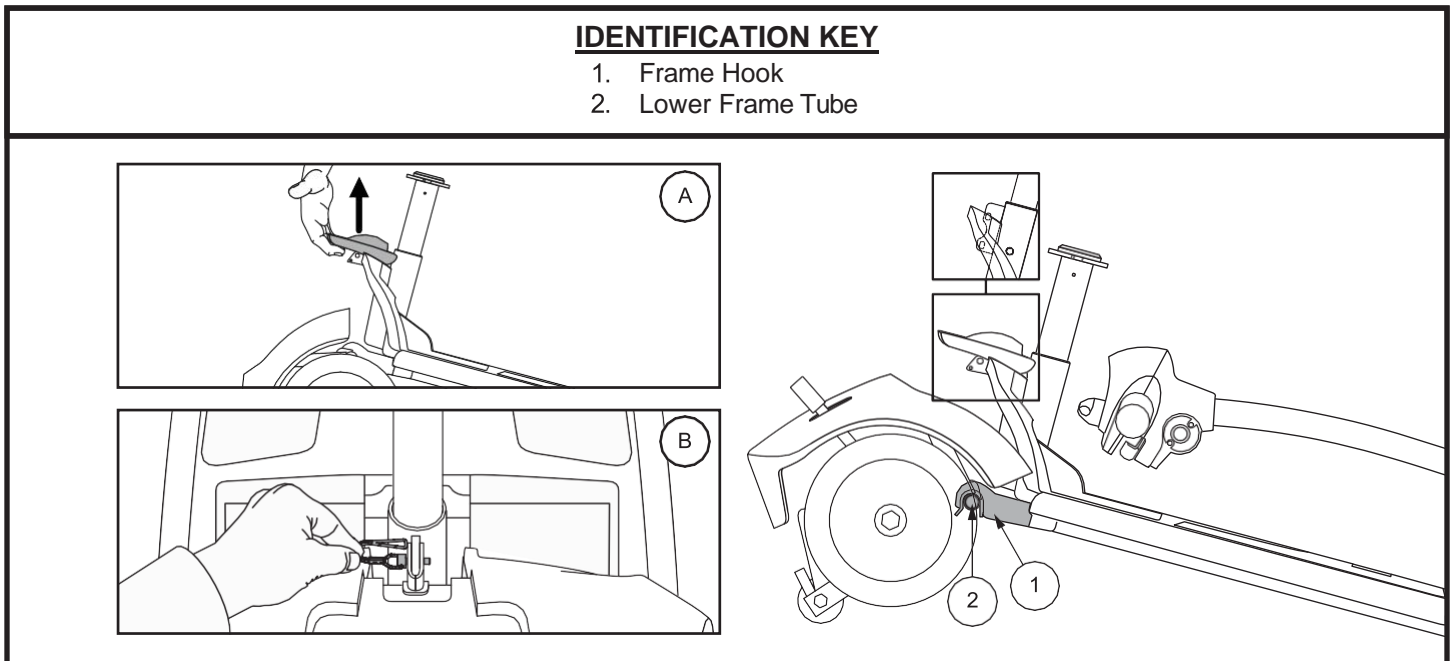

Figure 33. Frame Release Lever (Style A) and Frame Release Lock-up Pin (Style B)

### ASSEMBLY

**NOTE:** Before attempting assembly, tilt the rear half of the Travel Scooter slightly back on the anti-tip wheels as shown in figure 33.

1. Use the frame release lever to lift the front section as you align the frame hooks of the front section with the lower frame tube of the rear section. **See figure 33.**
2. Once the frame hooks are over the lower frame tube, lower the front section and pivot the rear section simultaneously. This will engage the frame lock-up automatically.
3. Raise the tiller and fully tighten the tiller adjustment knob. **See figure 23.**
4. Reinstall the battery pack.
5. Reinstall the seat and rotate it until it is secured into place.
6. Unlock the tiller by turning the tiller lock knob 90° counterclockwise. **See figure 32.**



**WARNING!** After assembly, make absolutely certain the tiller lock knob is in the unlocked position before riding your Travel Scooter.

## VII . BASIC TROUBLESHOOTING

Any electromechanical device occasionally requires some troubleshooting. However, most of the problems that may arise can usually be solved with a bit of thought and common sense. Many of these problems occur because the batteries are not fully charged or because the batteries are worn down and can no longer hold a charge.

### DIAGNOSTIC CODES

The diagnostic codes for your Travel Scooter are designed to help you perform basic troubleshooting quickly and easily. A diagnostic code will sound and/or flash in the event one of the conditions listed below develops. Depending on the model you own, your Travel Scooter will communicate by one of the coding methods as follows:

1. A diagnostic code will begin, depending on model, with a series of fast beeps and/or flashes directly followed by slower beeps and/or flashes which indicates the actual code. The code is only beeped and/or blinked once. To repeat the diagnostic code, remove the key, then reinsert it and turn it to the “on” position, **OR**
2. A diagnostic code will identify the condition, pause, then repeat the code. The diagnostic code will continue to alert you in this manner until the scooter is turned off.

**NOTE: Your Travel Scooter will not run unless the diagnostic code condition is resolved and the Travel Scooter has been turned off, then turned back on.**

DIAGNOSTIC CODE	CONDITION	SOLUTION
■ (1)	Battery voltage is too low to operate the Travel Scooter.	Charge batteries as soon as possible.
■■ (2)	Battery charge is too low.	Charge batteries.
■■■■ (3)	The Travel Scooter’s battery voltage is too high to operate the scooter, or the charger is still connected to the off-board charger port.	Unplug charger and/or turn key off, then back on again. If traveling down a slope, reduce Travel Scooter speed to the minimum setting.
■■■■■ (4)	Current limit time out.	Turn the Travel Scooter off for a few minutes, then turn your Travel Scooter back on.
■■■■■■ (5)	The manual freewheel lever is in the (forward) freewheel position.	Remove the key from the key switch, then push the manual freewheel lever to the drive (rearward) position and restart your Travel Scooter.
■■■■■■■ (6)	Throttle control lever not at center position at start up.	Verify that the batteries are fully charged. If the batteries are fully charged, then return the throttle control lever to center position, turn Travel Scooter off then back on.
■■■■■■■■ (7)	Speed pot error.	Contact your authorized Provider for assistance.
■■■■■■■■■ (8)	Motor volts error.	Contact your authorized Provider for assistance.
■■■■■■■■■■ (9)	Other internal errors.	Contact your authorized Provider for assistance.

### What if my Travel Scooter does not move when I press the throttle control lever?

- When the manual freewheel lever is pushed forward, the brakes are disengaged and all power to the motor/transaxle assembly is cut.
- Pull back on the manual freewheel lever, turn the Travel Scooter off, and then back on to return to normal operation.

## VII. BASIC TROUBLESHOOTING

### What if all the systems on my Travel Scooter seem to be “dead”?

- Make certain that the key is in the “on” position.
- Check that the batteries are fully charged.
- Push in the main circuit breaker reset button. See II. “Your Travel Scooter.”
- Make certain that the battery pack is seated properly.
- Be sure the power down timer feature has not been activated. See IV. “Operation.”
- Check the tiller console fuse located under the battery pack.

### To check a fuse:

1. Remove the fuse by pulling it out of its slot.
2. Examine the fuse to be sure it is blown.
3. Insert a new fuse of the proper rating.



**WARNING! The replacement fuse must exactly match the rating of the old fuse. Failure to use properly rated and approved fuses may cause damage to the electrical system.**

### What if the Travel Scooter’s batteries won’t charge?

- Check the fuse located on the battery pack or the console. Replace if necessary.
- During the charging process, if the charger LEDs never indicate a full charge, check the fuse located on the battery pack or the console. Replace if necessary, or have your authorized Provider or qualified technician check and/or replace the fuse.
- Ensure both ends of the charger power cord are connected properly.
- If the battery pack fuse continually blows, contact your authorized Provider for service.

### What if the main circuit breaker repeatedly trips?

- If the main circuit breaker trips repeatedly, see your authorized Provider for service.
- Charge the Travel Scooter’s batteries more frequently. See III. “Batteries and Charging.”
- If the problem continues, have both of your Travel Scooter’s batteries load tested by your authorized Provider.
- You may also perform the load test yourself. Battery load testers are available at most automotive parts stores.
- Follow the directions supplied with the load tester.
- See III. “Batteries and Charging” or “Product Specifications Sheet” for information about your Travel Scooter’s battery type.

### What if the battery condition meter dips way down and the motor surges or hesitates when I press the throttle control lever?

- Fully charge your Travel Scooter’s batteries. See III. “Batteries and Charging.”
- Have your authorized Provider load test each battery.
- Or, see the previous troubleshooting question for load testing the batteries yourself.

If you experience any problems with your Travel Scooter that you are not able to solve, immediately contact your authorized Provider for information, maintenance, and service.

## VIII. CARE AND MAINTENANCE

Your Travel Scooter requires a minimal amount of care and maintenance. If you do not feel confident in your ability to perform the maintenance listed below, you may schedule inspection and maintenance at your authorized Provider. The following areas require periodic inspection and/or care and maintenance.

### TIRES

Regularly inspect your Travel Scooter's tires for signs of damage or wear.

### WHEEL REPLACEMENT

Your Travel Scooter is equipped with solid tire inserts. If you have a damaged or worn tire, the entire wheel must be replaced. Contact your authorized Provider for information regarding replacement wheels for your Travel Scooter.

**WARNING! Wheels on your Travel Scooter should only be serviced/replaced by a qualified technician.**



**WARNING! Be sure that the key is removed from the key switch and the scooter is not in freewheel mode before performing this procedure.**

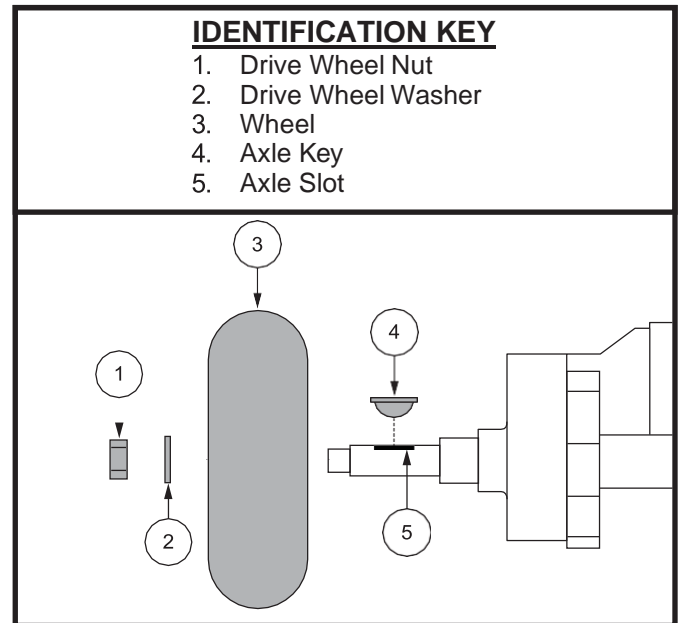

Figure 35. Wheel Replacement

Follow these easy steps for a quick and safe repair for solid tires:

1. Remove the key from the key switch and ensure your Travel Scooter is not in freewheel mode.
2. Elevate the side of the Travel Scooter of which you are removing the tire. Place wooden blocks under the frame to elevate the Travel Scooter.
3. Remove the drive wheel nut and washer from the axle. **See figure 35.**
4. Pull the wheel off the axle.
5. Slide the new wheel onto the axle. Make sure the the axle key is in the axle slot.



**WARNING! Ensure that the axle key is properly installed into the axle slot when mounting the wheel. If not installed securely, the braking system is disengaged which may cause personal injury and/or product damage may result.**

6. Reinstall the washer and drive wheel nut onto the axle and tighten.



**WARNING! Make sure that both the nut and washer are reinstalled and tightened properly.**

7. Remove the blocks from beneath the Travel Scooter.

### EXTERIOR SURFACES

Bumpers, tires, and trim can benefit from an occasional application of a rubber or vinyl conditioner.



**WARNING! Do not use a rubber or vinyl conditioner on the Travel Scooter's vinyl seat or tire tread. They will become dangerously slippery.**

### CLEANING AND DISINFECTION

- Use a damp cloth and mild, non-abrasive cleanser to clean the plastic and metal parts of your Travel Scooter. Avoid using products that may scratch the surface of your Travel Scooter.
- If necessary, clean your product with an approved disinfectant. Make sure the disinfectant is safe for use on your product before application.

## VIII. CARE AND MAINTENANCE



**WARNING!** Follow all safety instructions for the proper use of the disinfectant and/or cleaning agent before applying it to your product. Failure to comply may result in skin irritation or premature deterioration of upholstery and/or Travel Scooter finishes.

### BATTERY TERMINAL CONNECTIONS

Make certain that the terminal connections remain tight and are not corroded.

### WIRING HARNESES

- Regularly check all wiring connections.
- Regularly check all wiring insulation, including the charger power cord, for wear or damage.
- Have your authorized Provider repair or replace any damaged connector, connection, or insulation that you find before using your Travel Scooter again.



**PROHIBITED!** Even though the Travel Scooter has passed the necessary testing requirements for ingress of liquids, you should keep electrical connections away from sources of dampness, including direct exposure to water or bodily fluids and incontinence. Check electrical components frequently for signs of corrosion and replace as necessary.



**WARNING!** Do not pull on electrical harnesses directly to detach them from the scooter. Always grasp the connector itself when disconnecting the harness to prevent wire damage.

### DAILY CHECKS

- With the power turned off, check the throttle. Make sure it is not bent or damaged and that it returns to the neutral position when you release it. Do not try to repair it. See your authorized provider if there is a problem.
- Visually inspect the tiller cable. Make sure that it is not frayed, cut, or has any wires exposed. See your authorized provider if there is a problem.
- Check for flat spots on solid tires. Flat spots could adversely affect stability.
- Inspect the armrests for loose hardware, stress points, or damage. See your authorized provider if there is a problem.
- Check the brakes. This test should be carried out on a level surface with at least 3 feet (1 meter) of clearance around your scooter.

#### To check the brakes:

1. Turn on the power and turn down the speed level of your Travel Scooter.
2. After one second, check the battery condition meter. Make sure that it remains on.
3. Slowly pull the throttle forward until you hear the electric brakes click. Immediately release the throttle. You must be able to hear the electrical brake operating within a few seconds of throttle movement. Repeat this test by pulling the throttle in the opposite direction.

### WEEKLY CHECKS

- Inspect the controller and charger connectors for corrosion. Contact your authorized provider if necessary.
- Check for proper tire inflation, if equipped with pneumatic tires. If a tire does not hold air, contact your authorized provider for replacement of the tube.

### MONTHLY CHECKS

- Check that the anti-tip wheels do not rub the ground when you operate the Travel Scooter.
- Check for extreme wear on the anti-tip wheels. Replace them as necessary.
- Check for tire wear. See your authorized provider for repair.
- Keep you Travel Scooter clean and free of foreign material, such as mud, dirt, hair, food, drink, etc.

## VIII. CARE AND MAINTENANCE

### YEARLY CHECKS

Take your Travel Scooter to your authorized Provider for yearly maintenance, especially if you use your Travel Scooter on a daily basis. This helps ensure that your Travel Scooter is functioning properly and helps prevent future complications.

### ABS PLASTIC SHROUDS

If your Travel Scooter has a body shroud with a **glossy finish**, the body shroud has been sprayed with a clear sealant coating. You can apply a light coat of car wax to help it retain its high-gloss appearance. If your Travel Scooter has a body shroud with a **matte finish**, use **ONLY** products developed for matte-finish paint. Do not use wax, detail spray, ArmorAll®, or any product made for glossy paint.



**WARNING! Carefully choose the correct product to protect the finish of your Travel Scooter's shroud(s). ONLY products developed for matte-finish paint should be used on shrouds with a matte finish. Failure to follow this warning may result in damage to the shroud's matte paint finish.**

### AXLE BEARINGS AND THE MOTOR/TRANSAXLE ASSEMBLY

These items are all lubricated, sealed, and require no subsequent lubrication.

### CONSOLE, CHARGER AND REAR ELECTRONICS

- Keep these areas free of moisture.
- Allow these areas to dry thoroughly if they have been exposed to moisture before operating your Travel Scooter again.

### NYLON LOCK NUT REPLACEMENT

Any nylon insert lock nut removed during the periodic maintenance, assembly, or disassembly of the Travel Scooter must be replaced with a new nut. Nylon insert lock nuts should not be reused as it may cause damage to the nylon insert, resulting in a less secure fit. Replacement nylon insert lock nuts are available at local hardware stores or through your authorized Provider.

### STORING YOUR TRAVEL SCOOTER

If you plan on not using your Travel Scooter for an extended period of time, it is best to:

- Fully charge its batteries prior to storage.
- Remove the battery pack from the Travel Scooter.
- Store your Travel Scooter in a warm, dry environment.
- Avoid storing your Travel Scooter where it will be exposed to temperature extremes.
- Recommended storage temperature: -40°F/-40°C to 149°F/65°C.

Batteries that are regularly and deeply discharged, infrequently charged, stored in extreme temperatures, or stored without a full charge may be permanently damaged, causing unreliable performance and limited service life. It is recommended that you charge the Travel Scooter batteries periodically throughout periods of prolonged storage to ensure proper performance.



**WARNING! Always protect batteries from freezing temperatures and never charge a frozen battery. Charging a frozen battery can result in damage to the battery.**

For prolonged storage, you may wish to place several boards under the frame of your Travel Scooter to raise it off of the ground. This takes the weight off the tires and reduces the possibility of flat spots developing on the areas of the tires contacting the ground.

### DISPOSAL OF YOUR TRAVEL SCOOTER

Your Travel Scooter must be disposed of according to applicable local and national statutory regulations. Contact your local waste disposal agency or authorized Provider for information on proper disposal of packaging, metal frame components, plastic components, electronics, batteries, neoprene, silicone, and polyurethane materials.

# NOTES

***Manufacturer:***

Suzhou Sweetrich Vehicle Industry Technology co., Ltd.  
No.68 XinFa Road, Suzhou  
Industrial Park, Jiangsu,  
China, 215123

***EU Representative:***

SWEMO GmbH  
Adenauerstrasse 6  
52146, Wuerselen,  
Germany

***UK Distributor:***

Pride Mobility Ltd  
32 Wedgwood Road  
Bicester, Oxfordshire  
OX26 4UL

[www.pride-mobility.co.uk](http://www.pride-mobility.co.uk)

SN: