

Invacare® Action® Ampla™

en Medium active wheelchair
User Manual



This manual **MUST** be given to the user of the product.
BEFORE using this product, this manual **MUST** be read and saved for
future reference.



Yes, you can.®

© 2019 Invacare Corporation

All rights reserved. Reproduction, duplication or modification in whole or in part is prohibited without prior written permission from Invacare. Trademarks are identified by ™ and ®. All trademarks are owned by or licensed to Invacare Corporation or its subsidiaries unless otherwise noted.

Making Life's Experiences Possible is a registered trademark in the U.S.A.

Contents

1 General	4
1.1 Introduction	4
1.2 Symbols in this Document	4
1.3 Warranty Information	4
1.4 Compliance	5
1.4.1 Product-specific standards	5
1.5 Service Life	5
1.6 Limitation of Liability	5
2 Safety	6
2.1 Safety information	6
2.2 Safety devices	7
2.3 Labels and symbols on the product	7
3 Product Overview	9
3.1 Intended use	9
3.2 Main parts of the wheelchair	10
4 Setup	13
4.1 Safety information	13
5 Usage	14
5.1 Safety information	14
5.2 Braking during use	14
5.3 Getting in and out of the wheelchair	15
5.4 Driving and steering the wheelchair	16
5.5 Negotiating steps and kerbs	17
5.6 Negotiating ramps and slopes	18
5.7 Stability and balance when seated	20
5.8 Parking brakes	21
5.9 Backrest	21
5.10 Leg rests	22
5.11 Transfer help	23
5.12 Antitipper	24
5.13 Seat cushion	25

6 Options	26
6.1 Posture belt	26
6.2 Push bar	28
6.3 Drip stand	28
6.4 Assistant brakes	30
6.5 Cane holder	30
6.6 Oxygen bottle holder	31
7 Transport	32
7.1 Safety information	32
7.2 Transportation Bearing	32
7.3 Removing and installing the rear wheels	33
7.4 Lifting the wheelchair	34
7.5 Transporting the occupied wheelchair in a vehicle	34
8 Maintenance	40
8.1 Safety information	40
8.2 Maintenance Schedule	40
8.3 Cleaning and Disinfection	42
8.3.1 General Safety Information	42
8.3.2 Cleaning Intervals	43
8.3.3 Cleaning	43
8.3.4 Disinfection	43
9 After Use	44
9.1 Storage	44
9.2 Reconditioning	44
9.3 Disposal	44
10 Troubleshooting	45
10.1 Safety information	45
10.2 Identifying and repairing faults	46
11 Technical Data	47
11.1 Dimensions and weight	47
11.2 Materials	48
11.3 Environmental conditions	49

1 General

1.1 Introduction

This user manual contains important information about the handling of the product. To ensure safety when using the product, read the user manual carefully and follow the safety instructions.

Note that there may be sections in this document, which are not relevant to your product, since this document applies to all available models (on the date of printing). If not otherwise stated, each section in this document refers to all models of the product.

The models and configurations available in your country can be found in the country-specific sales documents.

Invacare reserves the right to alter product specifications without further notice.

Before reading this document, make sure you have the latest version. You find the latest version as a PDF on the Invacare website.

If you find that the font size in the printed document is difficult to read, you can download the PDF version from the website. The PDF can then be scaled on screen to a font size that is more comfortable for you.

For more information about the product, for example product safety notices and product recalls, contact your Invacare distributor. See addresses at the end of this document.

In case of a serious incident with the product, you should inform the manufacturer and the competent authority in your country.

1.2 Symbols in this Document

Symbols and signal words are used in this document and apply to hazards or unsafe practices which could result in personal injury or property damage. See the information below for definitions of the signal words.



WARNING

Indicates a hazardous situation that could result in serious injury or death if it is not avoided.



CAUTION

Indicates a hazardous situation that could result in minor or slight injury if it is not avoided.



IMPORTANT

Indicates a hazardous situation that could result in damage to property if it is not avoided.



Tips and Recommendations

Gives useful tips, recommendations and information for efficient, trouble-free use.

1.3 Warranty Information

We provide a manufacturer's warranty for the product in accordance with our General Terms and Conditions of Business in the respective countries.

Warranty claims can only be made through the provider from whom the product was obtained.

1.4 Compliance

Quality is fundamental to the company's operation, working within the disciplines of ISO 13485.

This product features the CE mark, in compliance with the Medical Device Regulation 2017/745 Class I. The launch date of this product is stated in the CE declaration of conformity.

We are continuously working towards ensuring that the company's impact on the environment, locally and globally, is reduced to a minimum.

We only use REACH compliant materials and components.

1.4.1 Product-specific standards

The wheelchair has been tested in accordance with EN 12183. It includes testing for flammability.

For further information about local standards and regulations, contact your local Invacare representative. See addresses at the end of this document.

1.5 Service Life

The expected service life of this product is five years when used daily and in accordance with the safety instructions, maintenance intervals and correct use, stated in this manual. The effective service life can vary according to frequency and intensity of use.

1.6 Limitation of Liability

Invacare accepts no liability for damage arising from:

- Non-compliance with the user manual

- Incorrect use
- Natural wear and tear
- Incorrect assembly or set-up by the purchaser or a third party
- Technical modifications
- Unauthorised modifications and/or use of unsuitable spare parts

2 Safety

2.1 Safety information

This section contains important safety information for the protection of the wheelchair user and assistant and for safe, trouble-free use of the wheelchair.

Invacare presumes a healthcare professional has made an individual assessment of the user to determine his risk level or therapy requirements. Providers and carers have assessed that the product gives the required support and that its adjustments are appropriate for the user. Carer and user have been appropriately instructed by a healthcare professional on how to use the product correctly and safely.

**WARNING!****Risk of accidents and serious injury**

Accidents with resulting serious injury can occur if the wheelchair is improperly adjusted.

- Wheelchair adjustments must always be carried out by a qualified technician.

**WARNING!****Risk due to driving style being unsuitable for the conditions**

There is a risk of skidding on wet ground, gravel or uneven terrain.

- Always adjust your speed and driving style to the conditions (weather, surface, individual ability, etc.).

**WARNING!****Risk of injury**

In a collision you could sustain injury to parts of your body that extend beyond the wheelchair (e.g. feet or hands).

- Avoid an unbraked collision.
- Never drive into an object head-on.
- Drive carefully through narrow passages.

**WARNING!****Risk due to wheelchair being out of control**

At high speed you could lose control of your wheelchair and overturn.

- Never exceed a speed of 7 km/h.
- Avoid collisions in general.

**CAUTION!****Risk of burning**

The wheelchair components can heat up when exposed to external sources of heat.

- Do not expose the wheelchair to strong sunlight before use.
- Before usage, check all components that come into contact with your skin for their temperature.

**CAUTION!****Risk of getting fingers caught**

There is always a risk of getting, e.g. fingers or arms, caught in the moving parts of the wheelchair.

- Make sure when activating the folding or insertion mechanisms of moving parts, such as the removable axle of the rear wheel or folding backrest that nothing becomes caught.

**CAUTION!****Risk of Injury**

Non-original or wrong parts may affect the function and safety of the product.

- Only use original parts for the product in use.
- Due to regional differences, refer to your local Invacare catalog or website for available options or contact your Invacare distributor. See addresses at the end of this document.

**IMPORTANT!**

When combining this product with another product, the restrictions of both products apply for the combination. E.g. the maximum user weight of one product in the combination may be lower.

- Only use combinations allowed by Invacare. Contact your Invacare distributor for information.
- Before use, read the user manual of each product and check the restrictions.

2.2 Safety devices

**WARNING!****Risk of accidents**

Safety devices that are incorrectly set or no longer working (wheel locks, antitippers, transportation kit, postural belt) can cause accidents.

- Always check that the safety devices are working before you use the wheelchair and have them checked regularly by a qualified technician or your provider.

The functions of the safety devices are described in chapter 3.2 *Main parts of the wheelchair*, page 10.

2.3 Labels and symbols on the product

Identification label

The identification label is attached to the frame of your wheelchair and gives the following information:

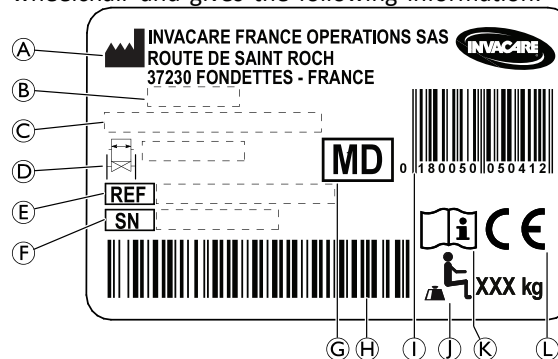

Ⓐ	Manufacturer's address
Ⓑ	Date of manufacture
Ⓒ	Product description
Ⓓ	Seat width
Ⓔ	Reference number
Ⓕ	Serial number
Ⓖ	Medical device
Ⓗ	Serial number barcode
Ⓘ	EAN/HMI barcode
Ⓝ	Maximum user weight
Ⓚ	Read user manual
Ⓛ	European conformity

Snap hook symbol

	<p>Tie-down positions where the restraint system straps must be placed in case of transporting the occupied wheelchair in a motor vehicle, refer to <i>7.5 Transporting the occupied wheelchair in a vehicle, page 34</i>.</p> <p>This symbol is only attached to the wheelchair when it is ordered with the transportation kit option.</p>
---	---

	<p>WARNING Symbol</p> <p>This wheelchair is not configured for passenger transport in a motor vehicle. This symbol is attached to the frame close to the identification label. Only applicable when the transportation kit is not installed.</p>
--	---

Transportation bearing label

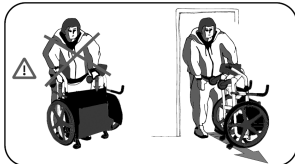
	<p>Label for the correct usage of the transportation bearing, see <i>7.2 Transportation Bearing, page 32</i>. The label is attached to the front crossbar of the frame.</p>
--	---

3 Product Overview

3.1 Intended use

This medium active wheelchair is intended to provide mobility to overweight persons with limited walking ability.

The intended user is the person sitting in the wheelchair or an assistant. The user must physically and mentally be able to use the wheelchair safely (e.g. to propel, steer, brake).

The product is intended for institutional use or private household use. The wheelchair may be used indoors and outdoors on level ground and accessible terrain.

The weight of the wheelchair occupant must not exceed the maximum user weight as stated in the Technical Data section and on the identification label.

Indications

Adult overweight persons ages 15 and up (adolescents and adults) with mobility difficulties and restricted walking ability who have:

- Pain in the musculoskeletal system when walking or standing.
- Restricted lung capacity.

Contraindications

There are no known contraindications.



This medium active wheelchair needs to be prescribed and fit to your specific health condition.

3.2 Main parts of the wheelchair

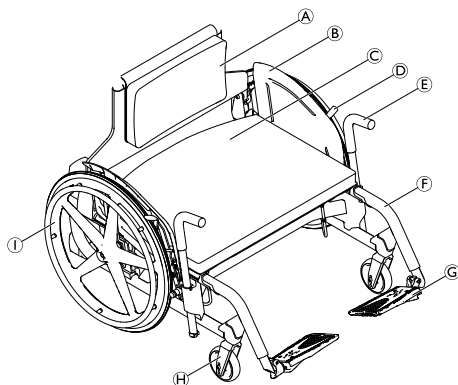

Pos.	Item	Description/Usage/Adjustments see...
Ⓐ	Backrest with cushion	5.9 Backrest, page 21
Ⓑ	Clothes-guard	—
Ⓒ	Seat with seat cushion	5.13 Seat cushion, page 25
Ⓓ	Parking brakes	5.8 Parking brakes, page 21
Ⓔ	Transfer help	5.11 Transfer help, page 23
Ⓕ	Leg rest	5.10 Leg rests, page 22
Ⓖ	Foot plate	—
Ⓗ	Castor fork with castor wheel	—
Ⓘ	Rear wheel with handrim	7.3 Removing and installing the rear wheels, page 33

Short description

Invacare Action Ampla is a medium active wheelchair, optimised for bariatric use. The wheelchair features two rear wheels, two front castors, upholstered seat and backrest, parking brakes, detachable legrests, transfer helps and a rigid frame.

 The equipment of your wheelchair may differ from the image as each wheelchair is manufactured individually to the specifications in the order.

Options overview

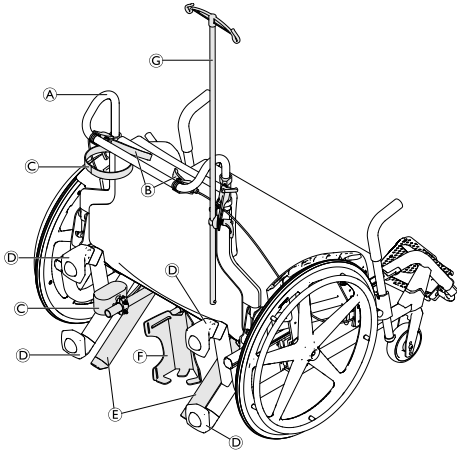

Pos.	Item	Description/Usage/Adjustments see...
Ⓐ	Push bar	6.2 Push bar, page 28
Ⓑ	Assistant brakes	6.4 Assistant brakes, page 30
Ⓒ	Cane holder	6.5 Cane holder, page 30
Ⓓ	Transportation bearing	7.2 Transportation Bearing, page 32

Pos.	Item	Description/Usage/Adjustments see...
Ⓔ	Antitippers	<i>5.12 Antitipper, page 24</i>
Ⓕ	Oxygen bottle holder	<i>6.6 Oxygen bottle holder, page 31</i>
Ⓖ	Drip stand	<i>6.3 Drip stand, page 28</i>

4 Setup

4.1 Safety information

**CAUTION!****Risk of injury**

- Before using the wheelchair, check its general condition and its main functions, 8.2 *Maintenance Schedule, page 40.*

Your provider will supply your wheelchair ready for use. Your provider will explain the main functions and ensure that the wheelchair meets your needs and requirements. When you receive the wheelchair, the rear wheel axle is always mounted in the foremost position. To make the wheelchair more stable, the axle can be set to the rear by two possible positions.

Adjustments of the axle position and the castors must be carried out by a qualified technician.

5 Usage

5.1 Safety information



WARNING!

Risk of falling out of the wheelchair

When using small castors the wheelchair could get stuck at kerbs or in floor grooves.

- Make sure that the castors are suitable for the surface you are driving on.



WARNING!

Risk of hazardous situations

- Do not operate the wheelchair on public roads.



CAUTION!

Risk of crushing

There may be a very small gap between the rear wheel and the mudguard with the risk that you could trap your fingers.

- Ensure that you always propel your wheelchair using the handrims only.



CAUTION!

Risk of accidents

The wheelchair is designed to be used only by one person.

- Make sure that only one person is sitting in the wheelchair.



IMPORTANT!

Risk of damage to the product

- Do not use the wheelchair as a weight training apparatus.

Theft and metal detection systems

In seldom cases the materials used in the wheelchair may activate theft and metal detection systems.

5.2 Braking during use

Whilst you are moving, you brake by transferring force to the handrims with your hands.



WARNING!

Risk of overturning

If you apply the parking brakes while you are moving, the direction of movement can become uncontrollable and the wheelchair may stop suddenly, which can lead to a collision or to you falling out.

- Never apply the parking brakes while you are moving.



WARNING!

Risk of falling out of the wheelchair

If the wheelchair is rapidly decelerated by an assistant pulling at the push handles, the user may fall out of the wheelchair.

- Always apply the posture belt if present.
- Make sure your assistant is qualified in transferring occupied wheelchairs.

**CAUTION!****Risk of burning your hands**

If you brake for a long time, a lot of frictional heat is produced at the handrims.

- Wear suitable gloves.

1. Hold the handrims and press evenly with both hands until the wheelchair stops.

Braking with an assistant

With an assistant's brake an assistant can brake the wheelchair while it is moving.

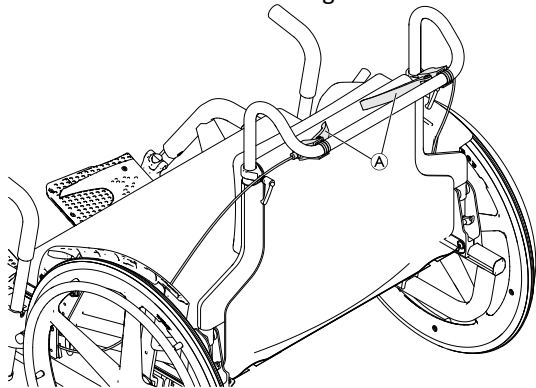

1. To brake, pull the brake lever (A) on the push bar.

5.3 Getting in and out of the wheelchair**WARNING!****Risk of overturning**

There is a high risk of overturning during the transfer.

- Only get in and out without assistance if you are physically able to do so.
- When transferring, position yourself as far back as possible in the seat. This will prevent damaged upholstery and the possibility of the wheelchair tipping forward.
- Make sure that both castors are facing straight to the front.

**WARNING!****Risk of overturning**

The wheelchair could tip forwards if you stand on the foot plate.

- Never stand on the foot plate when getting in and out.

**CAUTION!**

If you release or damage the brakes the wheelchair could roll away out of control.

- Do not support yourself on the brakes when getting in and out.

**IMPORTANT!**

The clothes-guards could become damaged.

- Never sit on the clothes-guards when getting in and out.

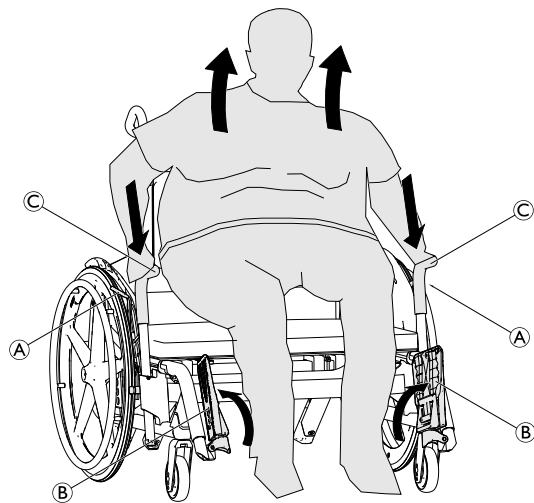

1. Engage both wheel locks (A).
2. Flip up the foot plates (B) or swing the legrests outwards.
3. Place both feet securely on the ground.
4. Support yourself with both hands on the transfer helps (C).



Make sure that the handles of the transfer helps are facing forwards. This will reduce the effort of getting in and out of the wheelchair.

5. Slowly get up from the wheelchair.

5.4 Driving and steering the wheelchair

You drive and steer the wheelchair using the handrims.



WARNING!

Risk of tipping

The wheelchair can tip backwards if it is not fitted with antitippers or transportation bearings.

- Make sure that antitippers or transportation bearings are installed before driving the wheelchair.



WARNING!

Risk of tipping

The wheelchair can tip forwards.

- When setting up your wheelchair, test its behavior in terms of tipping forward and adjust your driving style accordingly.



CAUTION!

A heavy load hanging on the backrest can affect the wheelchair's centre of gravity.

- Change your driving style accordingly.

Finding the tipping point with an assistant



To show the user the tipping point, the wheelchair can be tilted backwards by an assistant using the push bar.

5.5 Negotiating steps and kerbs



CAUTION!

Risk of accidents and damage to the wheelchair

When crossing steps or kerbs the antitipper or the transportation bearing may get caught and the wheelchair may tip over or components may get damaged.

- Do not negotiate steps and kerbs when the antitipper or the transportation bearing is installed.

Without an assistant



WARNING!

Risk of overturning

When negotiating steps you could lose your balance and tip the wheelchair over.

- Assess the crossing of the obstacle correctly.
If you are unsure of crossing the obstacle safely, get up from the wheelchair, move it by hand over the obstacle and then continue the journey.

With an assistant





WARNING!

Risk of injury to the assistant and damage to the wheelchair

Tilting the chair with a heavy user can hurt the assistant's back and damage the chair.

- Do not tilt the chair when the user weight is more than 150 kg.
- Make sure to be able to safely control the wheelchair with a heavy user before performing a tilting manoeuvre.

Going down a step

1. Move the wheelchair right up to the kerb and hold the handrims.
2. The assistant should hold the push bar and tilt the wheelchair backwards so that the castors lift off the ground.
3. The assistant should then hold the wheelchair in this position, push it carefully down the step and then tilt it forwards until the castors are back on the ground.

Going up a step



WARNING!

Risk of serious injuries

Going up steps and kerbs frequently can result in earlier than expected fatigue break of the wheelchair backrest. The user might fall out of the wheelchair.

1. Move the wheelchair backwards until the rear wheels touch the kerb.
2. The assistant should tilt the wheelchair using both push handles so that the castors lift off the ground, then pull the rear wheels over the kerb until the castors can be placed back on the ground.

5.6 Negotiating ramps and slopes



WARNING!

Risk due to wheelchair being out of control

When negotiating slopes or gradients your wheelchair could tip backwards, forwards or sideways.

- Always have an assistant behind the wheelchair when approaching long slopes.
- Avoid lateral slopes.
- Avoid slopes of more than 7°.
- Avoid jerking when changing direction on a slope.



CAUTION!

Your wheelchair could run away even on slightly sloping ground if you do not control it using the handrims.

- Use the parking brakes if your wheelchair is stationary on sloping ground.

Going up slopes

To go up a slope, you must create some momentum, keep up the momentum and control the direction at the same time.

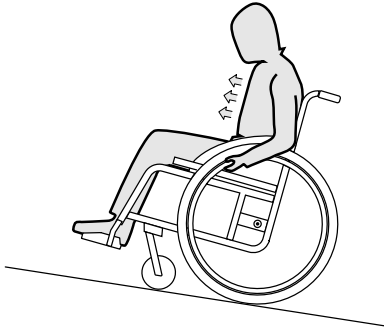

1. Bend your upper body forwards and propel the wheelchair with quick, powerful strokes on both handrims.

Going down slopes

When going down slopes, it is important to control your direction and particularly your speed.

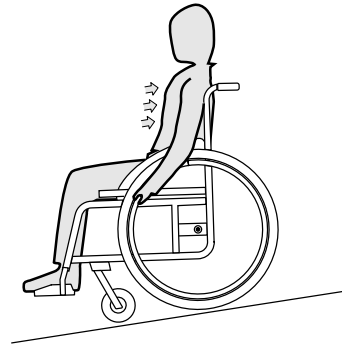

1. Lean back and carefully allow the handrims to run through your hands. You should be able to stop the wheelchair at any time by gripping the handrims.



CAUTION!

Risk of burning your hands

If you brake for a long time, a lot of frictional heat is produced at the handrims.

– Wear suitable gloves.

5.7 Stability and balance when seated

Some everyday activities and actions require you to lean forwards, sideways or backwards out of the wheelchair. This has a major effect on the wheelchair's stability. To keep your balance at all times, proceed as follows:

Leaning forwards



WARNING! **Risk of falling out**

If you lean forwards out of the wheelchair you could fall out of it.

- Never bend too far forwards and do not shift forwards in your seat to reach an object.
- Do not bend forwards between your knees to pick up something off the floor.

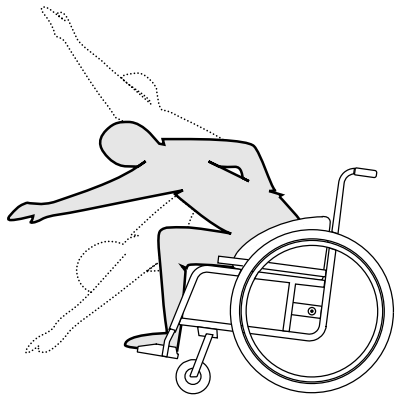

1. Point the front wheels forwards. (To do this, move your wheelchair forwards slightly then back again.)
2. Apply both parking brakes.
3. When leaning forwards your upper body must remain over the front wheels.

Reaching backwards



WARNING! **Risk of falling out**

If you lean too far backwards you could tip your wheelchair over.

- Do not lean out over the backrest.
- Use an antitipper device.

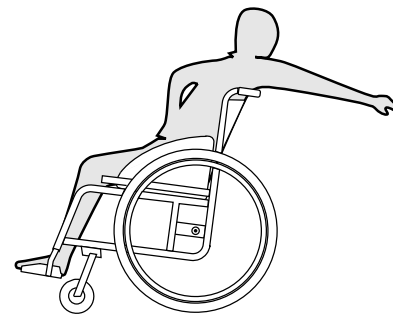

1. Point the front wheels forwards. (To do this, move your wheelchair forwards slightly then back again.)
2. Do not apply the parking brakes.
3. When reaching backwards do not reach so far that you have to change your sitting position.

5.8 Parking brakes

The parking brakes are used to immobilise the wheelchair when it is stationary to prevent it from rolling away.



WARNING!

Risk of overturning if you brake sharply

If you engage the parking brakes while you are moving, the direction of movement can become uncontrollable and the wheelchair may stop suddenly, which can lead to a collision or to you falling out.

- Never engage the parking brakes while you are moving.

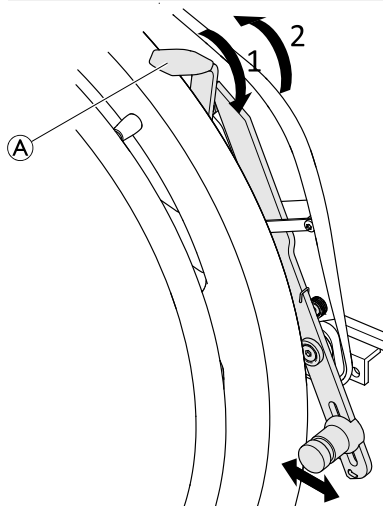

1. To engage the parking brake, push the lever **A** forwards as far as possible.
2. To disengage the parking brake, pull the lever backwards.

5.9 Backrest

The backrest can be folded.

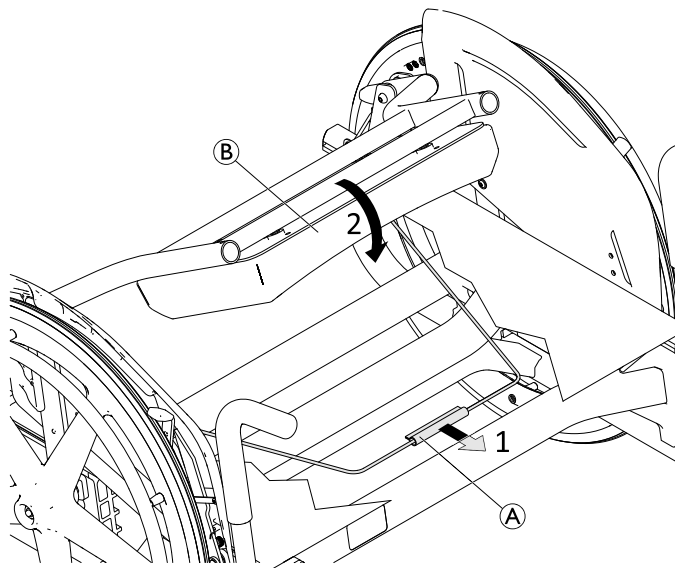

Folding down the backrest

1. To fold down the backrest, grip the wire **A** under the seat of the wheelchair and pull it forwards.
2. At the same time, push the backrest **B** forwards until it engages with an audible “click”.

Folding up the backrest

1. To fold up the backrest, grip the upper edge of the backrest and fold it upwards until it engages with an audible “click”.



IMPORTANT!

Risk of damage to the wheelchair

- Do not sit on the wheelchair, when the backrest is folded down.

Removing the backrest cushion



The backrest cushion is attached to the backrest by means of hook-and-loop fasteners and can be easily removed for cleaning purposes.



CAUTION!

Sitting on the wheelchair without a backrest cushion installed can lead to incorrect and uncomfortable sitting position.

- Do not sit in the wheelchair without the backrest cushion installed.

5.10 Leg rests

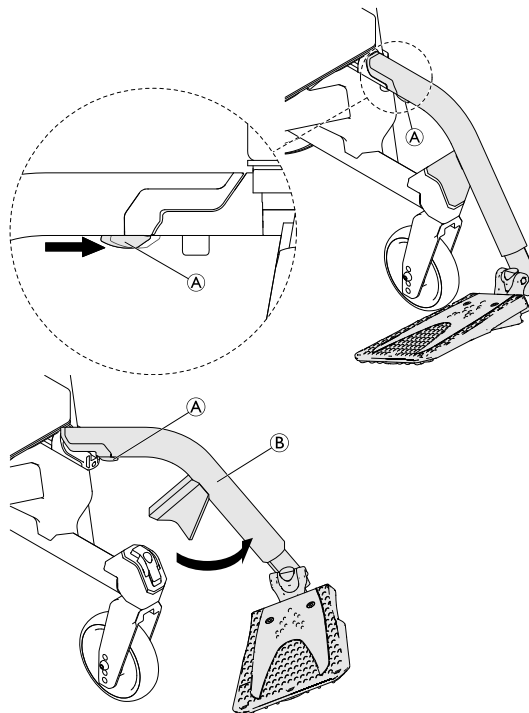

Swinging outwards

1. Activate the release lever (A), slightly lift the leg rest (B) and swing it to the outside.

Swinging forwards

1. Swing the leg rest forwards until it engages.

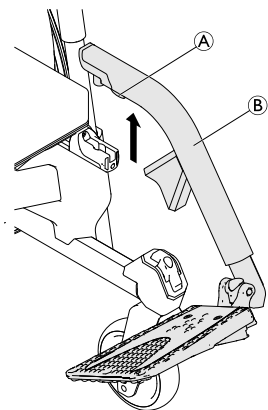

Unhinging

1. Activate the release lever (A).
2. Pull the leg rest (B) upwards.

Hinging

1. Hinge the leg rest on the front of the frame and swing it forwards until it engages with an audible click.

5.11 Transfer help

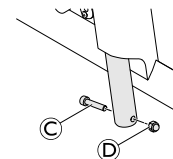
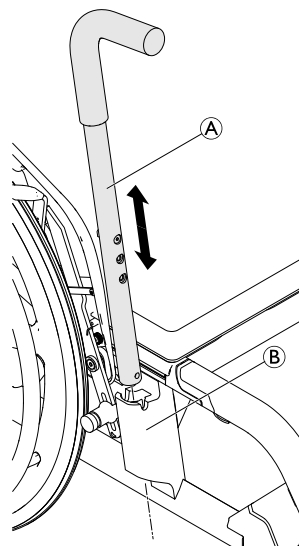

Removing/Installing

1. Remove the bolt (C) and the nut (D).
2. Remove the transfer help (A) by simply pulling it out of the holder (B).
3. Reinsert the transfer help by pushing it completely into the holder.
4. Reinsert the bolt and secure with the nut.

5.12 Antitipper

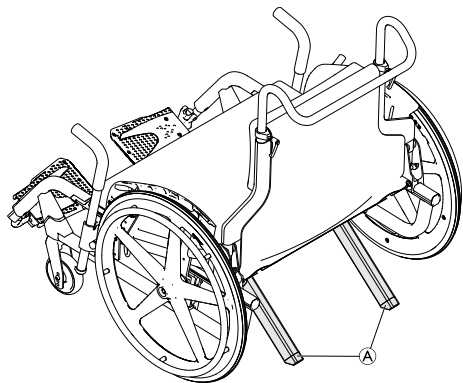

Antitippers **A** prevent the wheelchair from tipping backwards. Antitippers are pre-installed and available as an option.



WARNING!

Risk of injury

Antitippers that are incorrectly set or no longer working can lead to overturning.

- Always check that the antitippers are securely installed before using the wheelchair. Have them reinstalled or readjusted by a qualified technician only, when required.



WARNING!

Risk of overturning

On uneven or soft ground, the antitippers can sink into potholes or directly into the ground, thereby curtailing or eliminating their safety function.

- Only use antitippers when travelling on even and firm ground.



WARNING!

Risk of injury and damage to the wheelchair

The antitipper or transportation bearing can brake due to material fatigue when stepping on it and exerting force.

- Do not use the antitipper or transportation bearing as a tipping aid.



As an alternative to the antitippers a transportation bearing is available which already includes the anti-tip function, see *7.2 Transportation Bearing, page 32*.

5.13 Seat cushion

A suitable cushion is needed to provide an even pressure distribution on the seat.

**CAUTION!**

Adding a cushion to the seat will raise your height above the ground and can affect your stability in all directions. If a cushion is changed it may also change the user's stability.

- If the thickness of the cushion is changed or another cushion model is chosen, a complete set up of the wheelchair must be done by a qualified technician.



Remove the upper soft layer from the seat to prevent the seat cushion from slipping.

6 Options

6.1 Posture belt

The wheelchair can be equipped with a posture belt. It prevents the user from sliding downward in the wheelchair or from falling out of the wheelchair. The posture belt is not a positioning device.



WARNING!

Risk of serious injury / strangulation

A loose belt can allow the user to slip down and create a risk of strangulation.

- The posture belt should be mounted by a qualified technician and fitted by the responsible prescriber.
- Always make sure that the posture belt is tightly fitted across the lower pelvis.
- Each time the posture belt is used, check if it fits properly. Changing the seat and/or backrest angle, the cushion and even your clothes influence the fit of the belt.

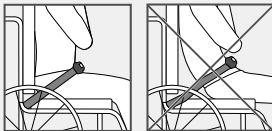

WARNING!

Risk of serious injury during transport

In a vehicle, a user in his wheelchair must be secured by a safety belt (3-point belt). A posture belt only is not sufficient as a personal restraint device.

- Use the posture belt as a complement, but not as a substitute to the 3-point safety belt, when transporting the wheelchair user in a vehicle.

Closing and opening the posture belt

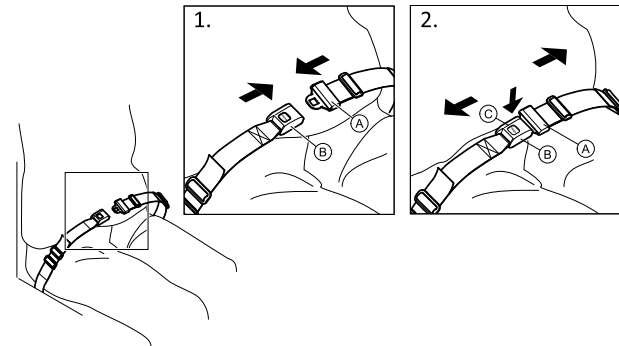

Ensure that you are sitting fully back in the seat and that the pelvis is as upright and symmetrical as possible.

1. To close, push the catch (A) into the buckle clasp (B).
2. To open, push the PRESS button (C) and pull the catch (A) out of the buckle clasp (B).

Adjusting the length

 The posture belt has the good length, when there's just sufficient space for a flat hand between body and belt.

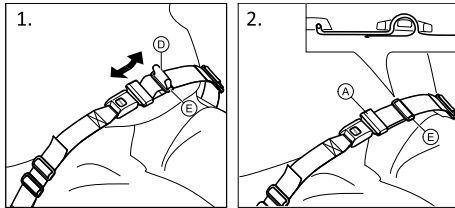

1. Shorten or extend the loop **D** as required.
2. Thread loop **D** through catch **A** and plastic buckle **E** until the loop is flat.

If this adjustment is not sufficient, it might be required to re-fit the posture belt at the fixations.

Fitting the posture belt at the fixations



CAUTION!

- Thread the belt loop through both plastic buckles to avoid the belt from loosening.
- Do the adjustments on both sides equally, so that the buckle clasp remains in a central position.
- Make sure that the belts do not get caught in the spokes of a rear wheel.

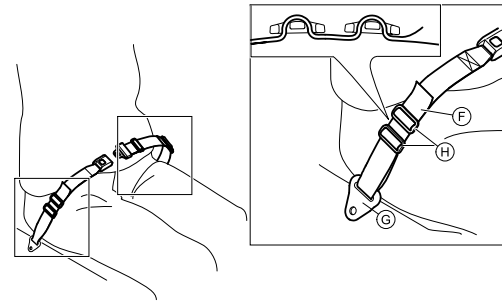

1. Thread the loop **F** through the fixation on the chair **G** and then through BOTH plastic buckles **H**.

6.2 Push bar

A push bar can optionally be installed.

An installed push bar is required for the following options:

- Assistant brake
- Drip stand

Installing/removing

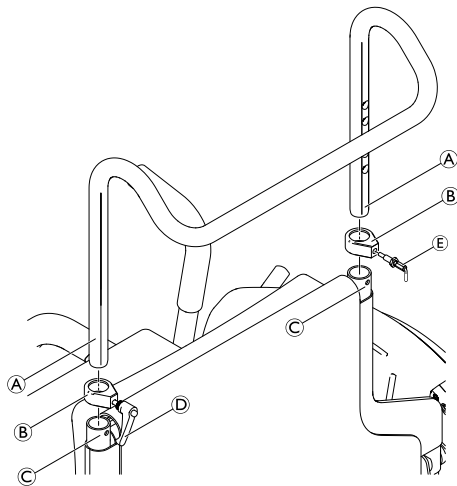

1. Place both clamping parts **B** on the ends of the backrest tubes **C**. Make sure that the holes of the clamping parts are aligned with the holes of the backrest tube ends.
2. Insert the push bar **A** into the backrest tubes.
3. Move the push bar to the required height and screw the quick release pin **E** into the clamping part. Let the pin engage to the nearest hole on the push bar.

4. Secure the push bar in the backrest tube on the other side by turning the lever **D** of the clamping part clockwise.
5. To remove the push bar reverse steps 3 to 1.

Adjusting the height

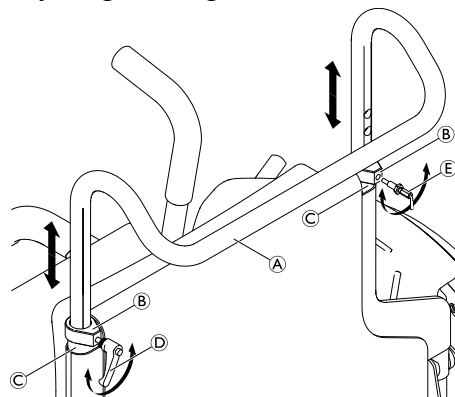

1. Loosen both clamping parts **B** by turning the lever **D** counterclockwise and disengaging the quick release pin **E** on the other side.
2. Move the push bar **A** to the required height and let the quick release pin engage into the nearest hole of the push bar.
3. Secure the push bar in the backrest tube on the other side by turning the lever **D** of the clamping part clockwise.

6.3 Drip stand

To install the drip stand the wheelchair has to be equipped with the push bar.

Installing

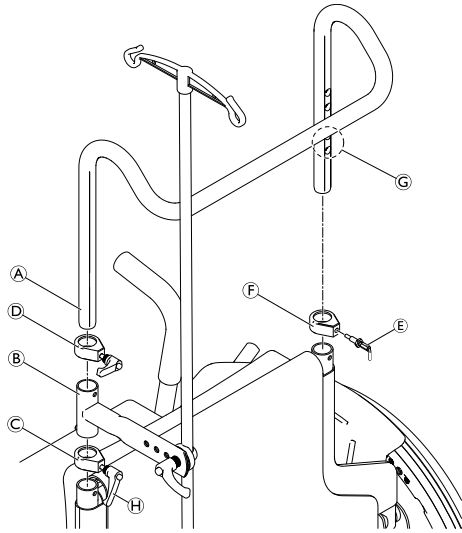

1. Loosen the clamping part **C** by turning the lever **H** counterclockwise.
2. Loosen the clamping part **F** by pulling the quick release pin **E**.
3. Remove the push bar **A**.
4. Position the drip stand support **B** on the clamping part **C**.
5. Position the clamping part **D** on the drip stand support.
6. Insert the push bar through the parts **D**, **B** and **C** into the frame tube (only through clamping part **F** on the other side).

7. Let the quick release pin **E** engage in one of the two lower holes **G** on the push bar.
8. Secure the push bar by turning the lever **H** and **D** clockwise.

Adjusting the height and angle

- i** The rod of the drip stand must always be placed in a vertical position, i.e. in a 90° angle to the ground, no matter the position of the backrest or the wheelchair.

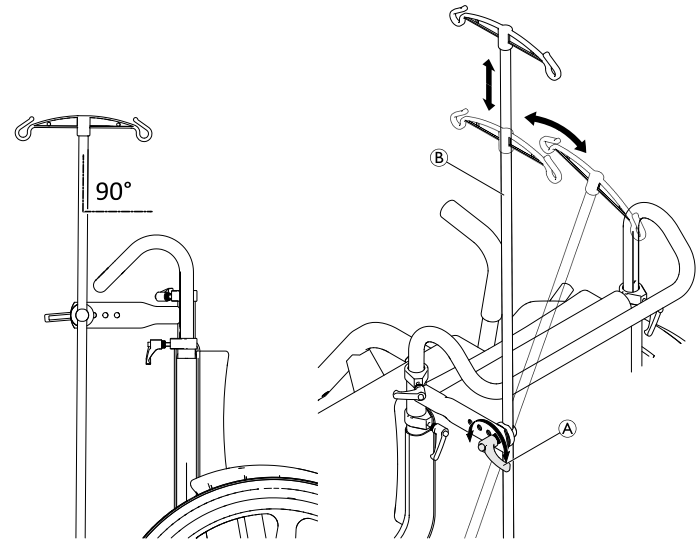

1. Loosen the lever (A).
2. Adjust the drip stand (B) to the desired height and correct the angle for vertical alignment (90° angle to the ground).
3. Re-tighten the lever (A).

! **IMPORTANT!**
Risk of damage to the drip stand
– Do not exceed the maximum load capacity of 2 x 2.5 kg.

6.4 Assistant brakes

Assistant brakes can optionally be installed to the push bar of the wheelchair.

The assistant brakes must be installed by your provider or a qualified technician.

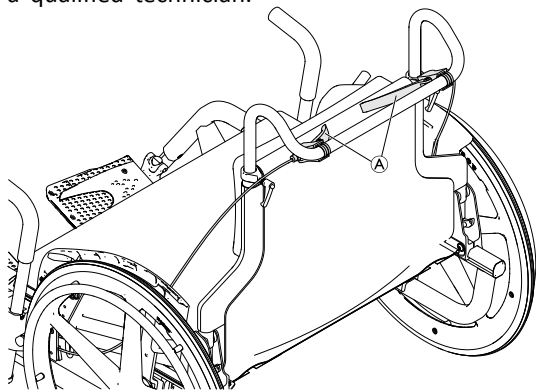

1. Pull and hold the brake levers (A) to engage the brakes.
2. To disengage the brakes release the brake levers.

6.5 Cane holder

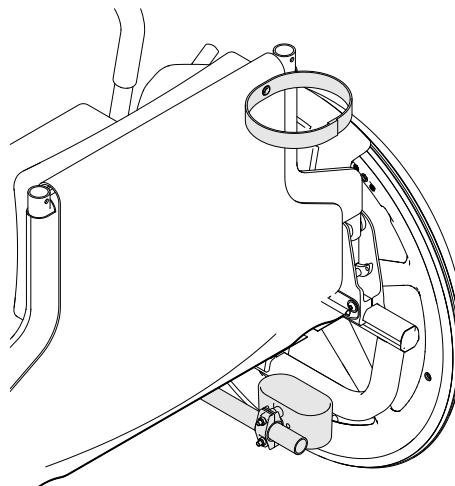

A cane holder can optionally be installed on the lower cross frame and the backrest of the wheelchair.

The cane holder must be installed by your provider or a qualified technician.

6.6 Oxygen bottle holder

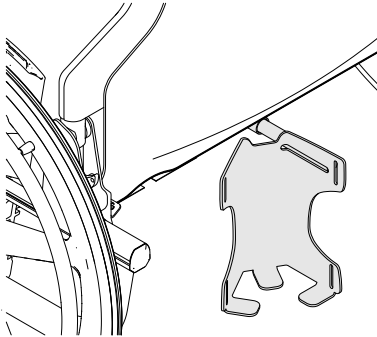

An oxygen bottle holder can optionally be installed on the wheelchair.

A mounting instruction is included in the scope of delivery when this option is chosen.

7 Transport

7.1 Safety information



WARNING!

Risk of injury if the wheelchair is not properly secured

In the event of an accident, braking manoeuvre, etc. you may suffer serious injuries from flying wheelchair parts.

- Always remove the rear wheels when transporting the wheelchair.
- Position the wheelchair on the transportation bearing, if installed, see *7.2 Transportation Bearing, page 32*.
- Firmly secure all wheelchair components in the means of transport to prevent them from coming loose during the journey.



IMPORTANT!

Excessive wear and abrasion could affect the strength of load-bearing parts.

- Do not pull your wheelchair across abrasive surfaces without the wheels fitted (e.g. pulling the frame over tarmac).

7.2 Transportation Bearing

The wheelchair can be equipped with a transportation bearing which decreases the dimension for easier transportation and storage.

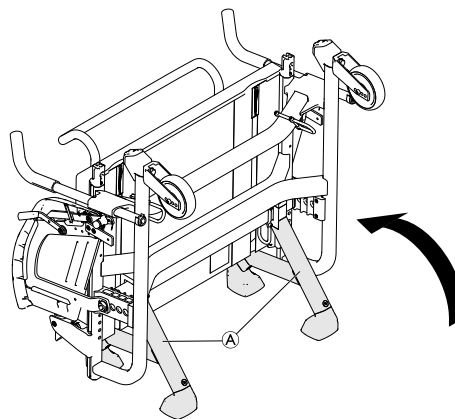

WARNING!

Risk of injury and damage to the wheelchair

The antitipper or transportation bearing can brake due to material fatigue when stepping on it and exerting force.

- Do not use the antitipper or transportation bearing as a tipping aid.

1. Fold the backrest against the seat until it engages with an audible “click”.
2. Raise the wheelchair and place it on the castors of the transportation bearing (A).

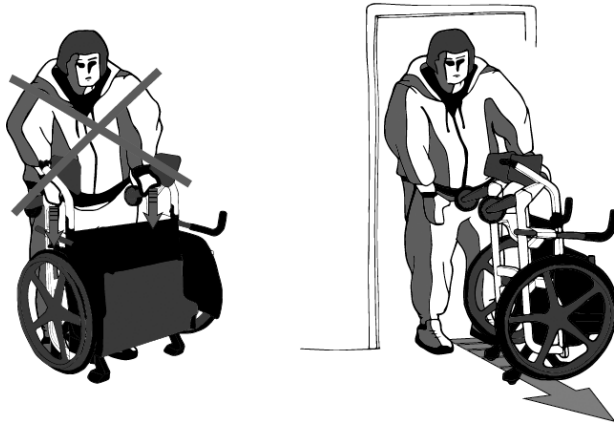

IMPORTANT!

The transportation bearing is exclusively intended to transfer the wheelchair through narrow door frames, entrances or similar.

- Do not support yourself with your body weight on the transportation bearing.
- Do not use the transportation bearing as a rollator.

7.3 Removing and installing the rear wheels



WARNING!

Risk of overturning

If the removable axle of a rear wheel is not fully engaged, the wheel can become loose during use. This can lead to overturning.

- Always ensure that the removable axles are fully engaged whenever you fit a wheel.

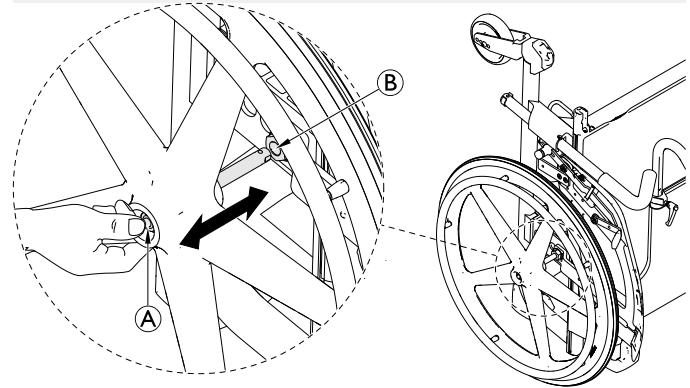

Removing the rear wheels

1. Disengage the parking brakes.
2. Fold down the backrest, see 5.9 *Backrest*, page 21.
3. Raise the wheelchair and tip it on the transportation bearing, see 7.2 *Transportation Bearing*, page 32.
4. Using your thumb, press the button **A** of the removable axle. Keep it pressed and pull the wheel out of the adapter sleeve **B**.

Installing the rear wheels

1. Hold the wheel at the wheel hub.
2. Using your thumb, press the button **(A)** of the removable axle and hold it down.
3. Push the axle into the adapter sleeve **(B)** up to the stop.
4. Release the removable axle button and make sure that the wheel is secure.
5. Tip the wheelchair on the rear wheels and castors.
6. Fold up the backrest.

7.4 Lifting the wheelchair



IMPORTANT!

- Never lift the wheelchair by removable parts (transfer help, footrests).
- Ensure the backrest posts are securely in place.

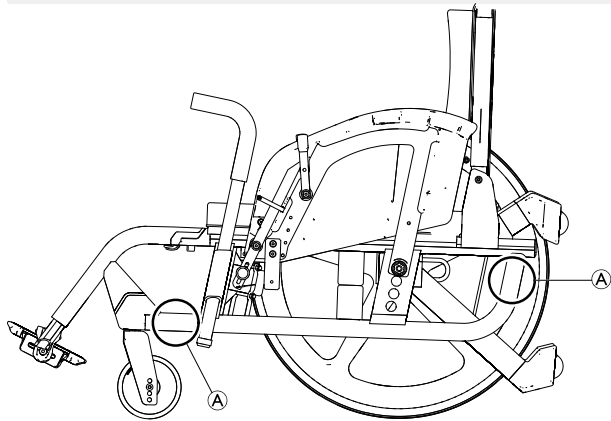

1. Fold down the backrest if necessary, see *5.9 Backrest, page 21*.
2. Always lift the wheelchair by gripping the frame at points **(A)**.

To carry the frame when the wheelchair is dismantled, also hold the frame at points **(A)**.

7.5 Transporting the occupied wheelchair in a vehicle

Even when the wheelchair is properly secured and the following rules are met, injuries to passengers may occur in a collision or sudden stop. Invacare therefore strongly recommends transferring the wheelchair user to the vehicle seat with the seat belt on. Do not make alterations or substitutions to points of the wheelchair (structure, frame or parts) without the written consent of Invacare. The wheelchair has been successfully tested according to the requirements of ISO 7176–19.

To transport the wheelchair with user in a vehicle, a restraint system must be installed in the vehicle. Wheelchair tie-downs and occupant restraint systems must be approved according to ISO 10542-1. Contact your Invacare distributor or your provider for more information on getting and installing an approved and compatible restraint system.



WARNING!

Risk of accidents

Risk of accidents due to the usage of an inadequate restraint system.

- Make sure that the restraint system is designed for the user's weight.

**WARNING!**

If, for some reason, it is impossible to transfer the wheelchair user to a vehicle seat, the wheelchair can be used as a seat in a vehicle if the following procedures and regulations are followed. A transportation kit (optional) has to be fitted on the wheelchair for such a purpose.

- The wheelchair must be secured in the vehicle with a 4-point wheelchair restraint system.
- The user must wear a 3-point passenger restraint system secured to the vehicle.

**WARNING!**

Safety restraint devices must only be used when the wheelchair user's weight is 22 kg or more (ISO-7176-19).

- Do not use the wheelchair as a seat in a vehicle when the user weight is lower than 22 kg.

**WARNING!**

- Before journey contact transporter and request information about the capability for the below required equipment.
- Make sure there is sufficient free space around the wheelchair and user to avoid the user making contact with other vehicle occupants, unpadded parts of the vehicle, wheelchair options or anchor points of the restraint system.

**WARNING!**

- Make sure the tie-down points at the wheelchair are not damaged and that the parking brakes are fully functional.

**WARNING!**

Injury or damage may occur from wheelchair components or options loosened during a collision or sudden stop.

- Ensure all removable or detachable components and options are removed from the wheelchair and securely stored in the vehicle.
- It is essential to have your wheelchair checked by your provider after an accident, collision etc.

**IMPORTANT!**

- Refer to the user manuals supplied with the restraint systems.
- The following illustrations may differ depending on the restraint system supplier.

Securing the wheelchair with a 4-point restraint system

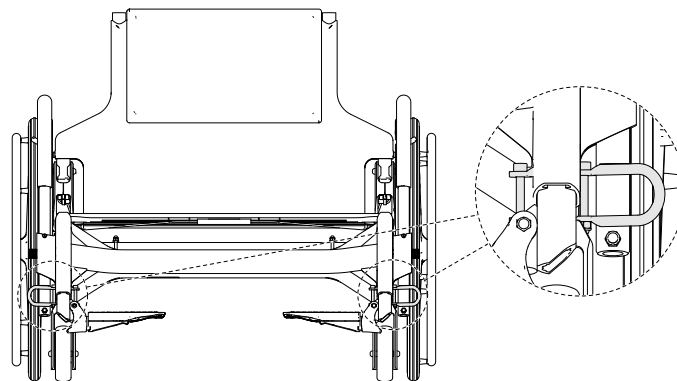
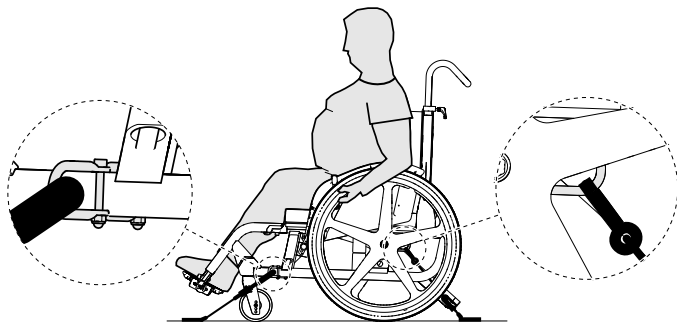

WARNING!

- Place the wheelchair with the user forward-facing in direction of vehicle travel.
- Engage the parking brakes.

The wheelchair tie-down positions where the restraint system straps must be placed are marked with snap hook symbols (see following figures and section 2.3 *Labels and symbols on the product, page 7*).

1. Using the front and rear straps of the 4-point restraint system, secure the wheelchair to the vehicle mounted rails. Refer to the user manual supplied with 4-point restraint system.

Front side tie-down positions for belt straps:

1. Attach the front straps to the eyelets **A** of the transportation kit on both sides (see location of the attachment labels).
2. Attach the front straps to the rail system referring to best practice recommended instructions from the safety belt manufacturer.
3. Disengage the parking brakes and apply tension to the front straps by pulling the wheelchair backwards from the rear.
4. Engage the parking brakes.

Rear side tie-down positions for snap hooks:

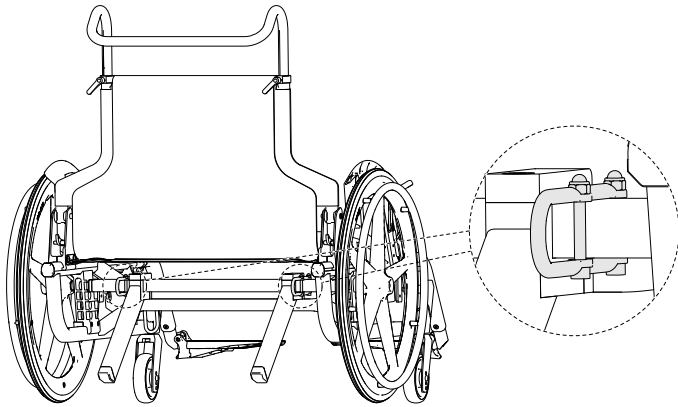

1. Attach the snap hooks to the eyelets of the transportation kit on both sides (see location of the attachment labels).
2. Attach rear straps to the rail system referring to best practice recommended instructions from the safety belt manufacturer.
3. Tighten the straps.



IMPORTANT!

- Check the plungers are fully engaged on both sides and located in the same position of the cut-out section of the rail.
- Make sure that the angle between the rails and the straps lies between 40° and 45°.

Fastening the 3-point passenger restraint system

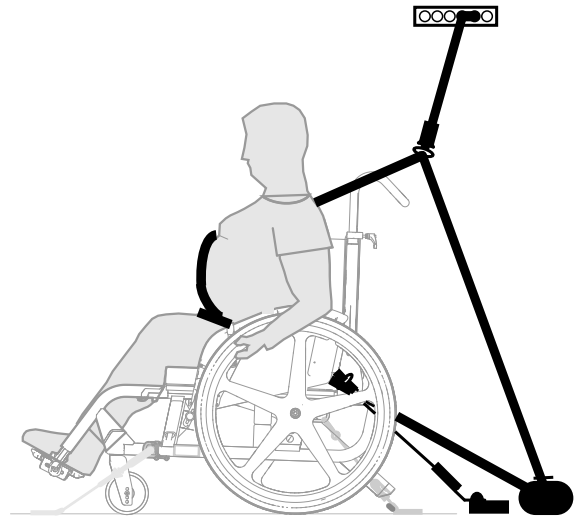

IMPORTANT!

The illustration above may differ depending on the restraint system supplier.

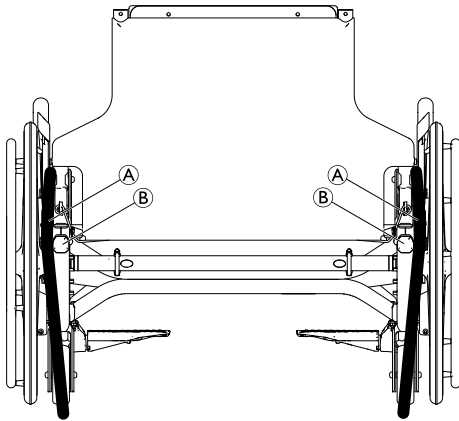

IMPORTANT!

- Make sure that the rear 3-point restraint belts **A** are led on the outside of the frame **B**.



WARNING!

- Ensure the 3-point passenger restraint system fits as tightly across the user's body as possible without discomfort and no part is twisted.
- Ensure the 3-point passenger restraint system is not held away from the user's body by parts of the wheelchair such as armrests or wheels etc.
- Ensure the user restraint has a clear path from the user to the anchor point without interference by any part of the vehicle, wheelchair, seating.
- Ensure the lap belt fits snugly over the occupant's pelvis and is not allowed to ride up into the abdominal area.
- Ensure the user is able to reach the release mechanism unaided.



1. Install the 3-point passenger restraint system referring to the user manual supplied with your 3-point restraint system.

**IMPORTANT!**

- Apply the lap belt of the 3-point passenger restraint system low across the pelvis so that the angle of the lap belt is within the preferred zone (A) of 30° to 75° to the horizontal. A steeper angle is preferred, but never exceeding 75°.

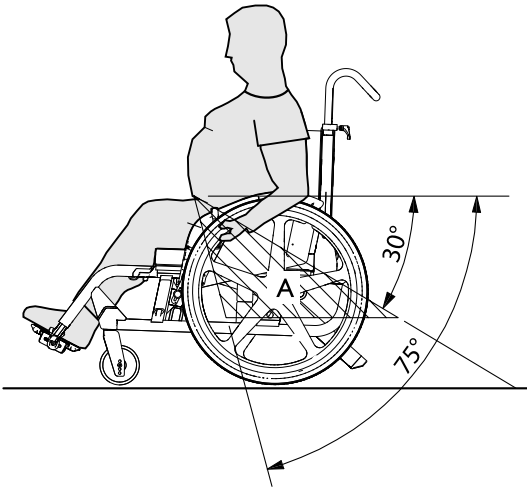

8 Maintenance

8.1 Safety information



WARNING!

Some materials deteriorate naturally over time. This could result in damage to wheelchair components.

- Your wheelchair should be checked by a qualified technician at least once a year or if it has not been used for a long period.



Packaging for return

The wheelchair shall be sent to the authorized provider in an appropriate packaging to avoid damage during the shipment.

8.2 Maintenance Schedule

To ensure safe and reliable operation, carry out the following checks and maintenance regularly or have it carried out by another person.

	weekly	monthly	annually
Check that rear wheels are seated correctly	x		
Check the adjustment of the backrest joint	x		
Check the posture belt	x		

	weekly	monthly	annually
Visual check		x	
Check the castors		x	
Check the ball castors (transportation bearing)		x	
Check bolts		x	
Check the parking brakes		x	
Have wheelchair checked by your provider			x

Check that rear wheels are seated correctly

1. Pull on the rear wheel to check that the removable axle is seated correctly. The wheel should not come off.
2. If the rear wheels are not engaged properly, remove any dirt or deposits. If the problem persists, have the removable axles reinstalled by your provider.



IMPORTANT!

Daily use of the wheelchair may wear out the rear wheel.

- Make sure that the rear wheels are at least changed every year.

Check the adjustment of the backrest joint

1. Sit in the wheelchair and lean back on the backrest. The backrest must be correctly engaged.
2. Pull the release cord. The pins must be free-moving on both sides. Otherwise, the backrest joint will have to be readjusted by your provider.

Check the posture belt

1. Check that the posture belt is adjusted correctly.



IMPORTANT!

- Loose posture belts must be adjusted by your provider.
- Damaged posture belts must be replaced by your provider.
- Posture belts must always be installed by your provider.

Visual check

1. Examine your wheelchair for loose parts, cracks or other defects.
2. If you find anything, have your wheelchair checked immediately by your provider.

Check the castors

1. Check that the castors turn freely.
2. Remove any dirt or hair from the castor bearings.
3. Faulty or worn out castors must be replaced by your provider.

Check the ball castors (transportation bearing)

1. Check that the ball castors turn freely.
2. Remove any dirt or hair from the ball castors.
3. Faulty or worn out ball castors must be replaced by your provider.

Check the bolts

Bolts can work loose through constant use.

1. Check that the bolts are tight (on the footrest, seat cover, sides, backrest, frame, seat module).
2. Tighten any loose bolts with the suitable torque like described in the service manual. Service manuals can be obtained from Invacare.



IMPORTANT!

- Self-locking screws/nuts or thread-locking adhesive are used for several connections. If these are loosened, they must be replaced by new self-locking screws/nuts or they must be secured using new thread-locking adhesive.
- Self-locking screws/nuts must be replaced by your provider.

Check the parking brakes

1. Check that the parking brakes are positioned correctly. The parking brake is set correctly if the brake shoe depresses the tyre by a few millimeters when the parking brake is engaged.
2. If you find that the setting is not correct, have the parking brakes correctly adjusted by your provider.

! **IMPORTANT!**

The parking brakes must be readjusted after replacing the rear wheels or changing their position.

Checking after a heavy collision or blow

! **IMPORTANT!**

The wheelchair can sustain visibly undetectable damage as a result of a heavy collision or hard blow.

- It is essential to have your wheelchair checked by your provider after a heavy collision or hard blow.

Spare parts

 All spare parts can be obtained from your wheelchair provider.

8.3 Cleaning and Disinfection

8.3.1 General Safety Information



CAUTION!
Risk of Contamination

– Take precautions for yourself and use appropriate protective equipment.

! **IMPORTANT!**

Wrong fluids or methods can harm or damage the product.

- All cleaning agents and disinfectants used must be effective, compatible with one another and must protect the materials they are used to clean.
- Never use corrosive fluids (alkalines, acid etc.) or abrasive cleaning agents. We recommend an ordinary household cleaning agent such as dishwashing liquid, if not specified otherwise in the cleaning instructions.
- Never use a solvent (cellulose thinner, acetone etc.) that changes the structure of the plastic or dissolves the attached labels.
- Always make sure that the product is completely dried before taking it into use again.



For cleaning and disinfection in clinical or long-term care environments, follow your in-house procedures.

8.3.2 Cleaning Intervals



IMPORTANT!

Regular cleaning and disinfection enhances smooth operation, increases the service life and prevents contamination.

Clean and disinfect the product

- regularly while it is in use,
- before and after any service procedure,
- when it has been in contact with any body fluids,
- before using it for a new user.

8.3.3 Cleaning



IMPORTANT!

- The product does not tolerate cleaning in automatic washing plants, with high-pressure cleaning equipment or steam.



IMPORTANT!

- Dirt, sand and seawater can damage the bearings and steel parts can rust if the surface is damaged.
- Only expose the wheelchair to sand and seawater for short periods and clean it after every trip to the beach.
 - If the wheelchair is dirty, wipe off the dirt as soon as possible with a damp cloth and dry it carefully.

1. Remove any installed optional equipment (only optional equipment which does not require tools).
2. Wipe down the individual parts using a cloth or soft brush, ordinary household cleaning agents (pH = 6 - 8) and warm water.
3. Rinse the parts with warm water.
4. Thoroughly dry the parts with a dry cloth.



Car polish and soft wax can be used on painted metal surfaces to remove abrasions and restore gloss.

Cleaning upholstery

For cleaning upholstery refer to the instructions on the labels of the seat, cushion and backrest cover.

8.3.4 Disinfection



Information on recommended disinfectants and methods can be found on <https://vah-online.de/en/for-users>.

1. Wipe down all generally accessible surfaces with a soft cloth and ordinary household disinfectant.
2. Allow the product to air-dry.

9 After Use

9.1 Storage



IMPORTANT!

- Risk of damage to the product
- Do not store the product near heat sources.
 - Never store other items on top of the wheelchair.
 - Store the wheelchair indoors in a dry environment.
 - Refer to temperature limitation in chapter 11.3 *Environmental conditions, page 49.*



To safe place, the wheelchair can be stored on the transportation bearing, see 7.2 *Transportation Bearing, page 32.*

After long-term storage (more than four months) the wheelchair must be inspected in accordance to chapter 8 *Maintenance, page 40.*

9.2 Reconditioning

This product is suitable for reuse. To recondition the product for a new user, carry out the following actions:

- Inspection
- Cleaning and disinfection
- Adaptation to the new user

For detailed information, see 8 *Maintenance, page 40* and the service manual for this product.

Make sure that the user manual is handed over with the product.

If any damage or malfunction is detected, do not reuse the product.

9.3 Disposal

Be environmentally responsible and recycle this product through your recycling facility at its end of life.

Disassemble the product and its components, so the different materials can be separated and recycled individually.

The disposal and recycling of used products and packaging must comply with the laws and regulations for waste handling in each country. Contact your local waste management company for information.

10 Troubleshooting

10.1 Safety information

Faults may arise as a result of daily use, adjustments or changing demands on the wheelchair. The table below shows how to identify and repair faults.

**CAUTION!**

– Contact a qualified technician immediately if you notice a fault with your wheelchair, for example, a significant change in handling.

**IMPORTANT!**

– Some of the actions listed must be carried out by a qualified technician. These are indicated. We recommend that *all* adjustments are carried out by a qualified technician.

10.2 Identifying and repairing faults

Fault	Possible cause	Action
The wheelchair does not travel in a straight line	Castors are not aligned correctly	Correct position and alignment of the castors, → qualified technician
	Castor wheel bearings are dirty or damaged	Clean or replace the bearings, → qualified technician
	Rear wheels are off track	Change track, → qualified technician
	Castor wheels not adjusted to same height	Position the castor wheels such that they touch the floor at the same time, → qualified technician
Removable axles cannot be inserted correctly	Removable axles dirty	Clean removable axles
	Removable axles misaligned	Adjust removable axles, → qualified technician
The parking brakes are gripping poorly or asymmetrically	Parking brake setting incorrect	Correct the parking brake setting, → qualified technician
Rolling resistance is very high	Rear wheels not parallel	Ensure the rear wheels are parallel, → qualified technician
Castors wobble when moving fast	Too little tension in castor bearing block	Tighten the nut on the bearing block axle slightly, → qualified technician
	Castor wheels have worn smooth	Change castor wheels, → qualified technician
The castor wheel is stiff or stuck	Bearings are dirty or faulty	Clean or replace the bearings, → qualified technician

11 Technical Data

11.1 Dimensions and weight

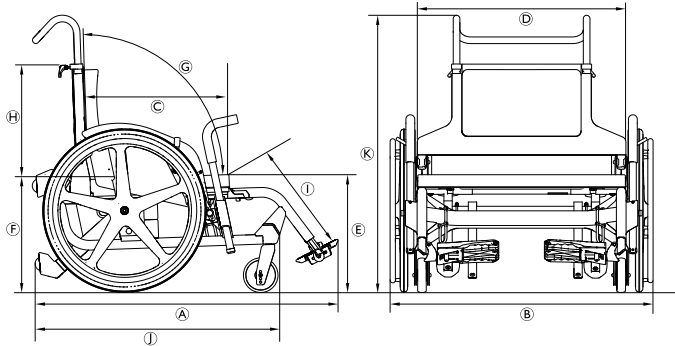

		Seat width 505 mm	Seat width 750 mm
	Maximum user weight	300 kg	
Ⓐ	Overall length with leg rests	1065 mm	1145 mm
Ⓑ	Overall width	705 mm	960 mm
	Total mass	27,5 kg	29,5 kg
	Mass of the heaviest part	20 kg	22 kg
	Static stability downhill	26,5°	
	Static stability uphill	36°	
	Static stability sideways	24°	
	Seat plane angle	5°	6°
Ⓒ	Effective seat depth	450 mm	495 mm
Ⓓ	Effective seat width	518 mm	765 mm
Ⓔ	Seat surface height at front edge	350 mm	410 mm

		Seat width 505 mm	Seat width 750 mm
Ⓕ	Seat surface height at rear edge	340 mm	400 mm
Ⓖ	Backrest angle	92°	94°
Ⓗ	Backrest height	485 mm	520 mm
Ⓘ	Footrest-to-seat distance	380 – 408 mm	333 – 420 mm
	Leg-to-seat-surface angle	136°	
	Hand rim diameter	520 mm	
	Horizontal location of axle	87 mm	90 mm
	Minimum turning radius	855 mm	970 mm
	Stowage width	648 mm	875 mm
	Stowage height	481 mm	415 mm
	Stowage length	875 mm	975 mm
Ⓙ	Overall length without leg rests	855 mm	920 mm
Ⓚ	Overall height	805 – 955 mm	

		Seat width 505 mm	Seat width 750 mm
	Pivot width	1420 mm	1660 mm
	Maximum slope angle brake	7°	

All dimension and weight specifications refer to a wide range of the wheelchair in a standard configuration. Dimension and weight (based on ISO 7176–1/5/7) may alter according to different configurations. In some configurations, the wheelchair exceeds the recommended dimensions for a wheelchair.



IMPORTANT!

- In some configurations, the overall dimensions of the wheelchair when it is ready for use exceeds the authorised limits and the access to emergency escape routes is not possible.
- In some configurations, the wheelchair exceeds the size recommended for travelling by train in the EU.

11.2 Materials

The components used to manufacture the wheelchair consist of the following materials:

Frame tubes	Aluminum
Backrest tubes	Aluminum
Axle tube	Aluminum

Seat cover / Backrest cover	PA / PE / PVC
Push handles	Steel / Aluminum / TPE
Clothes-guard	Plastic
Castor forks	Aluminum
Leg rests	Aluminum
Footplate	Plastic
Parking brakes	Steel / Plastic
Solid tyres	Rubber
Handrim	Aluminum
Supporting parts / Attachments	Steel / Aluminum
Screws and bolts	Steel

All components have either a protective coating or are corrosion resistant.

11.3 Environmental conditions

	Storage and transportation	Operation
Temperature	-20 °C to 40 °C	-5 °C to 40 °C
Relative humidity	20 % to 90 % at 30 °C, not condensing	
Atmospheric pressure	800 hPa to 1060 hPa	

Invacare distributors

Asia:

Invacare Asia Ltd.
1 Lenton Place, North Rocks NSW 2151
Australia
Phone: (61) (02) 8839 5333
Fax: (61) (02) 8839 5343
asiasales@invacare.com
www.invacare.com

Ireland:

Invacare Ireland Ltd,
Unit 5 Seatown Business Campus
Seatown Road, Swords, County Dublin
Tel : (353) 1 810 7084
Fax: (353) 1 810 7085
ireland@invacare.com
www.invacare.ie

United Kingdom:

Invacare Limited
Pencoed Technology Park, Pencoed
Bridgend CF35 5AQ
Tel: (44) (0) 1656 776 222
Fax: (44) (0) 1656 776 220
uk@invacare.com
www.invacare.co.uk

Australia:

Invacare Australia Pty. Ltd.
1 Lenton Place, North Rocks NSW 2151
Australia
Phone: 1800 460 460
Fax: 1800 814 367
orders@invacare.com.au
www.invacare.com.au

New Zealand:

Invacare New Zealand Ltd
4 Westfield Place, Mt Wellington 1060
New Zealand
Phone: 0800 468 222
Fax: 0800 807 788
sales@invacare.co.nz
www.invacare.co.nz



Invacare France Operations SAS
Route de St Roch
F-37230 Fondettes
France

1650186-A 2019-12-05



Making Life's Experiences Possible®



Yes, you can.®