



FOLDING  
CARBON

**HELIO kids**

ENHANCED AUTONOMY FOR BIG SMILES



## ENHANCED AUTONOMY FOR BIG SMILES

The HELIO Kids wheelchair by Motion Composites was designed to keep up with the active lives of children. Playing with friends, going to school, having fun and getting around easily... kids should be free to be kids! That's why we chose a carbon fiber design that is incredibly light and improves everyday mobility while being exceptionally strong. Boasting a colorful and fun look, HELIO Kids will accompany your child as they grow through their busy days and full life.

World-renowned, Motion Composites uses its know-how and its passion for innovation to design unique, cutting-edge products inspired by you. As a visionary and passionate company, our ambition is driven by your experience.

We believe that high-performance wheelchairs enhance people's lives with components, design, features and quality. HELIO Kids is our passion for performance, our commitment to quality and our vision of greater freedom brought to life.

GO BEYOND!





*This is Emerson's second Helio Kids. She loves her pink chair and how light it is for her and easy to maneuver. It has many customization options and it's built to accommodate growth. We also love the fact that it is foldable and that the wheels are removable.*

– The Bourque Family, Ontario, Canada

## ULTRALIGHT AND AGILE

- Lightweight for greater freedom of movement
- Engineered for kids

HELIO KIDS is one of the lightest pediatric folding wheelchairs on the market. We use high-performance carbon fiber for peak lightness and strength to ensure maximum agility. From the swing-away footrests to the forged aluminum axle plates, each component and accessory was chosen with weight reduction in mind.

## ADJUSTABLE AND PRECISE

- A chair that grows with your child
- Quick and precise adjustments

Kids grow fast and HELIO Kids is designed to grow right along with them. It only takes a few minutes to increase the seat depth by up to 3 inches (7.6 cm) in almost infinite increments for greater precision. The footplate height can be adjusted just as quickly and easily so your child is always comfortable.

## MANEUVERABILITY AND EASE OF PROPULSION

- Your energy is taking you further
- Mobile, agile, working for you

Ease of propulsion is an undeniable plus and, with the HELIO Kids, you'll enjoy remarkable agility. The molded cross brace maximizes the frame's stability, saving your child considerable energy on a daily basis to make every push count.

## STURDY AND DURABLE

- Strong enough to keep up with your child
- Unprecedented strength and stability

T700 carbon fiber is an ideal material for making high-performance wheelchairs, due to its incredible sturdiness and stability. Unlike standard two-part frames, HELIO KIDS has a rigid unibody (single) frame, which makes it much stronger. Kids can be tough on their wheelchairs, but this chair was made to last, serving your child for many years to come.

## FEATURES

### RIGID UNIBODY FRAME

Eliminates joints, reduces movement and maximizes efficiency

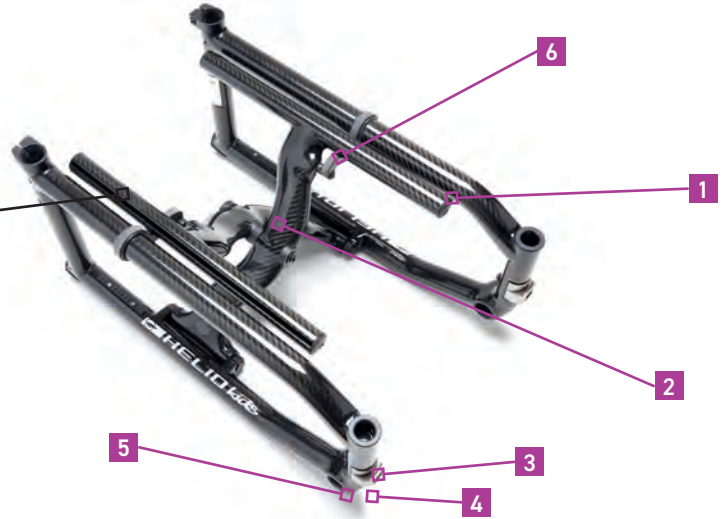

#### 1 CARBON SEAT RAIL

Fully molded with integrated seat slider for better seat sling support



#### 2 ULTRARIGID FOLDING SYSTEM

Offers best-in-class propulsion efficiency



#### 3 FOOTREST ANCHOR

Bracket is inset with an integrated friction plate to protect the carbon fiber



#### 4 INTEGRATED CASTER HOUSING

Offers simple and infinite angle adjustments.



#### 5 ANTI-FLUTTER SYSTEM

Provides a smooth, more efficient ride



#### 6 INJECTED PLASTIC CROSS BRACE LINKS

Lighter and more durable for more fluid movements

## TECHNOLOGIES



T-700

### T 700 HIGH-MODULUS CARBON FIBER

The lightest and most rigid material available, also renowned for its vibration damping properties.



RUF

### RIGID UNIBODY FRAME

A unibody frame is much stronger and requires less maintenance than a standard two-part frame. It also reduces weight while maximizing propulsion efficiency.



SMC 3D

### SYMMETRICAL MOLDED CROSS BRACE 3D

Entirely symmetrical carbon fiber cross brace for reduced torsion and better energy distribution throughout the frame.



UFS

### ULTRARIGID FOLDING SYSTEM

High-precision tolerances and oversized pivot axles for best-in-class propulsion efficiency.



FVA\*

### FORGED VERTICAL AXLE PLATE

Offers the industry's most precise rear wheel adjustability. The vertical mounting maximizes stability and responsiveness.



ECH

### EVOLVE CASTER HOUSING

Integrated into the frame for rock-solid durability, the Evolve caster housing offers easy and precise infinite adjustments.



AFS

### ANTI-FLUTTER SYSTEM

Minimize flutter with a simple twist of a screw.



NEWTON

### NEWTON ACCESSORIES

Parts and accessories designed to be lighter with improved functionality.

## TECHNICAL SPECIFICATIONS

FRAME	Folding
MATERIAL	T700 High-modulus carbon fiber
TRANSPORT WEIGHT	10.6 lb.   4.8 kg (12 x 12 without rear wheels, wheel locks, armrests, cushion, anti-tippers and footrest)
LIGHTEST CONFIGURATION	20.7 lb.   9.4 kg without wheel locks and wheels
WEIGHT LIMIT	175 lb.   79 kg
WIDTH	12 in. to 16 in.   30.5 cm to 40.6 cm
DEPTH	12 in. to 19 in.   30.5 cm to 48.3 cm
FRONT SEAT-TO-FLOOR HEIGHT	13 in. to 21 ½ in.   33 cm to 54 cm (with 3 in. to 8 in. caster)
REAR SEAT-TO-FLOOR HEIGHT	12 ½ in. to 19 ½ in.   31.8 cm to 48.3 cm (with 20 in. to 24 in. wheel)

## DIMENSIONS



### SEAT WIDTH

12 in. to 16 in. | 30.5 cm to 40.6 cm



### SEAT DEPTH

12 in. to 19 in. | 30.5 cm to 48.3 cm



### FRONT SEAT-TO-FLOOR HEIGHT

13 in. to 21 ½ in. | 33 cm to 54.6 cm



### REAR SEAT-TO-FLOOR HEIGHT

12 ½ in. to 19 ½ in. | 31.8 cm to 48.3 cm



### BACK HEIGHT

9 in. to 21 in. | 22.9 cm to 53.3 cm



### ARMREST HEIGHT

8 in. to 14 in. | 20.3 cm to 35.6 cm



### FOOTREST ANGLE

60°, 70°, 80°, 90°



### BACK ANGLE

90° to 105°



### WHEEL CAMBER

0°, 3°, 6°



### CENTER OF GRAVITY

1 in. to 4 in. | 2.5 cm to 10.2 cm



### OVERALL WIDTH

18 ¾ in. min. to 26 7/8 in. max.  
47.6 cm min. to 68.3 cm max.



### WEIGHT LIMIT

175 lb. | 79 kg

## COLOR CHART

FRAME COLOR.  
CROSS BRACE IS  
HIGH-GLOSS CARBON  
FIBER FINISH.

Carbon Finish

Charcoal

Steel Blue

Sapphire Blue

Monster Green

Acid Green

Burgundy

Fuschia

Ferrari Red

Sunkissed Orange

## GO BEYOND!

Who we are: passionate innovators pushing the boundaries of what is possible. What we do: combine leading-edge engineering with innovative materials to create movement. What makes us proud: having our ultralight wheelchairs echo the love of life their users demonstrate each day. Through our unique approach and distinct attitude, our aim is to enhance lives, nourish a sense of freedom and revolutionize the way people see wheelchairs.

**LEARN MORE** To learn more about the HELIO KIDS and find more information regarding our products, visit our website at [motioncomposites.com](http://motioncomposites.com)



**T** 1 (866) 650-6555

**F** 1 (888) 966-6555

[motioncomposites.com](http://motioncomposites.com)