

CE

X850 Corpus 3G

User manual | British English

Welcome to the Permobil family

We hope that you enjoy your new powered wheelchair. Permobil's founder, Dr. Per Uddén, believed that every person has the right to have his or her disability compensated as far as possible using the same technology that we all use in our everyday life. Your new wheelchair is a state-of-the-art medical device designed to achieve this goal by providing unparalleled convenience, comfort, and technology.

Produced and published by Permobil
Edition: 5
Date: 2023-04-28
Order no: 334065 eng-UK

How to contact Permobil

Permobil Ltd.
Unit 7, Polaris Centre, 41 Brownfields
Welwyn Garden City, Herts, AL7 1AN
United Kingdom



+44 1484 722 888



+44 1484 723 013



info@permobil.co.uk



www.permobil.com



Production units. See page 69.



Local offices. See page 70.

Head office of the Permobil Group

Permobil AB
Per Uddéns väg 20
SE 861 36 Timrå
Sweden



+46 60 59 59 00



info@permobil.com



www.permobil.com

1	Introduction	4
2	Overview	5
2.1	Wheelchair specification	6
2.2	Tool bag	7
2.3	Control panel	8
2.4	Footplate extension	9
2.5	Lights and reflectors	10
2.6	Wheels	11
2.7	Tie-down points	12
2.8	Serial number label	13
2.9	Accessories	14
2.10	Spare parts	15
2.11	User manual	16
3	Safety	17
3.1	Types of warning signs	17
3.2	Warning signs	17
3.3	Labels	20
4	Wheelchair usage	22
4.1	Driving the wheelchair	22
4.2	Control panel, seat control panel, and joystick menu	26
4.3	Seat functions	31
4.4	Charging the batteries	35
4.5	Freewheel mode	35
4.6	Vehicle transportation	36
4.7	Air transportation	39
4.8	Rail transportation	39
4.9	Main circuit breaker	40
4.10	Wheelchair storage	40

4.11	Manual adjustments	40
4.11.1	Headrest	41
4.11.2	Backrest tilt	43
4.11.3	Removing the backrest	44
4.11.4	Armrest	44
4.11.5	Lumbar support	49
4.11.6	Trunk support	50
4.11.7	Rotational panel holder	51
4.11.8	Parallel panel holder	53
4.11.9	Positioning belt	55
4.11.10	Footplate extension	55
5	Maintenance	57
5.1	Maintenance and inspection schedule	58
5.2	Cleaning	59
5.3	Inflating the drive wheel tyres	60
5.4	Positioning belt	60
6	Troubleshooting	61
6.1	Troubleshooting guide	62
6.2	Error codes	64
7	General information	67
7.1	Guarantee	67
7.2	Standards and regulations	67
7.3	Reporting incidents	67
7.4	Disposal and recycling	67
7.5	Technical specifications	68

1 Introduction

Before you use your wheelchair for the first time, you must read and understand the contents of this user manual. It instructs you on how to properly and safely use and care for your wheelchair. You must also read and understand the user manuals for your specific accessories before you use your wheelchair. This user manual and additional product information are available at www.permobil.com or via telephone.

Your power wheelchair is a complex medical device prescribed to you by your healthcare provider and configured to meet your needs. Permobil is not responsible for inappropriate prescription or selection of models or features, or for improper use of or modifications to the wheelchair. If the wheelchair has an unexpected impact on your health, contact your healthcare provider.

The illustrations in this user manual are generic and may not be exact depictions of your wheelchair.

2 Overview

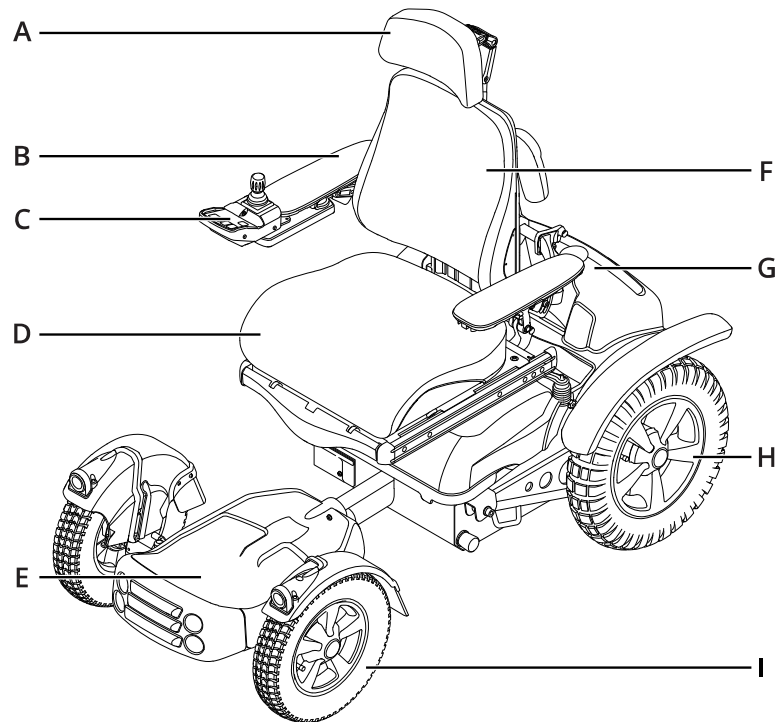

This chapter gives you an overview of your wheelchair. The parts in the overview illustration are described in more detail throughout the manual.

The X850 Corpus 3G is a rear-wheel drive power wheelchair for outdoor use. It is intended for people limited to a seated position.

The expected service life of this product is five years.

- | | |
|------------------|----------------|
| A. Headrest | F. Backrest |
| B. Armrest | G. Chassis |
| C. Control panel | H. Drive wheel |
| D. Seat | I. Front wheel |
| E. Footplate | |

2.1 Wheelchair specification

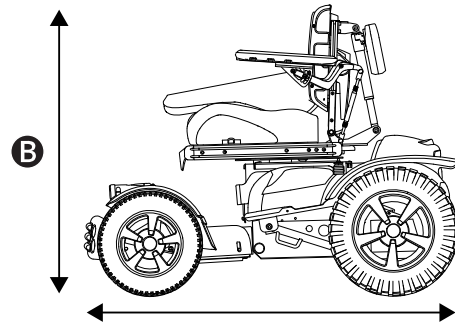
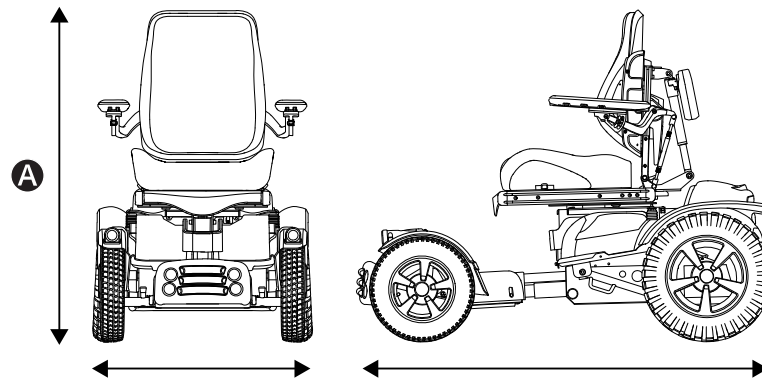

Product name: **X850 Corpus 3G**

Wheelchair class: **C**

A Height, width, and length

Height: 1020–1140 mm (40"–45")

Width: 715–790 mm (28"–31")

Length: 1260–1460 mm (50"–57.5")

B Smallest transportation size

Height: 930 mm (37")

Width: 715–790 mm (28"–31")

Length: 1260 mm (50")

Weight specification

Wheelchair with batteries: 203 kg (448 lb)

Maximum user weight: 136 kg (300 lb)

2.2 Tool bag

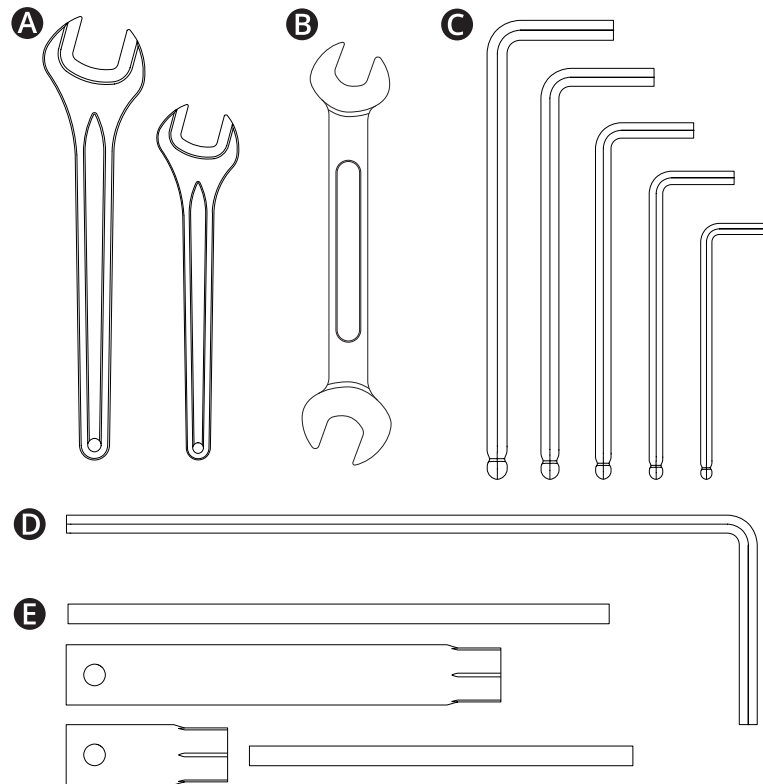

The wheelchair comes with a tool bag for maintenance and adjustments. It contains the following tools:

- Ⓐ Spanner
10 mm
14 mm
- Ⓑ Double-ended wrench
1/2"
9/16"
- Ⓒ Allen keys
2–6 mm
- Ⓓ Allen key
Long 6 mm
- Ⓔ Socket spanner
Long 13 mm
Short 15 mm

2.3 Control panel

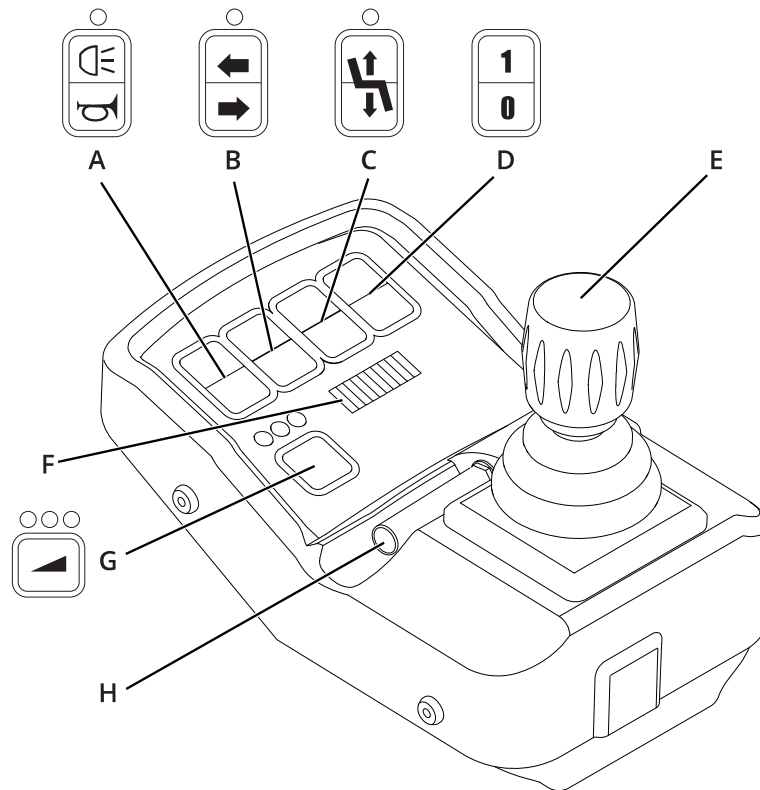

- A. Lights and horn
- B. Indicators
- C. Seat lift
- D. On/off
- E. Joystick
- F. Battery indicator
- G. Maximum speed
- H. Key

2.4 Footplate extension

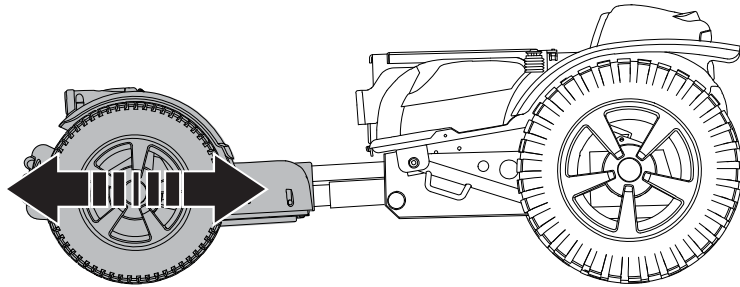

The seat control panel controls the power footplate extension.

 Power footplate extension. See page 34.

2.5 Lights and reflectors

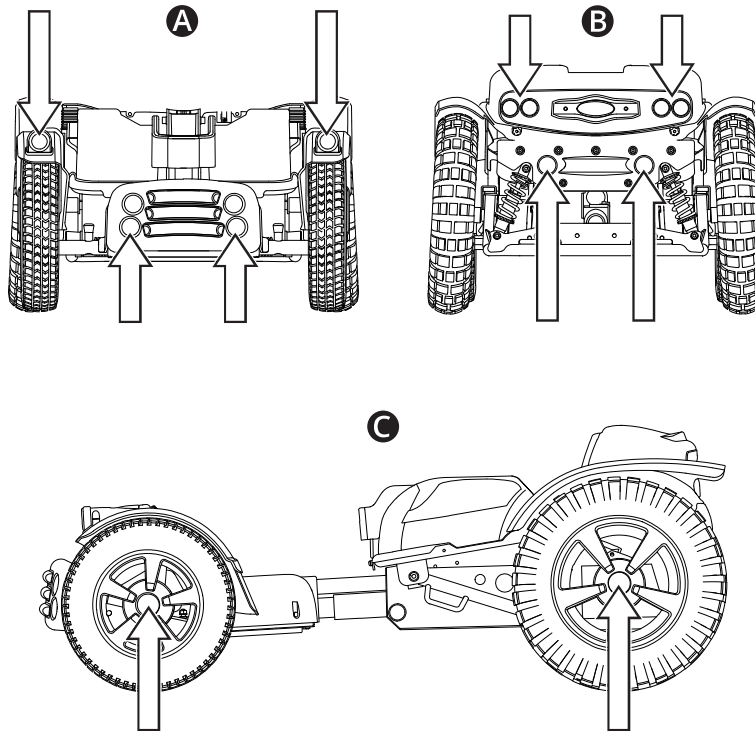

The wheelchair is equipped with reflectors at the front, the rear and the sides. It is also equipped with front lights, rear lights, and indicators.

- Ⓐ Front reflectors and front lights
- Ⓑ Rear reflectors and rear lights
- Ⓒ Side reflectors

2.6 Wheels

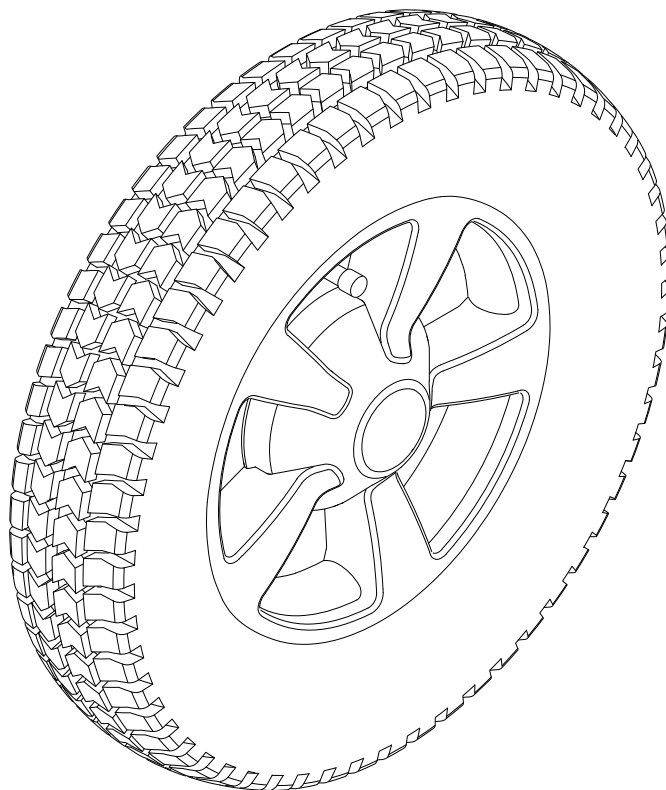



The wheelchair drive wheels have pneumatic tyres.

 Inflating the pneumatic tyres. See page 60.

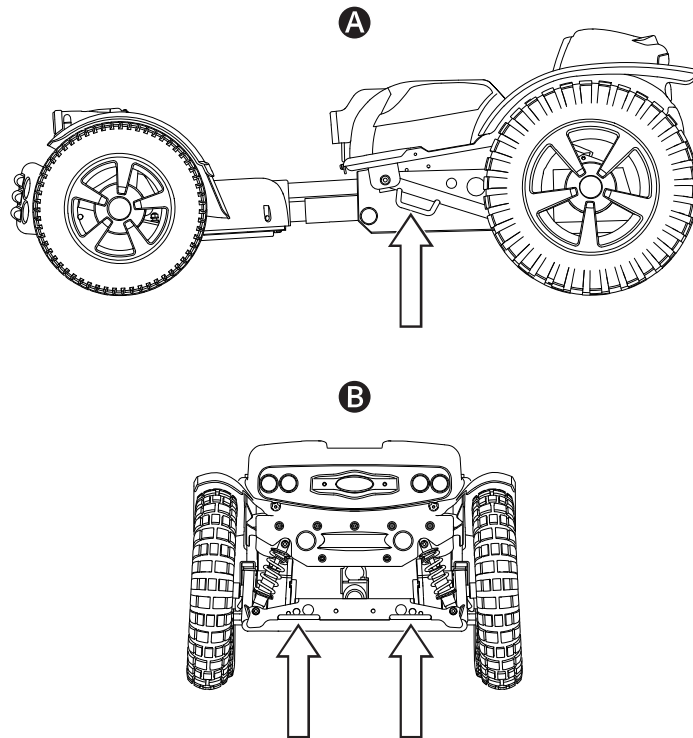
2.7 Tie-down points



The wheelchair is equipped with four tie-down points used for transportation . Two on the sides **A** and two at the rear **B**.

 Vehicle transportation. See page 36.

2.8 Serial number label

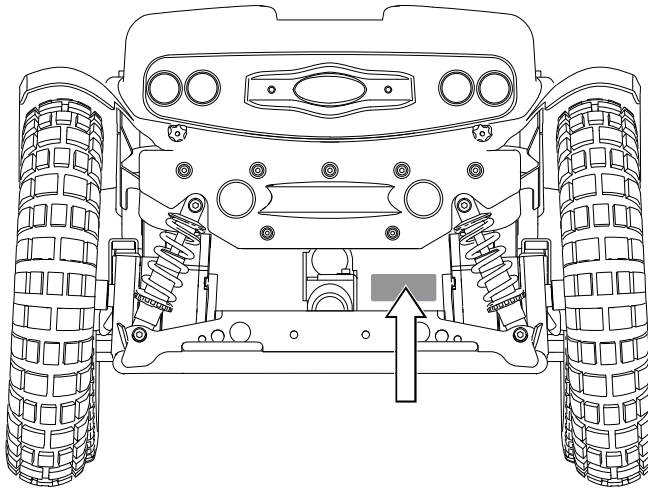

The serial number label is located on the rear of the wheelchair chassis.

The contents of the serial number label are described on page 20.

2.9 Accessories

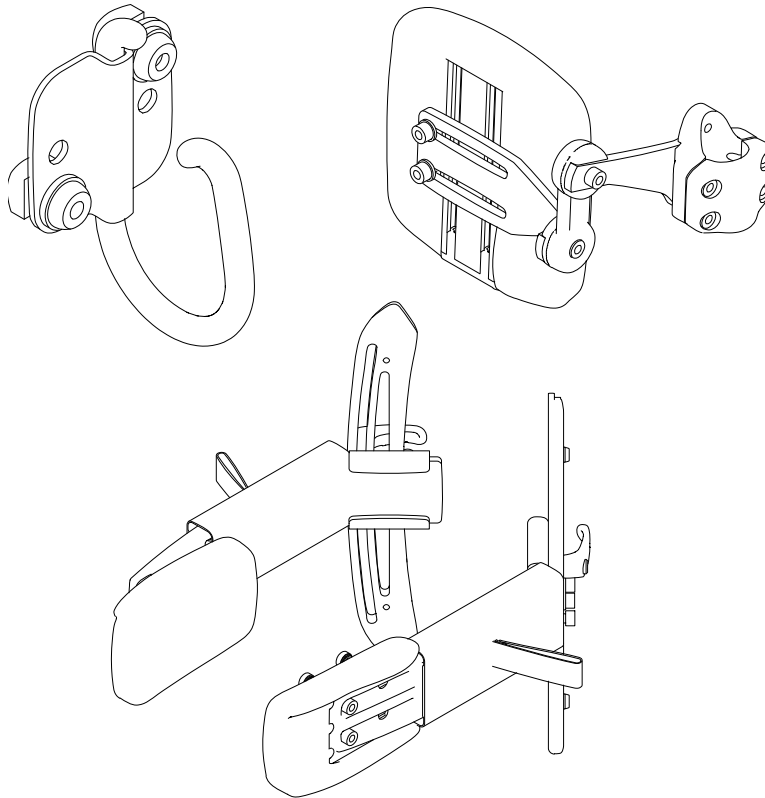

Accessories for Permobil products are subject to continuous development. Contact your nearest Permobil dealer for more information on the accessories available for your product. Only use accessories that are authorised by Permobil.

2.10 Spare parts

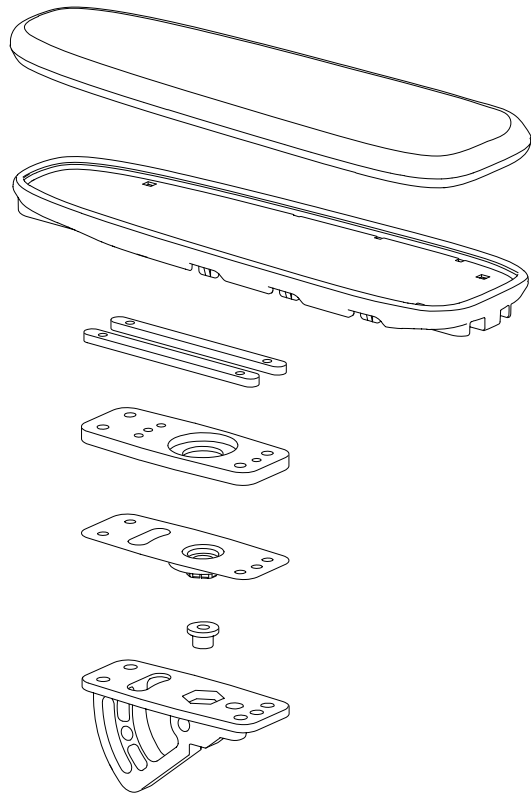

Spare parts must be ordered through Permobil.

Only use spare parts that are authorised by Permobil.

2.11 User manual

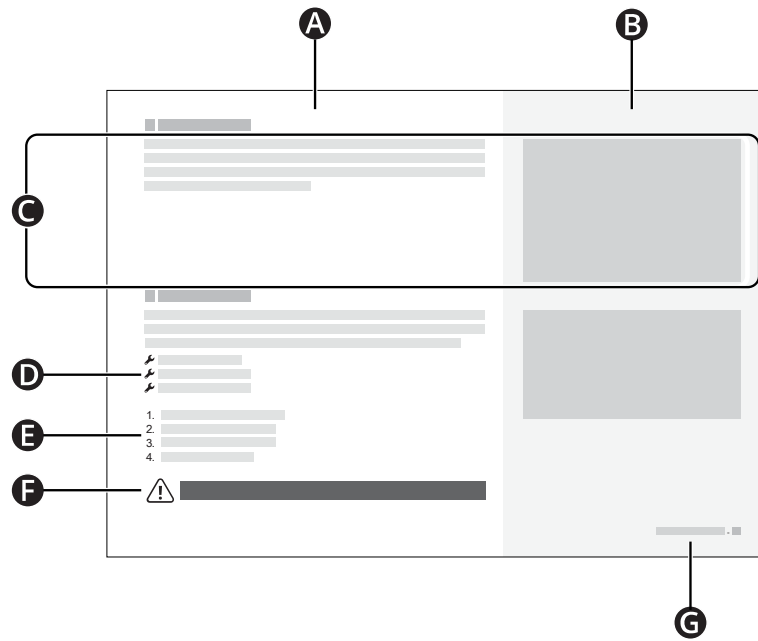

- A** Main text area
- B** Main illustration area
- C** Text correlates to the illustration to the right
- D** Tool list
- E** Instruction steps
- F** Warning sign
- G** Chapter and page number

3 Safety

Your wheelchair is a complex medical device and must be used safely. This chapter contains important information about how to safely use your wheelchair.

Permobil is not responsible for personal injuries or property damage resulting from any person's failure to follow the warnings and instructions in this user manual or from failure to exercise good judgement.

The following warnings are referenced throughout this user manual. Whenever you see the exclamation mark symbol, refer back to this chapter to review the appropriate warning.

3.1 Types of warning signs

The following types of warning signs are used in this manual:



WARNING!

Indicates a hazardous situation which, if not avoided, could result in serious injury or death as well as damage to the product or other property.



CAUTION!

Indicates a hazardous situation which, if not avoided, could result in damage to the product or other property.



IMPORTANT!

Indicates important information.

3.2 Warning signs



WARNING! Follow the warnings and instructions

Follow the warnings and instructions in this user manual. If you fail to do so, it could lead to bodily injury.



WARNING! Vehicle seating requirements

When you use the wheelchair as a seat in a vehicle, it must be forward-facing and you must use a three-point belt restraint, including a shoulder and pelvic belt, to reduce the risk of head and chest impacts with vehicle components. The wheelchair is only designed and tested for use in this configuration. If the wheelchair is used in another vehicle seating configuration, it can lead to bodily injury or death.



WARNING! Use tie-down points and docking systems properly

Make sure that you use tie-down points and docking systems properly. If you do not use them properly, it can lead to bodily injury or death.



WARNING! Pay attention to release mechanisms

Adjust your restraint system such that the release mechanisms cannot be pressed during a crash. If you fail to do so, it could lead to bodily injury or death.



WARNING! Positioning aids do not replace seatbelts

Wheelchair positioning aids do not replace vehicle mounted seatbelts. In a traffic accident, they do not provide the same protection as vehicle mounted seatbelts. If you use positioning aids as a seat belt, it can lead to bodily injury or death.



WARNING! Use positioning aids at all times

Use securely fastened positioning aids, including your positioning belt, at all times. If you do not, you can sustain bodily injuries.



WARNING! Do not overload the wheelchair

Do not use the wheelchair to pull any kind of object and never hang excessive weights on the wheelchair. If you do, the wheelchair may become less stable and injure you.



WARNING! Remain aware of your wheelchair's dimensions

Always remain aware of your wheelchair's dimensions. Some emergency exits or routes can be too small for your wheelchair to navigate through them.



IMPORTANT! Do not modify the wheelchair

Do not modify your wheelchair or any of its components. Your wheelchair has been configured specifically for your needs as prescribed by your healthcare provider. Special skills, training, and knowledge are needed to set up, modify, and repair the wheelchair.



WARNING! Avoid steep slopes

Do not drive the wheelchair on slopes steeper than 10°. If you do, the wheelchair may become less stable and injure you. For maximum performance and stability, use caution on slopes steeper than 10°.



WARNING! Use freewheel mode cautiously

Freewheel mode should only be used on level ground and when an attendant is present to control the wheelchair. If you use freewheel mode on an incline or without an attendant, you may get injured or cause property damage.



WARNING! Do not exceed the maximum user weight

Do not drive the wheelchair if you exceed the maximum user weight. If you do, the wheelchair can harm you or break.



WARNING! No passengers

Do not use the wheelchair to carry passengers, regardless of their age or weight. If you do, it could affect the wheelchair's manoeuvrability and stability.



WARNING! Drive extra carefully when lifted or tilted

If the seat or backrest is lifted or tilted on flat ground, drive at a low speed. If the seat or backrest is lifted or tilted, do not drive the wheelchair on slopes or over obstacles. If you do, the wheelchair may become less stable and injure you.



IMPORTANT! Do not use a damaged wheelchair

If the wheelchair or its accessories have suffered transportation damage, damage during driving, or damage from other causes, you must inform Permobil as soon as possible and immediately stop using your wheelchair. There is a risk that the wheelchair or its accessories can no longer be used safely. Contact your service provider or Permobil for further information.



WARNING! Keep the electronics dry

Make sure that the electronics are not exposed to moisture. If any of the shrouds or the joystick boot have cracks or tears, replace them immediately. Exposure to moisture can cause the wheelchair to short-circuit or catch fire, which may lead to personal injury or property damage.



WARNING! Do not get pinched

The wheelchair is heavy and contains many moving parts, which means that you can be pinched when you adjust the wheelchair or if you use the wheelchair incorrectly. When you see this warning, be mindful of your body location to avoid pinching accidents. Do not put any part of your body between moving parts.



IMPORTANT! Recycle all batteries

Used batteries must be disposed of responsibly in accordance with local recycling regulations.



WARNING! Use the recommended tyre pressure

Use the recommended tyre pressure. If you overfill the tyres, they may explode and cause bodily injury.



IMPORTANT! Electromagnetic fields

The electronics in a power wheelchair can be affected by external electromagnetic fields (for example mobile phones).



WARNING! Discontinue use after extraordinary events

Do not use your wheelchair if it has been dropped, crushed, exposed to fire, submerged in water, or involved in a vehicle accident, or other extraordinary events. Events like these may lead to significant damage that is impossible to detect upon inspection. Contact your service provider or Permobil. Damage caused by these types of incidents exceeds the limits covered by the manufacturer's guarantee.

3.3 Labels

Your wheelchair has labels that contain important information about safety and proper use. These labels are described in greater detail in this subchapter. Do not remove labels from the wheelchair. If a label becomes difficult to read or falls off, order a replacement from Permobil.

Serial number label

- A. Serial number of the wheelchair
- B. Maximum user weight
- C. Model: Model
- D. Link to patents
- E. Name and address of the manufacturer
- F. YYYY-MM-DD: Date of manufacture
- G. CE mark
 Medical device
- H. Unique Device Identification (UDI) as a GS1 DataMatrix including: date of manufacture and serial number

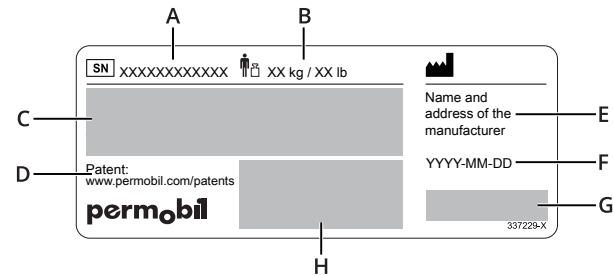

Risk of pinching

This label indicates a pinch risk. When you see this label, be extra careful to avoid pinching yourself or your belongings.



Main circuit breaker

This label shows the on and off positions for the main circuit breaker. Read more on page 40.

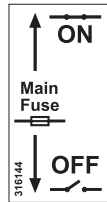

Freewheel mode

Read more about freewheel mode on page 35.



Tie-down points

This label shows the wheelchair's tie-down points. Read more about wheelchair transportation on page 36.



No passengers

This label means that no passengers are allowed.



4 Wheelchair usage

This chapter aims to provide you with basic information to quickly get started with your wheelchair, and also provide you with information you may need in your everyday use of the wheelchair. The following subchapters describe how to drive the wheelchair, how to use the most common seat functions, how to charge the batteries, how to enter and exit freewheel mode, and some helpful information if you want to transport your wheelchair. They also describe the main circuit breaker, wheelchair storage, and manual adjustments.

4.1 Driving the wheelchair

You must always drive your wheelchair carefully and defensively. Your wheelchair is a complex medical device, not a car. Due to the individualised nature of Permobil products, your wheelchair is equipped with one of numerous different ways to drive it. The most common way is described below, but your wheelchair may not conform to this process depending on its individualisation.

The key must be in place before you can start the wheelchair. Remove the key to lock the wheelchair.

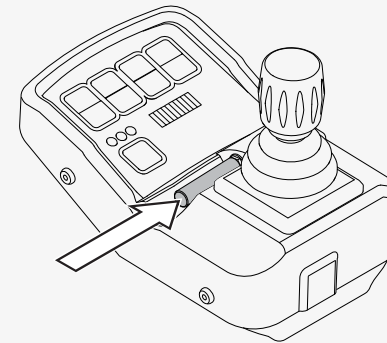

To drive your wheelchair, you must first turn on the power. The power button or switch is most commonly located on the wheelchair's control panel, which is usually attached to the armrest. Most Permobil wheelchairs also include a joystick on the control panel. Use this joystick to turn the wheelchair and to drive forwards and backwards. Simply press the joystick in the direction you want to go (A). The further you press the joystick, the faster the wheelchair will move. Release the joystick to stop moving.

Drive as gently as possible and avoid sudden braking. Do not turn off the power to stop the wheelchair. If you turn off the power while driving, the wheelchair will stop abruptly.

Do not move the joystick before, during, or immediately after you turn on the control system. If you move the joystick during this time, it can generate a joystick error. If this happens, turn the wheelchair off and then on.

For additional information on how to control your wheelchair, refer to any other documentation received with your wheelchair or contact your Permobil dealer.

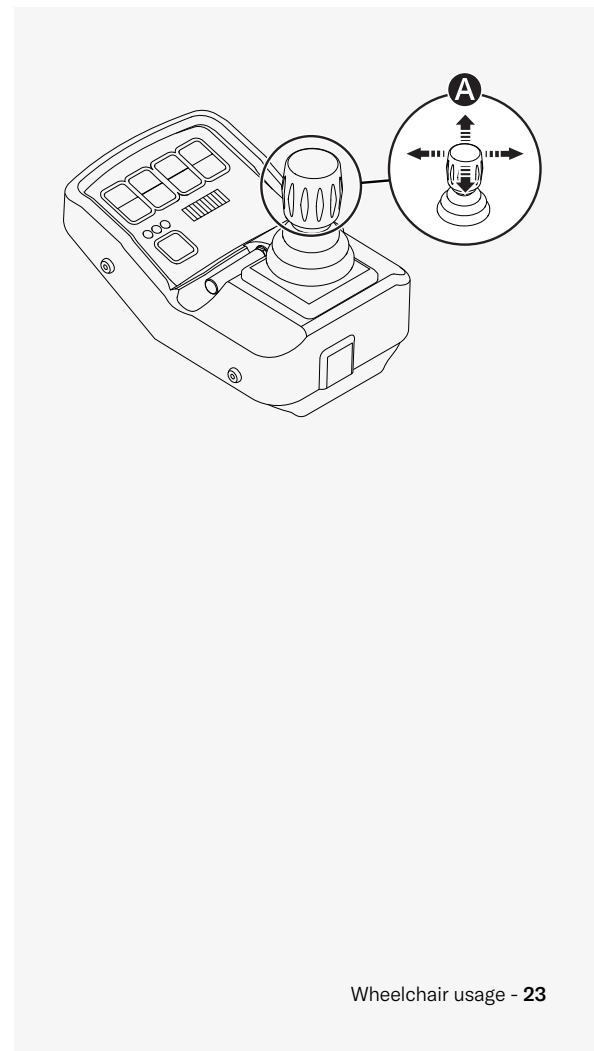

Turn off the power before you get in or out of the wheelchair or lift the armrest. Do not use the joystick as support when you get in or out of the wheelchair.

The first time you drive your wheelchair must be in the presence of a person who is qualified to ensure that the wheelchair is properly fit for you.

Make sure that your feet are correctly and securely positioned on the footplates before you drive the wheelchair.

4.1.1 Driving restrictions

The wheelchair consumes a lot of power when you drive up a hill, over obstacles, or on rough terrain (such as sand). Permobil recommends that you, as far as possible, avoid driving for a long period of time in these types of conditions.

Permobil recommends that you do not use the wheelchair in extreme conditions, such as heavy rain, thick snow, or excessive heat or cold. Prolonged exposure to sunlight or cold temperatures may cause wheelchair surfaces to become very hot or cold. The driving range of your wheelchair is approximately 40 km (25 miles) when the battery temperature is 25°C (77°F). The driving range is affected by the battery temperature. Temperatures below 25°C (77°F) can shorten the driving range. Temperatures below -25°C (-13°F) can harm the batteries.

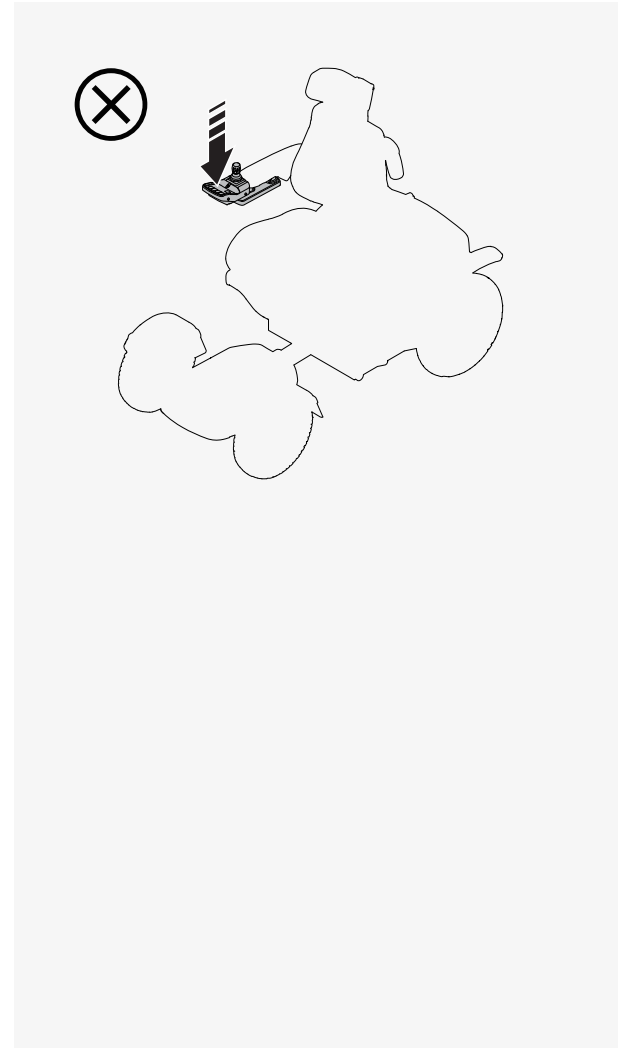

Do not use the wheelchair on stairs or escalators. Remember that alcohol can affect your ability to drive a power wheelchair.

This user manual's wheelchair specification states the wheelchair's maximum user weight. The stated user weight includes the user and any personal effects.

If the wheelchair is not behaving as it should, or if you suspect that something is wrong, stop the wheelchair as soon as possible, turn off the power and contact your service provider or Permobil for further information.

Avoid sudden stops and starts. Use caution in any of the following situations:

- when you are near edges or on elevated surfaces
- when driving on soft or uneven surfaces, such as grass, gravel, sand, ice, or snow
- when you drive from an area of high traction (such as a pavement) to an area of low traction (such as grass)
- when in narrow or confined spaces
- when there are ridges that could cause the wheelchair to move in a different direction

When you drive over an obstacle, always directly face it. You can drive over obstacles up to 100 mm (4"). If you drive over higher obstacles, there is a greater risk of tipping and of damage to the wheelchair. If a car lock is installed on the wheelchair, it affects the ground clearance.



When you drive downhill, additional precautions must be taken. Select the lowest maximum speed and proceed with caution. Driving down a slope can shift your centre of gravity forward. Release the joystick if the wheelchair is rolling faster than you would like. This makes the wheelchair stop, and you can descend again more slowly. Avoid sudden stops and starts. Note that the distance required to stop will increase when you drive downhill.

When driving uphill, drive straight up the slope, if possible.

4.2 Control panel, seat control panel, and joystick menu

This subchapter contains information about the control panel, the seat control panel, and the joystick menu. The control panel consists of a joystick, buttons and indicator lights. Your wheelchair can also have a seat control panel connected to the control panel. If it does, you can use either this or the control panel when you want to use the seat functions. You can use the joystick menu for both the control panel and the seat control panel.

4.2.1 Control panel

This subchapter gives you a short introduction to the buttons and indicator lights on the control panel.

4.2.1.1 Lights and indicator light

The lights button turns on the lights. Press it to turn the lights on and again to turn them off. When the lights are turned on, the indicator light is turned on.

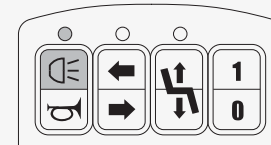

4.2.1.2 Horn

The horn button activates the horn. Press it to sound the horn.

4.2.1.3 Indicators and indicator light

The two indicator buttons activate the wheelchair's indicators. Press the right arrow to turn on the right indicator and the left arrow to turn on the left indicator. The indicator light on the panel will flash when an indicator is turned on.

4.2.1.4 Seat lift and indicator light

The seat lift button activates the seat lift. The indicator light is turned on when the seat lift is activated. Read more in [Seat functions](#).

4.2.1.5 On/off

The on/off button turns the wheelchair on and off. Press the top of the button to turn the wheelchair on and the bottom of the button to turn it off. If you press the bottom of the button, you can also stop any wheelchair functions.

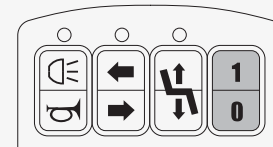
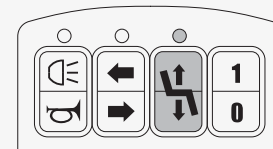
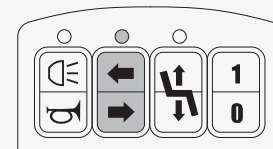
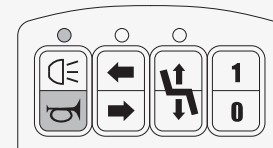

4.2.1.6 Maximum speed and indicator lights

The maximum speed button sets the maximum speed of the wheelchair. Press the button to cycle through the three different settings. The indicator lights show the current setting.

- The low setting is shown with one indicator light and allows a maximum speed of 3 km/h (1.9 mph).
- The medium setting is shown with two indicators lights and allows a maximum speed of 9 km/h (5.6 mph).
- The high setting is shown with three indicator lights and allows a maximum speed of 15 km/h (9.3 mph).

4.2.1.7 Battery indicator

The battery indicator shows how much battery power is left. It will show an updated value after about a minute of driving. The value shown is an estimate. The battery indicator flows up and down when the battery is being charged.

- Red, yellow, and green LEDs mean that the battery is fully charged.
- Red and yellow LEDs mean that the battery is partly charged.
- Red LEDs mean that you should charge the battery.



4.2.2 Seat control panel

The seat control panel sits behind the control panel. You can control seat functions with the seat control panel. Read more in 4.3 *Seat functions*. You can activate the seat control panel from the joystick menu.

4.2.3 Joystick menu

This chapter tells you how to enable and disable the joystick menu, how to enter and exit the joystick menu and how to use different functions.

You can enable and disable the joystick menu. To enable it, press and hold the lights button and the right turn indicator button when you turn on the wheelchair. Three beeps indicate that the joystick menu is enabled. Turn off the wheelchair and repeat the process to disable the joystick menu. Two beeps indicate that the joystick menu is disabled.

When the joystick menu is enabled, you can control the functions of the control panel or the seat control panel with the joystick. To do this, you first have to enter the joystick menu. Your wheelchair electronics must be configured before you can use the joystick to enter the joystick menu. Contact your service technician for assistance.

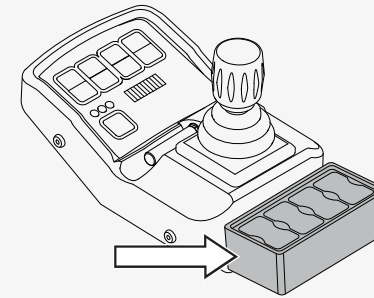

There are two ways to enter the joystick menu. One way is to hold down the lights button for two seconds. The other way is to move the joystick to the left or right end position and hold it there for two seconds. In both cases, a beep confirms that you have entered the joystick menu, and the indicator light above the lights and horn button is lit.

When the indicator light above a button is lit, move the joystick forwards to activate the function at the top of the button and move the joystick backwards to activate the function at the bottom of the button. Each step is followed by a beep. Move the joystick to the right or left to cycle through the different functions.

To change the maximum speed setting, move the joystick until the indicator above the maximum speed button is lit. Move the joystick forwards to increase the maximum speed. Move the joystick backwards to decrease the maximum speed.

If you want to activate the functions on the seat control panel, cycle through the functions until you reach the battery indicator. The first four LEDs (three red and one yellow) correspond to the functions on the seat control panel. The first LED is the first button from the left on the seat control panel. The second LED is the second button from the left and so on. Move the joystick forwards or backwards to activate a function, as usual.

There are three ways of exiting the joystick menu. You can move the joystick to the right until all ten LEDs and all indicator lights are lit. Move the joystick forwards. This activates drive mode again. You can also turn off the wheelchair. Pull the joystick backwards and hold it there for three seconds. Thirdly, you can activate an indicator. This automatically exits the joystick menu and activates drive mode.

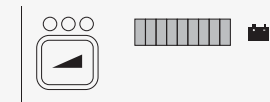
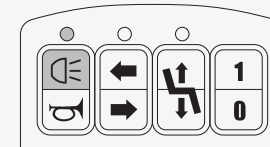

4.3 Seat functions

Your wheelchair may have seat functions. A seat function is a powered adjustment.

Permobil offers the following seat functions. Available functions may vary depending on the equipment fitted on your wheelchair.

- seat lift
- seat tilt
- seat rotation
- footplate extension
- backrest tilt

The wheelchair's centre of gravity changes when you change the position of the seat and/or the backrest. When you lift or tilt the seat or backrest, you decrease the wheelchair's stability.

4.3.1 Seat lift

The seat lift lifts and lowers the seat. When the seat is lifted, the maximum speed of the wheelchair is reduced automatically to 7 km/h (4.5 mph) forwards and 4 km/h (2.5 mph) backwards. You can use the control panel or the joystick menu to control this function.

To use the control panel, press the top of the button to raise the seat and the bottom of the button to lower the seat. See 4.2.1.4 *Seat lift and indicator light*

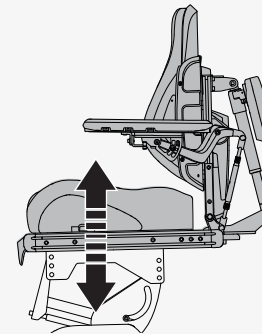

4.3.2 Seat tilt

The seat tilt tilts the entire seat. You can use either the seat control panel or the joystick menu to control the seat tilt. When the seat tilt is activated, the light above the seat lift button flashes to indicate that the seat lift cannot be used.

To use the seat control panel, press the bottom of the button to tilt backwards and the top of the button to tilt up again. See 4.2.2 *Seat control panel* for the location of the seat control panel.

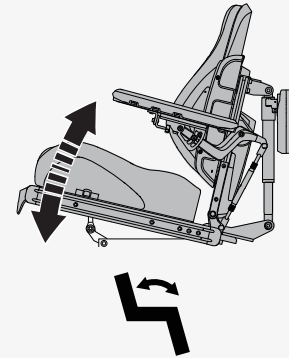

4.3.3 Seat rotation

The seat rotation function rotates the seat (B) to the right or to the left to make it easier to get into and out of the wheelchair. This function only works when the wheelchair is stationary. It is not possible to drive the wheelchair when the seat is rotated. Only use seat rotation on flat ground.

To make seat rotation easier, use the joystick to turn the front wheels as far as they will go to either the left or the right (A). Hold the joystick in the desired position and turn off the wheelchair on the control panel. Let go of the joystick and turn on the wheelchair again without touching the joystick. If you move the joystick, the front wheels will return to the neutral position, which is straight forwards.



WARNING! Do not get pinched

You can use either the seat control panel or the joystick menu to control seat rotation.

To use the seat control panel, press the top of the button to rotate the seat clockwise. Press the bottom of the button to rotate the seat anticlockwise. The seat rotates until it is at an end position or facing forwards. See 4.2.2 *Seat control panel* for the location of the seat control panel.

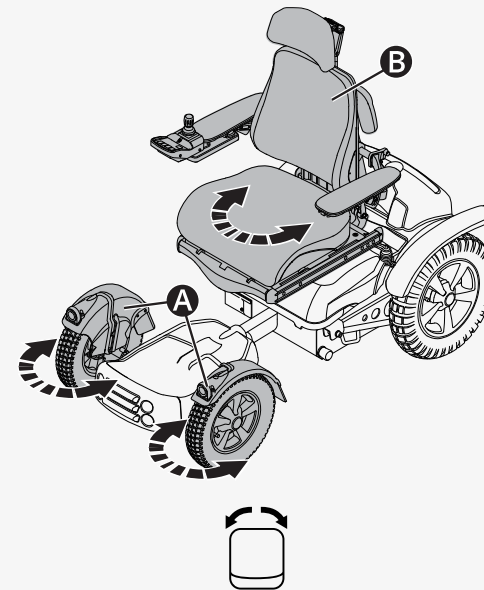

4.3.4 Power footplate extension

You can adjust the distance $\text{\textcircled{d}}$ between the footplate and the seat. The maximum distance is 200 mm (7¾ inches). When the extension is fully extended, the wheelchair drives more smoothly outdoors. When the extension is retracted, the wheelchair is easier to manoeuvre indoors.



WARNING! Do not get pinched

Use the seat control panel to adjust the footplate extension. Press the top of the button to increase the distance between the seat and the front wheels. Press the bottom of the button to decrease it. This function only works when the wheelchair is stationary. See 4.2.2 *Seat control panel* for the location of the seat control panel.

4.3.5 Backrest tilt

The backrest tilt tilts the backrest backwards and back up again. You can use either the seat control panel or the joystick menu to control backrest tilt.

To use the seat control panel, press the bottom of the button to tilt backwards and the top of the button to bring the backrest up again. See 4.2.2 *Seat control panel* for the location of the seat control panel.

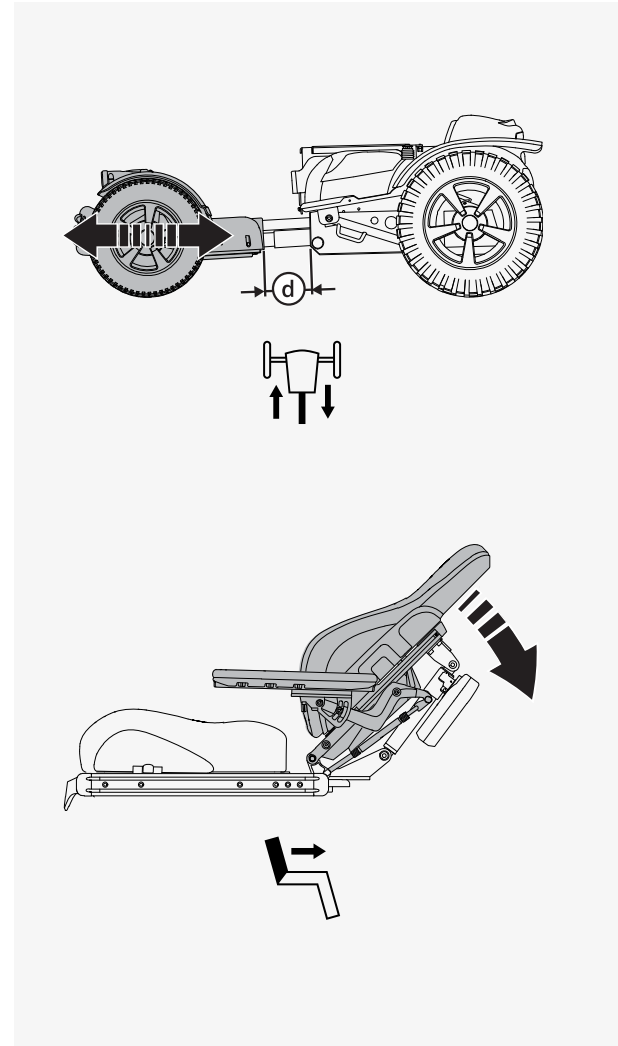

4.4 Charging the batteries

You can charge your wheelchair from the charging socket located on the right side of the chassis. Always connect the charger to the wheelchair first before you connect the charger to the wall.

Charge the wheelchair as often as possible. Do not use the wheelchair if the battery charge is low; otherwise you could become stranded. If the batteries become completely discharged, charge them immediately.

Charge the batteries in a well-ventilated, dry room. Never expose your batteries or any part of your wheelchair to an open flame. Only use a Permobil charger intended for use with your wheelchair. It is not possible to drive the wheelchair while it charges.

See the battery charger's manual for instructions and further information.

4.5 Freewheel mode

The wheelchair is fitted with a freewheel lever. When the freewheel lever is released, the wheelchair's brakes are disengaged from the motor. When in freewheel mode, the wheelchair can be moved manually, but cannot be controlled electronically.

When the wheelchair is in freewheel mode, it should not be possible to drive the wheelchair. If it can be driven, contact your service technician.



WARNING! Use freewheel mode cautiously

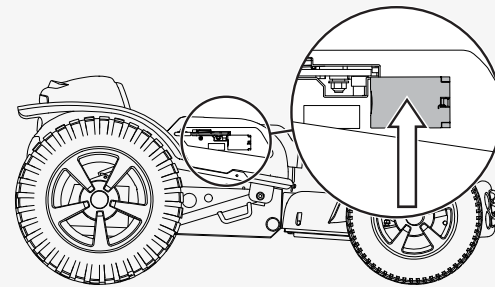

4.5.1 Entering freewheel mode

1. Make sure that the wheelchair is on level ground.
2. Turn off the wheelchair.
3. Press down lever **A** to release the safety catch and move the lever forwards (**B**).

4.5.2 Exiting freewheel mode

1. Turn off the wheelchair.
2. Move the lever backwards to its end position.

4.6 Vehicle transportation

This chapter describes how you transport your wheelchair in a vehicle. The wheelchair must only be transported in vehicles approved for this purpose.

4.6.1 Securing the wheelchair in a vehicle

This chapter describes how you secure the wheelchair in a vehicle. You must secure the wheelchair at its tie-down points.

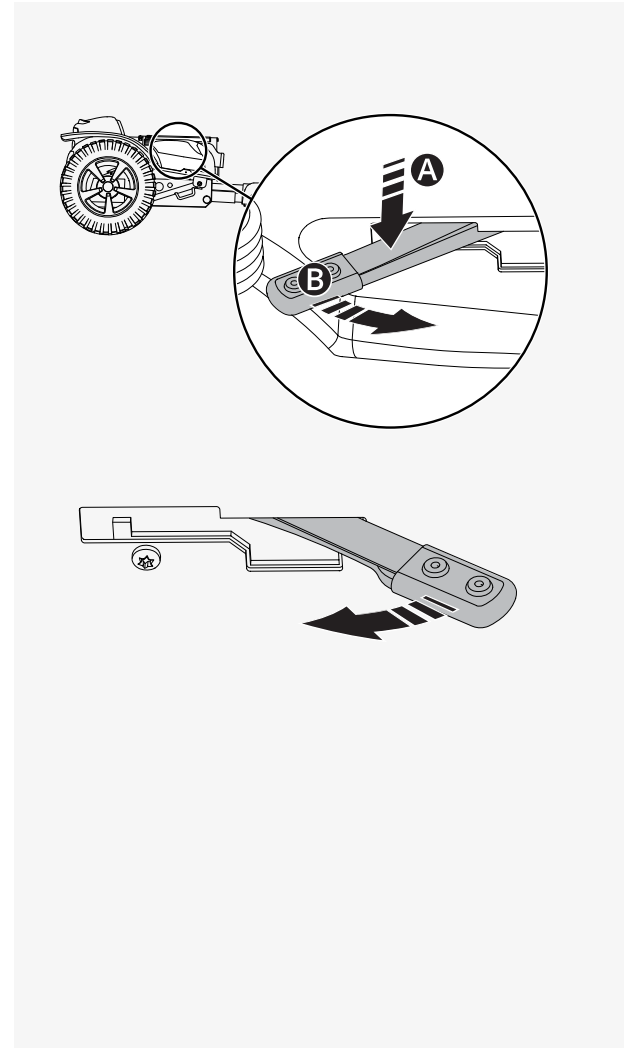

Remove loose objects, trays and other auxiliary equipment from your wheelchair and store them safely before you transport your wheelchair in a motor vehicle. If you transport a wheelchair in a motor vehicle with loose objects, trays or other auxiliary equipment, the vehicle's occupants could suffer bodily injury.

This is how you secure the wheelchair at its tie-down points. Make sure that the wheelchair is properly secured and that the wheelchair is not in freewheel mode. Secure the wheelchair with straps at the tie-down points. The tie-down points are marked with yellow labels (A).

Make sure that strap (A) is positioned on top of the front axle (B) of the wheelchair. After you have secured the straps to your wheelchair, secure the other end of the straps to your vehicle according to the appropriate instructions. The end-fitting on the strap must comply with ISO 10542-1:2012, which is an international standard that governs wheelchair tie-downs and occupant-restraint systems. Every vehicle tie-down system is different, and it is important that you follow the instructions for your particular vehicle system. To make transportation of the wheelchair easier, you can remove or fold down the backrest. This is done in a few simple moves. See page 44. If necessary, you can also remove the headrest. See page 41.

4.6.2 Using the wheelchair as a seat in a vehicle

Permobil recommends that, whenever feasible, you transfer to a vehicle seat and that you use the vehicle's restraint systems. The unoccupied wheelchair should be stored in a cargo area or secured in the vehicle during travel. Follow the instructions below if you want to use the wheelchair as a seat in a vehicle.



WARNING! Positioning aids do not replace seatbelts

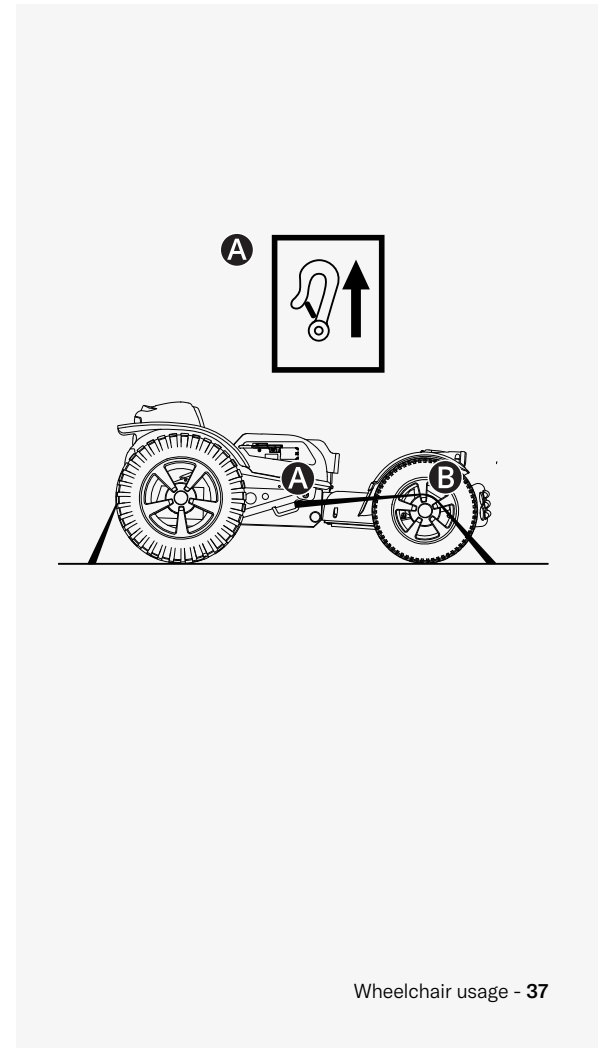



WARNING! Vehicle seating requirements

The wheelchair should be forward-facing when you use it as a seat in a vehicle. Permobil has no manufacturer-designated wheelchair-mounted belt restraints. Use the vehicle's restraint systems.

You must use both pelvic-belt restraints and shoulder-belt restraints. Pelvic and shoulder-belt restraints should be used together as designed.

Make sure that the belt restraints are as tight as possible, without becoming uncomfortable, and that they are not twisted. They must be close to your body and not held away by parts of the wheelchair. Adjust your restraint system such that the release mechanisms cannot be pressed during a crash.

The shoulder-belt restraint should be worn over the middle of the shoulder. The pelvic-belt restraint should be in contact with and worn low across the pelvis and within the preferred zone of 30° to 75°. A steeper pelvic-belt angle between 45° to 75° to the horizontal is preferred. Make sure that the wheelchair is not lifted or tilted. The wheelchair must be in the position shown in the illustration.

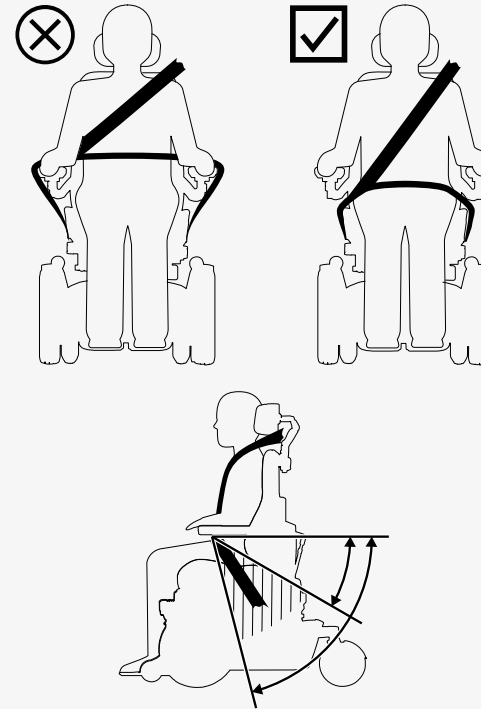

4.7 Air transportation

This chapter contains information that may be helpful if you are transporting your wheelchair by air.

4.7.1 Batteries

The main circuit breaker must always be in the off position. In most cases, gel batteries do not have to be removed from the wheelchair.

4.7.2 Weight and dimensions

Contact the relevant airline for applicable rules on weight and dimensions for your power wheelchair.

4.7.3 Preventing damage to wheelchair

Since the wheelchair will be put with other goods in a confined space during the flight, it is important to take preventive measures to minimise transportation damage to the wheelchair.

Cover the control panel and other sensitive objects with soft, shock-absorbing material (foam plastic or similar). Push the control panel toward the backrest. Tape any loose cables to the seat or hoods.

4.8 Rail transportation

Regulation (EU) 1300/2014 concerns the interoperability of the European rail network. A part of this regulation contains limits for weights and dimensions. Your wheelchair may deviate from the weight limits and from the dimension limits specified.

4.9 Main circuit breaker

Your wheelchair has a main circuit breaker with two functions. You can use it to turn off the main power, for example before you transport the wheelchair. It also trips if there are any issues with the circuits.

The first time the main circuit breaker trips, you can reset it yourself. If it trips again, contact your service technician.

Lift the rubber cover next to the main circuit breaker label. Flip the switch to turn on and off or to reset the main circuit breaker. Always turn off the control panel before you turn off the main circuit breaker.

4.10 Wheelchair storage

You can store your wheelchair for a short or long period of time.

When you store it for a short time, make sure that the room is dry and not colder than 5°C (41°F). If the temperature is lower, the batteries might not charge fully. They are also more vulnerable to corrosion.

When you store it for a long time, fully charge the batteries before storage. Remember to switch off the main circuit breaker. Charge the batteries every month. You will need to switch on the main circuit breaker to charge the batteries, then switch off the main circuit breaker if the wheelchair is to remain in storage.

4.11 Manual adjustments

The wheelchair may have functions that are adjusted manually. Available functions vary depending on the equipment fitted on your wheelchair.

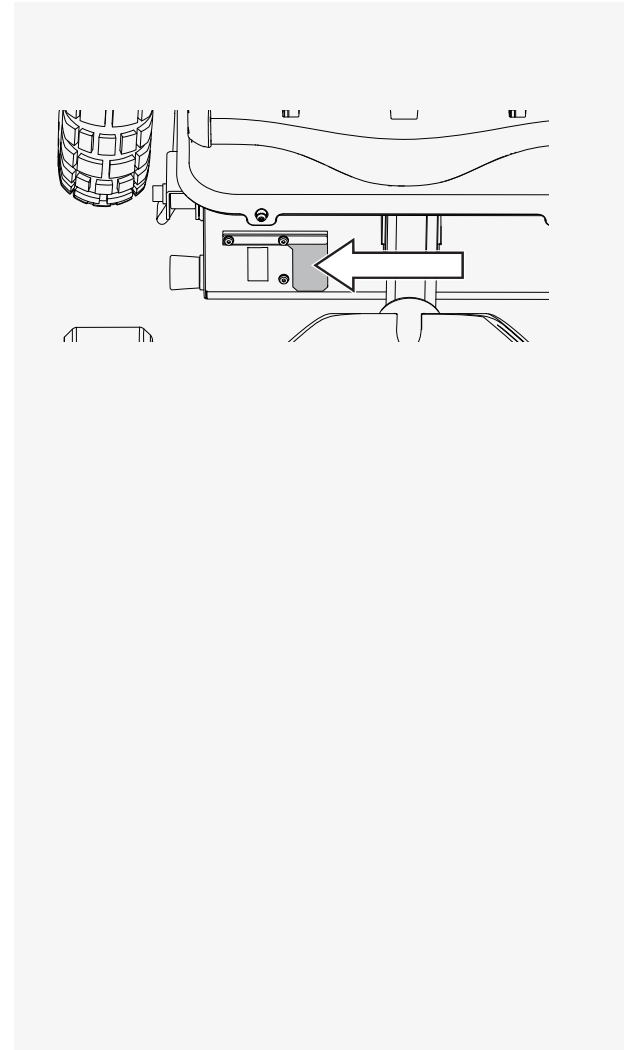

4.11.1 Headrest

This chapter shows you how to adjust the height, depth, and angle of the headrest. It also shows you how to remove and install the headrest. Do not put any weight on the headrest while you adjust it. If you do, you may damage it.

This is how you adjust the height and depth of the headrest.

1. Loosen the handle **A** on the backrest.
2. Adjust the height or depth to the preferred position.
3. Tighten the handle **A**.

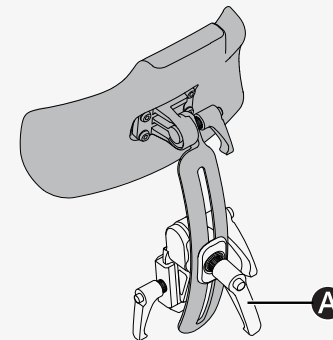
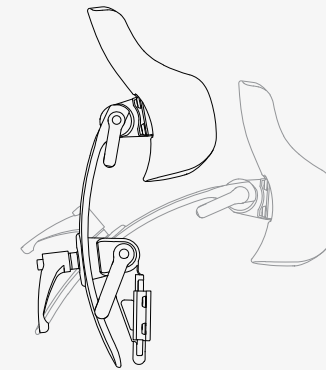

This is how you adjust the angle of the headrest.

1. Loosen the handle **B** on the rear of the headrest.
2. Adjust the headrest angle to the preferred position.
3. Tighten the handle **B**.

This is how you remove and install the headrest.

1. Loosen the handle **C** on the backrest.
2. Lift the headrest straight up.

Install the headrest in the reverse order. You can remove and install the headrest without affecting current settings.

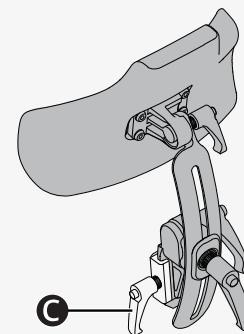
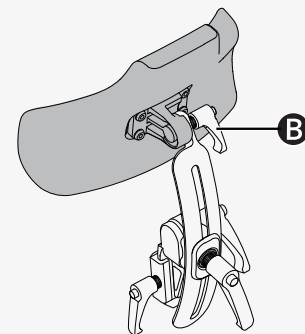

4.11.2 Backrest tilt

You can adjust the backrest to several fixed positions. Do not put any weight on the backrest while you adjust it.

This is how you adjust the backrest.

1. Hold the backrest and pull out the handle **A** of the quick-acting lock so that the locking tube moves freely.
2. Adjust the backrest angle to the preferred position.
3. Release the handle **A** to lock the locking tube.
4. Make sure that the backrest is locked in position.

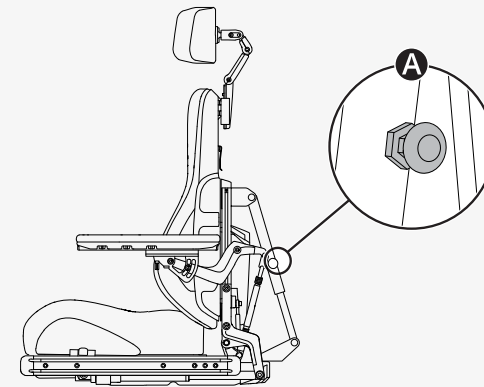

4.11.3 Removing the backrest

You can remove the backrest to make transportation of the wheelchair easier. First, remove backrest cushion **A**. It is attached with Velcro. Then carefully undo the clip **B** on the backrest and pull the upper part of the backrest straight up **C**.

If necessary, you can also remove the headrest. See 4.11.1 *Headrest*, page 41.

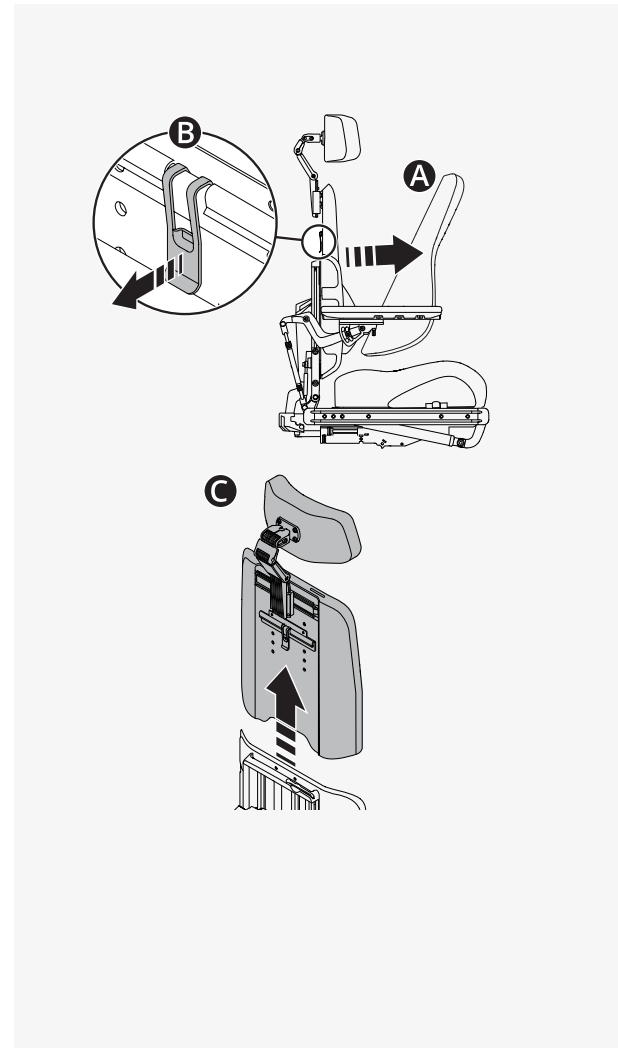

4.11.4 Armrest

This chapter shows you how to adjust a swivelling armrest and how to adjust armrest height and armrest angles.

4.11.4.1 Swivelling armrest

This chapter describes how you adjust a swivelling armrest. A swivelling armrest is an armrest that you can push in or out as preferred between certain settings. There are three swivel settings (**B**, **C**, and **D**) and one locked setting (**A**).

Swivel settings		
A	Factory setting	Locked
B	Factory setting	0° to +15°
C	Custom setting	-15° to +15°
D	Custom setting	0° to +30°

This is how you change the swivel setting.

🔑 Allen key 5 mm

1. Fold up the armrest.
2. Remove the screws from the current setting.
3. Insert and tighten the screws in the preferred setting.
4. Fold down the armrest.

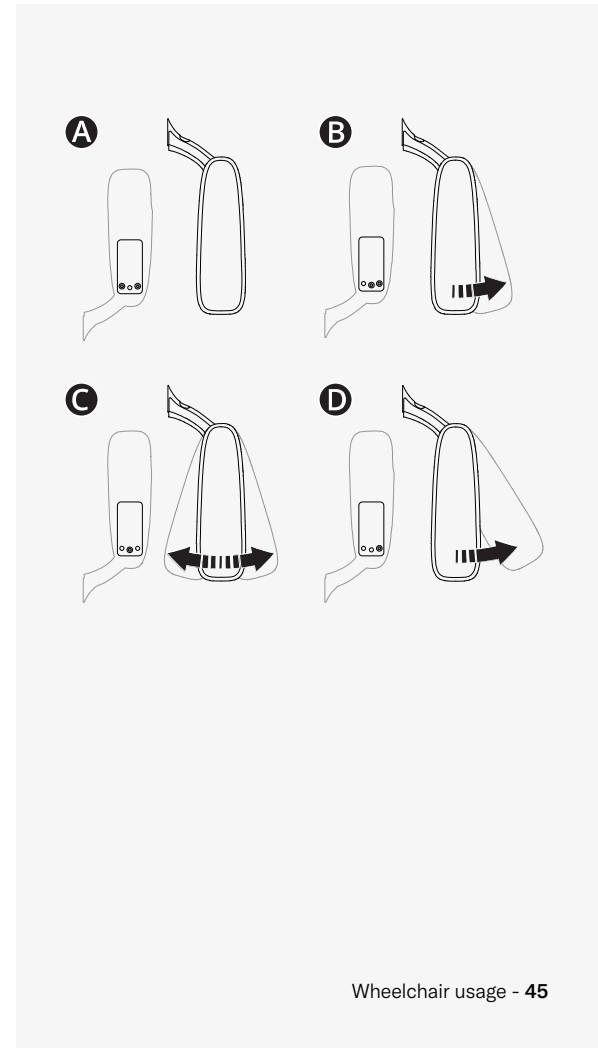

4.11.4.2 Armrest height and armrest angles

This chapter shows you how to adjust the height of the armrest and the angles of the armrest. There are two ways to adjust the armrest angle.

This is how you adjust the height of the armrest. You can see the current height of the armrest on the backrest. The adjustment crank is located in the backrest.

🔑 Allen key 5 mm

🔑 Adjustment crank

1. Loosen the four screws **A** on the backrest.
2. Remove adjustment crank **B**.
3. Use the adjustment crank to turn the adjustment screw **C** until the armrest is in the preferred position.
4. Tighten the four screws on the backrest.

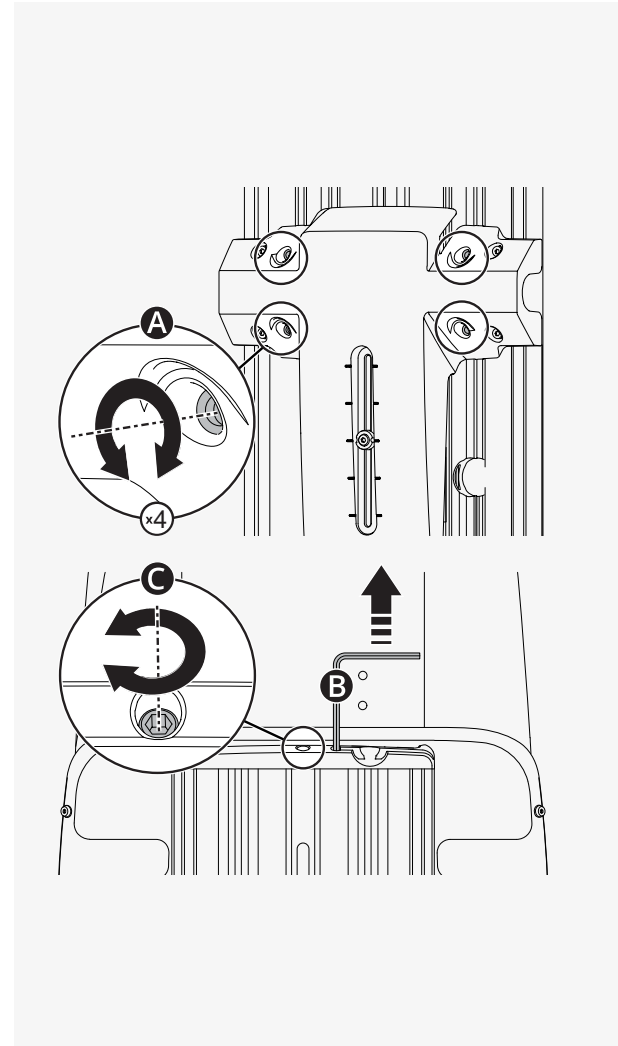

This is one way to adjust the angle of the armrest. The lower lock nut has a left-hand thread.

🔧 Spanner 14 mm

1. Loosen the two lock nuts **A** on the adjustment bar **B**.
2. Turn the adjustment bars to adjust the armrest angle to the preferred position.
3. Tighten the two lock nuts.

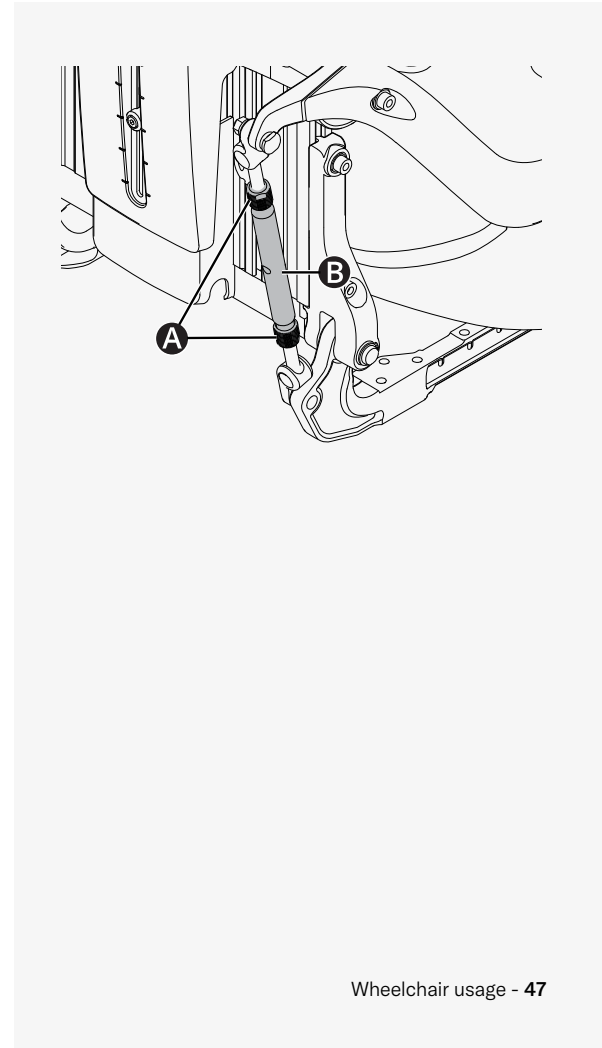

This is the other way to adjust the angle of the armrest.

🔑 Allen key 5 mm

1. Move the screw from fixed position **A** to flexible position **B**.
2. Adjust the armrest angle to the preferred position.
3. Tighten screw **B**.

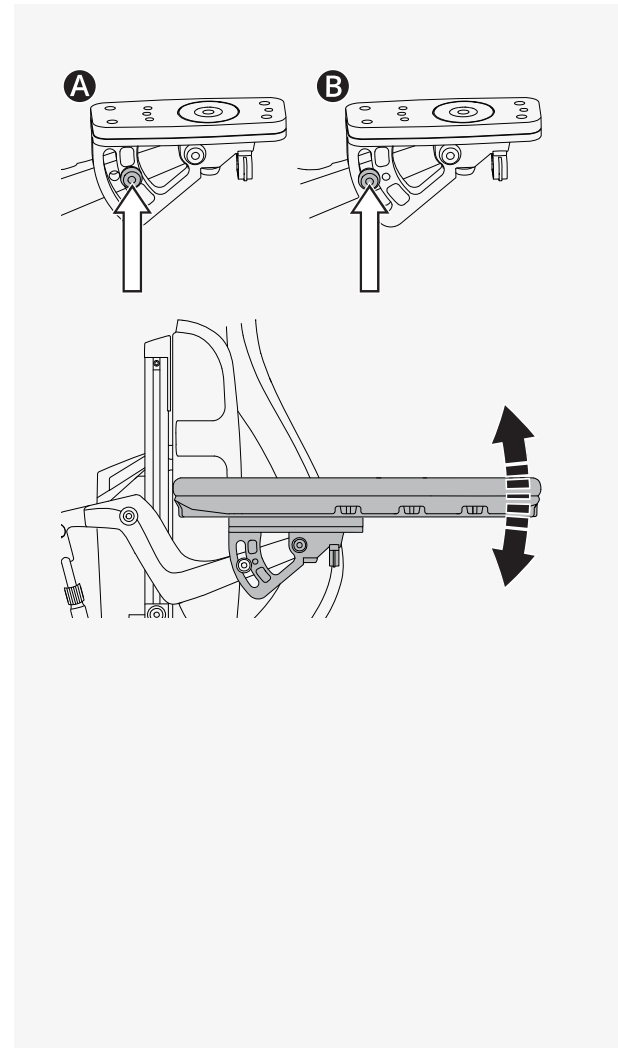

4.11.5 Lumbar support

This chapter shows you how to adjust the lumbar support. The lumbar support consists of three cushions with Velcro. If you want to adjust it, simply remove the backrest cushion and adjust the lumbar support as preferred.

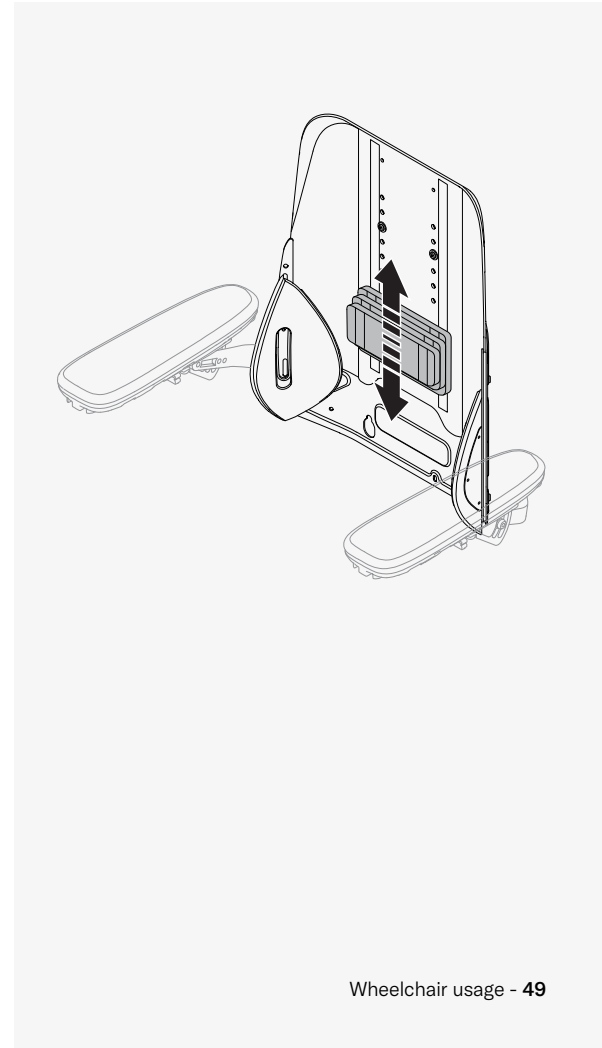

4.11.6 Trunk support

This chapter shows you how to adjust the height of the trunk support.

This is how you adjust the height of the trunk support.

🔑 Allen key 5 mm

1. Remove the backrest cushion.
2. Loosen the screw **A** on the backrest that holds the trunk support in place.
3. Adjust the trunk support **B** to the preferred position.
4. Tighten screw **A**.
5. Put back the backrest cushion.

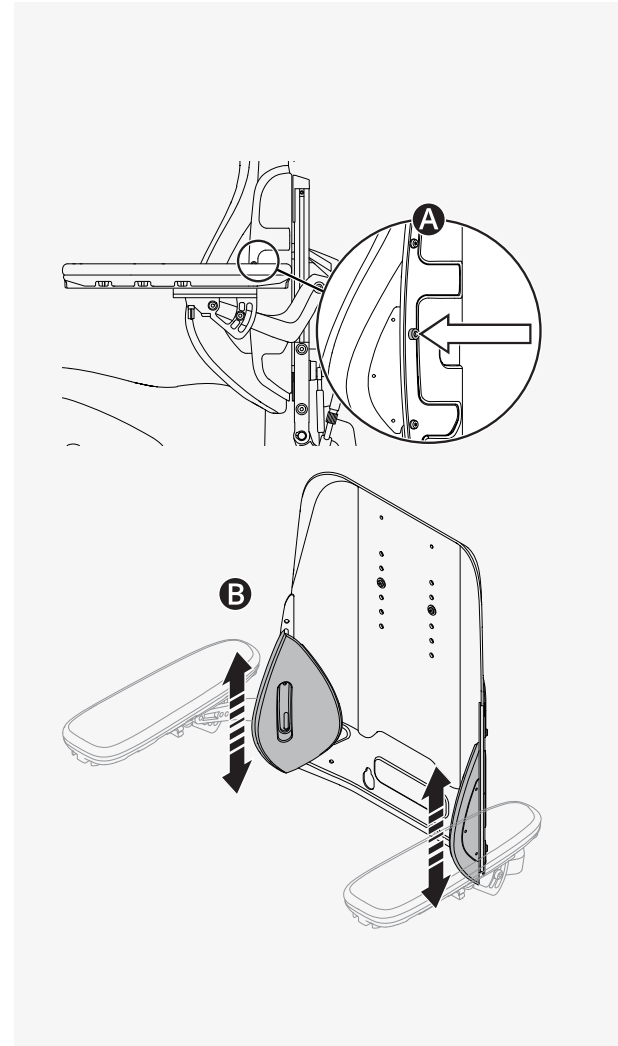

4.11.7 Rotational panel holder

You can adjust the distance between the armrest and the control panel, the resistance of the rotational panel holder, and the angle of the rotational panel holder.

This is how you adjust the distance between the armrest and the control panel.

🔑 Allen key 5 mm

1. Loosen screw **A** on the panel joint.
2. Adjust the control panel to the preferred position.
3. Tighten the screw.

This is how you adjust the resistance of the rotational panel holder.

Loosen or tighten knob **A** on the friction joint to adjust how easily the rotational panel holder can be pushed to either side.

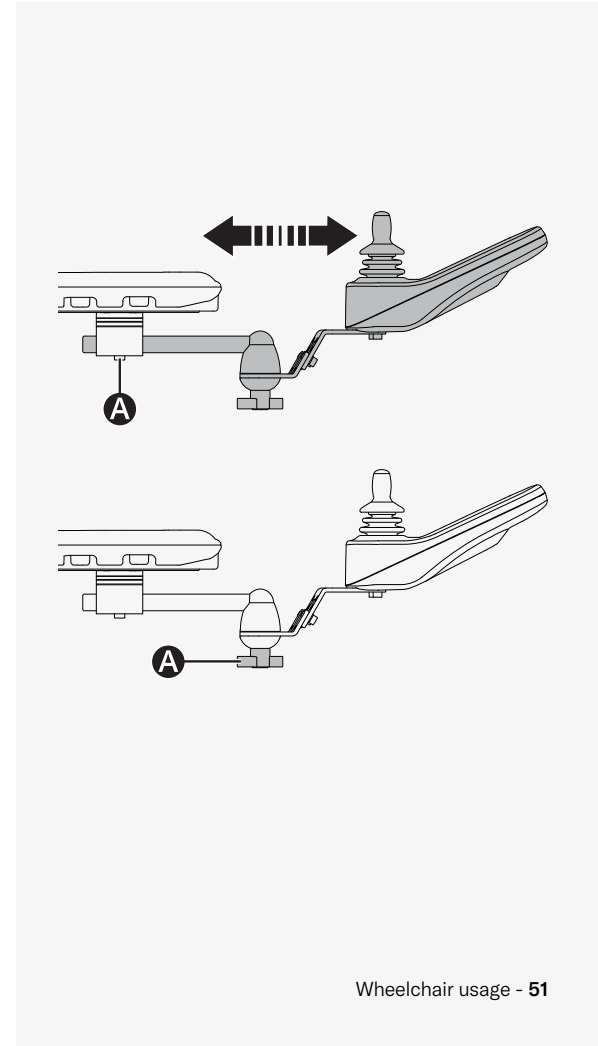

You can angle the rotational control panel to either side. This is how you adjust the angle.

🔑 Allen key 4 mm

1. Remove screw **A** on the side you want to angle.
2. Loosen the other screw **A**.
3. Adjust the angle of the panel **B** to the preferred position.
4. Tighten the two screws.

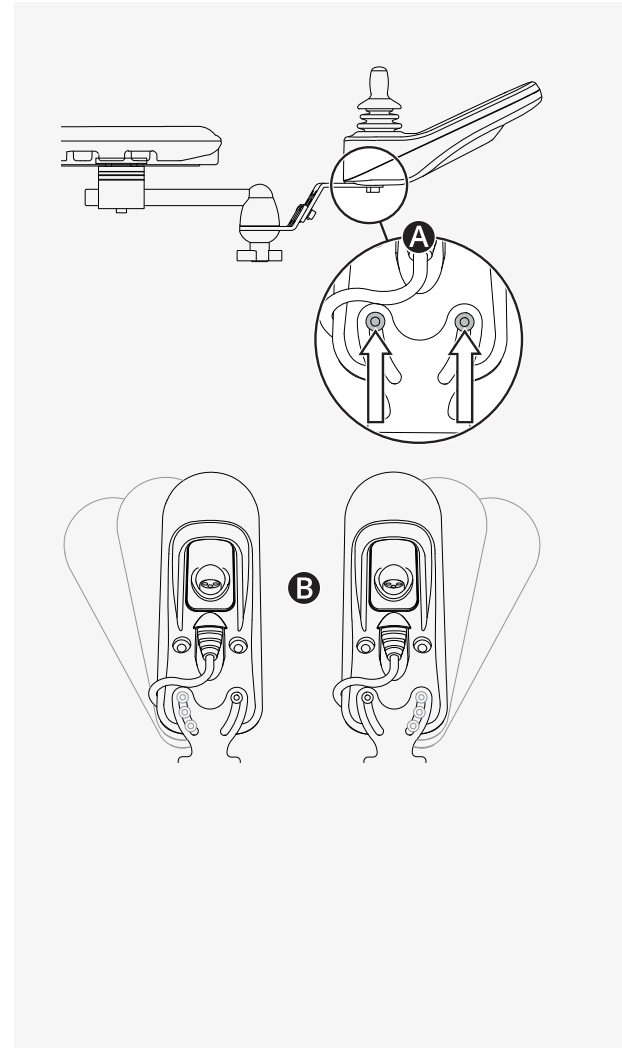

4.11.8 Parallel panel holder

You can adjust the distance between the armrest and the control panel. It is also possible to adjust the angle of the control panel.

This is how you adjust the distance between the armrest and the control panel. Leave a gap of at least 10 mm (0.4") between the armrest and the control panel.

- ✚ Torque wrench
- ✚ Allen key 5 mm

1. Loosen screws **A** enough to slide the panel holder.

2. Adjust the panel to the preferred position.
3. Torque the screws to 9.8 N m (7.2 lb-ft).

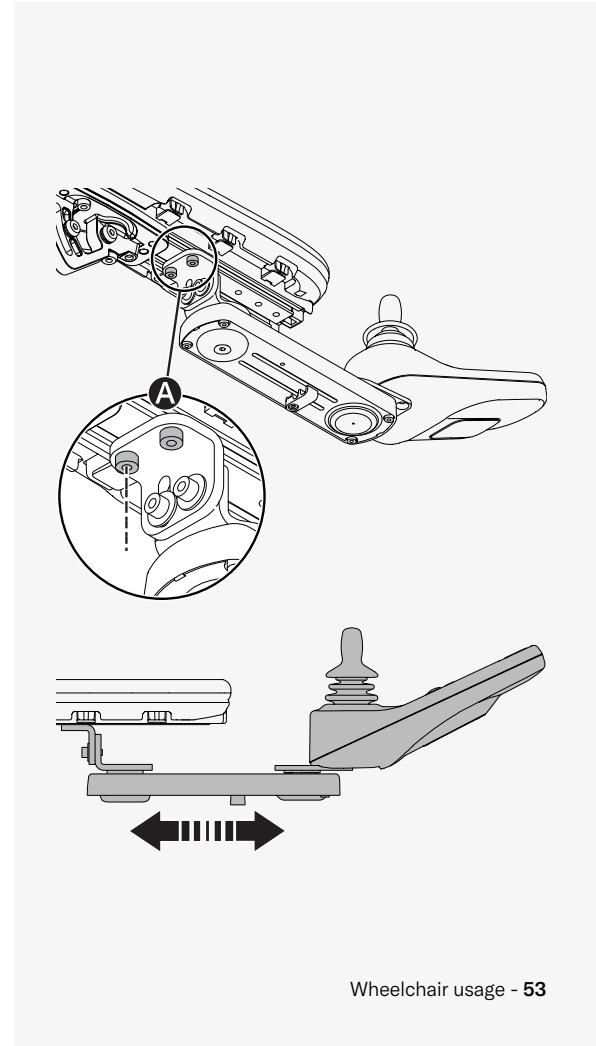

This is how you adjust the angle of the control panel.

🔑 Allen key 4 mm

Slide the panel to the preferred position. You can loosen or tighten screw **A** to adjust the resistance.

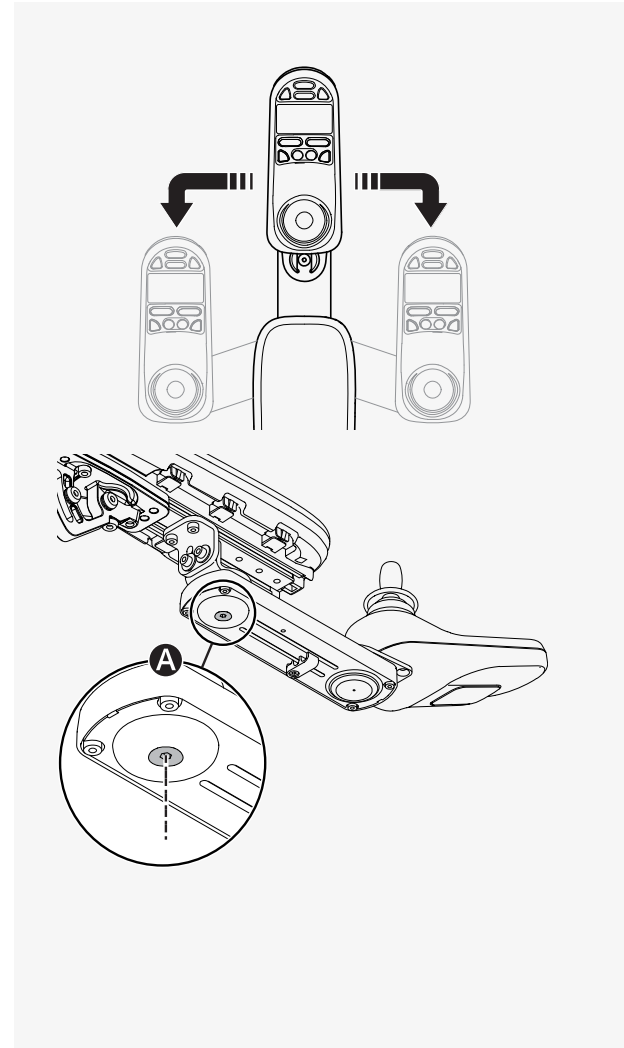

4.11.9 Positioning belt

Always wear your positioning belt. There is an accessory rail on each side of the seat frame, for example, for attaching a positioning belt.

🔧 Spanner 10 mm

1. Screw the positioning belt in place in the rail's upper groove.
2. Make sure that the belt buckle locks properly in the snap lock.

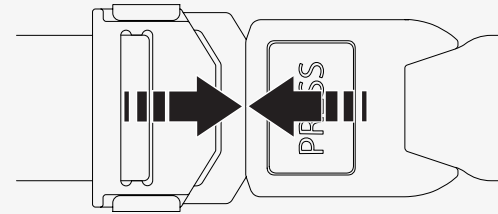
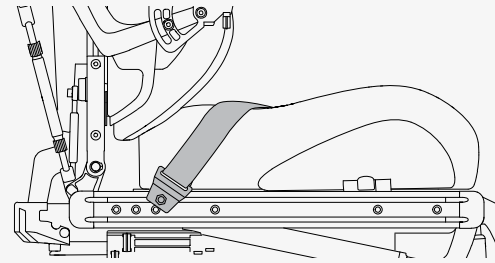

4.11.10 Footplate extension

You can adjust the distance ① between the footplate and the seat. The maximum distance is 200 mm (7¾ inches).

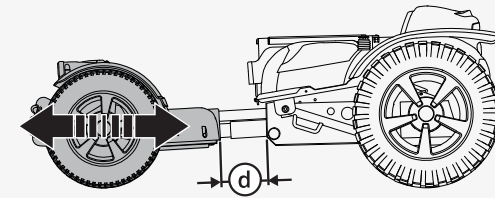

Put the adjustment rod in the preferred position. The measurements below indicate the distance between the centre of the front and rear wheels.

Settings

- Ⓐ to ⓓ = 815 mm
- Ⓑ to ⓓ = 850 mm
- Ⓒ to ⓓ = 885 mm
- Ⓓ to ⓓ = 910 mm
- Ⓔ to ⓓ = 945 mm
- Ⓔ to ⓖ = 980 mm
- Ⓔ to ⓕ = 1015 mm

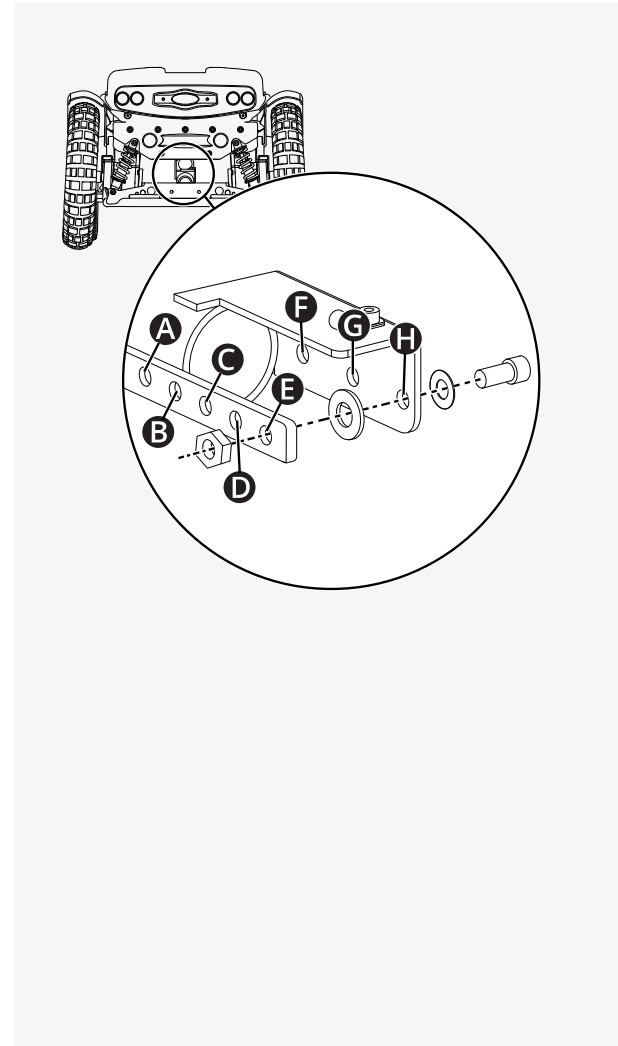

5 Maintenance

For the wheelchair to work well, it is important that you use it correctly and maintain it regularly. A well maintained wheelchair lasts longer and has a lower risk of defects. Only carry out maintenance and minor adjustments that are specified in the user manual. All other maintenance, service and repairs must be carried out by a qualified service technician authorised by Permobil.

5.1 Maintenance and inspection schedule

Permobil recommends compliance with the following maintenance and inspection schedule. Contact your authorised dealer for all service-related needs or questions.

Maintenance and inspection schedule	Daily	Weekly	Monthly	Yearly
Check battery level indicator and charge the wheelchair if necessary.	×			
Make sure that the joystick panel and other control panels are not damaged.	×			
Make sure that all removable parts are securely fastened.	×			
Check positioning belts for wear and make sure buckles work.	×			
If the wheelchair is equipped with pneumatic tyres, check the tyres and inflate as necessary.		×		
If the wheelchair is equipped with lights and indicators, make sure that they are operational and clean.		×		
Clean the wheelchair and upholstery.			×	
Check upholstery, seating, and postural supports for wear.			×	
Check that the freewheel mode and the freewheel lever work properly.			×	
Complete inspection, safety check, and service performed by an authorised wheelchair dealer.				×

5.2 Cleaning

Regular care and maintenance will prevent unnecessary wear and damage to your Permobil product. Turn off the power before you clean the wheelchair.

5.2.1 Metal surfaces

Due to the high quality powder coating, optimum corrosion protection is guaranteed. Ideally, use a soft cloth or sponge, hot water, and a mild detergent for normal cleaning. Wipe down carefully with a cloth and water, and dry off.

Remove scuff marks from semi-matt surfaces using soft wax. Follow the instructions provided by the manufacturer of the soft wax.

Remove scuff marks and scratches from shiny surfaces with car polish. You can use either liquid or paste car polish. After you have polished, apply soft car wax to restore the original surface gloss.

5.2.2 Plastics

For normal cleaning, wash plastic surfaces with a soft cloth, mild detergent, and hot water. Rinse thoroughly and dry with a soft cloth. Do not use solvents or abrasive kitchen cleaners.

5.2.3 Upholstery, cloth, and vinyl

For normal cleaning, wash the upholstery with lukewarm water and a mild, non-abrasive soap. Use a soft cloth or brush. Wipe off any water or soapy water residues with a clean, dry cloth. Let the surface dry. Repeat this procedure to remove stubborn dirt or stains. Ink spots can sometimes be removed with soap and water followed by isopropyl alcohol.

Do not use any other cleaning methods than those listed here. Other cleaning methods may attack and degrade the vinyl and may also void the wheelchair's guarantee.

If necessary, you can remove the cover before cleaning. See also the washing instructions on the upholstery materials.

5.3 Inflating the drive wheel tyres

Only drive the wheelchair with the correct tyre pressure. The tyre pressure for the drive wheel tyres is 250 kPa (35 psi). Permobil recommends that you check the tyre pressure weekly and after any significant change in temperature or altitude.

Incorrect tyre pressure may make the wheelchair unstable and difficult to drive. It may also result in abnormal wear, punctures, a shorter driving range, and damage to the wheel assembly.

This is how you inflate the drive wheel tyres.

1. Unscrew and remove the valve cap from the tyre air valve.
2. Connect the compressed air nozzle to the valve and adjust the tyre pressure to the prescribed level.
3. Put the valve cap back.

5.4 Positioning belt

Check the condition of the positioning belt regularly in case any damage or wear has occurred. If signs of damage or wear appear, replace the positioning belt immediately through your Permobil dealer.



6 Troubleshooting

The following troubleshooting guide describes a number of faults and events that can occur when you use the wheelchair, together with suggested remedies.

Note that the guide cannot describe all the problems and events which may occur and you should always contact your service provider or Permobil technical support if you need additional assistance. Troubleshooting and repairs of electronics must always be performed by qualified personnel with good knowledge of the wheelchair's electronics.

6.1 Troubleshooting guide

Event	Possible cause	Remedy
The wheelchair does not start.	The batteries are discharged.	Charge the batteries.
	The cable connection to the control panel has come loose.	Insert the cable in the control panel.
	The main circuit breaker is turned off.	Turn on the main circuit breaker. See page 40.
	The main circuit breaker has tripped.	Reset the main circuit breaker once. See page 40.
The wheelchair cannot be charged.	The main circuit breaker is turned off.	Turn on the main circuit breaker. See page 40.
	The charging circuit breaker has tripped.	Contact your service provider or Permobil technical support for assistance.
The wheelchair cannot be driven.	The battery charger is connected.	Disconnect the battery charger.
	The wheelchair is in freewheel mode.	Exit freewheel mode and restart the wheelchair.
	The wheelchair is locked.	Unlock the wheelchair.
	The motors have become too warm.	Turn off the wheelchair and wait for the motors to cool down.

Event	Possible cause	Remedy
The wheelchair switches itself off after a certain period of inactivity (20–30 minutes).	The energy saving mode has been activated.	Press the start button on the control panel to turn on the wheelchair again.
The wheelchair stops while being driven.	The main circuit breaker has tripped.	Reset the main circuit breaker once. See page 40.

6.2 Error codes

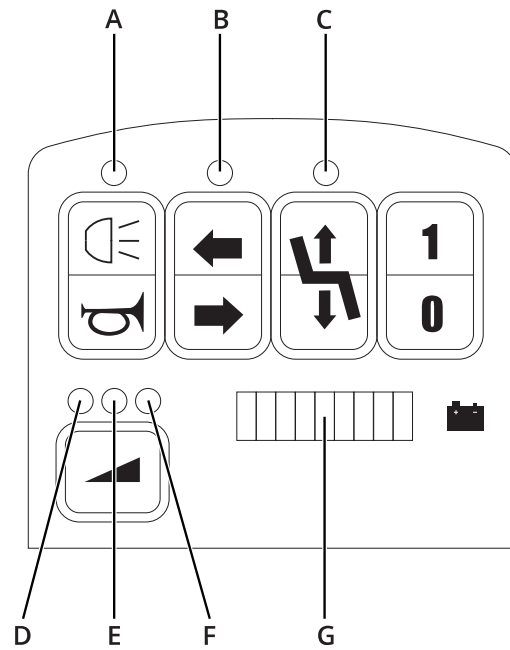

- A. Indicator light 1
- B. Indicator light 2
- C. Indicator light 3
- D. Indicator light 4
- E. Indicator light 5
- F. Indicator light 6
- G. Battery indicator

This chapter describes six error codes and their remedies.

Low battery voltage. Error code: two red dashes on the battery indicator flash and six short beeps are repeated at intervals of two minutes when the joystick is activated.

Remedy: Recharge the batteries as soon as possible.

Critical battery voltage. Error code: one red dash on the battery indicator flashes and a continuous beep is heard when the joystick is activated. The wheelchair cannot be driven.

Remedy: Turn the wheelchair off/on. The wheelchair can be driven a shorter range before recharging the batteries.

Parking brake released or joystick deflected at start-up. Error code: The entire battery indicator flashes and short beeps are heard when the joystick is activated.

Remedy: Make sure that the parking brake is released. Restart the wheelchair.

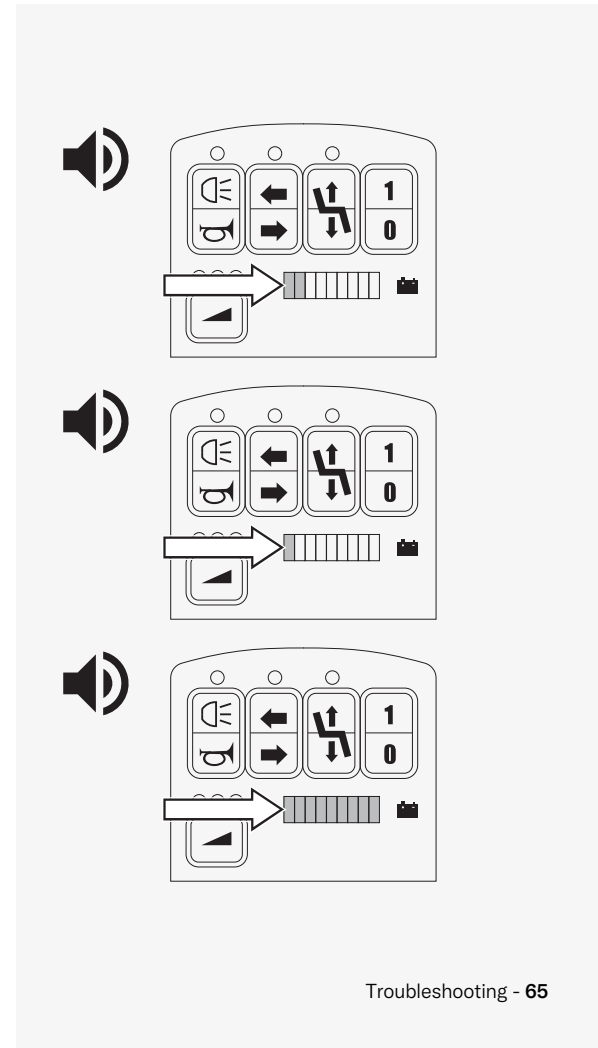

Seat rotation out and seat lift pinch protection active Error code: LED 3 flashes. If pinch protection is active, the seat lift cannot be lowered.

If the seat rotation is out, the wheelchair cannot be driven.

Remedy: Check if the seat rotation is out or contact your service technician.

Warm motors or hot motors. Error code: LEDs 4–6 flash, depending on the current maximum speed setting.

Warm: six short beeps at intervals of two minutes when the joystick is activated.

Hot: Continuous beeps for ten seconds.

Remedy: Turn off the wheelchair and wait for the motors to cool down.

Warm electronics. Error code: LEDs 4–6 flash, depending on the current maximum speed setting. Six short beeps at intervals of two minutes.

The wheelchair's driving power is reduced. If you drive on a hill, the reduced driving power can cause the wheelchair to stop or roll slowly downhill. The ability to brake remains the same and the wheelchair stops when you let go of the joystick.

Remedy: Turn off the wheelchair.

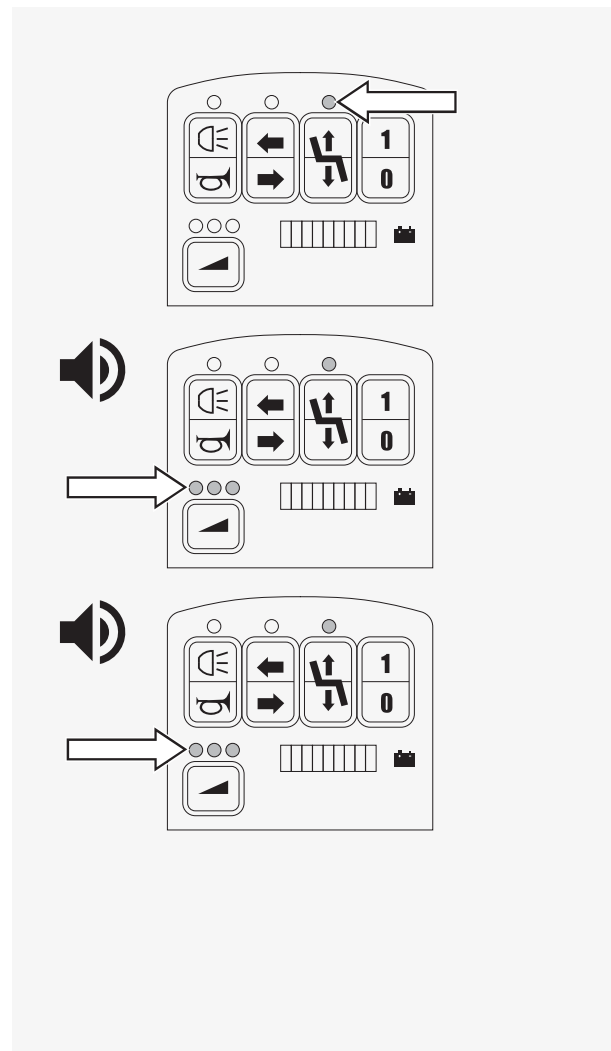

7 General information

This chapter contains information about warranty, standards and regulations, reporting incidents, scrapping and recycling, and technical specifications.

7.1 Guarantee

All power wheelchairs are supplied with a two-year product guarantee. Batteries and chargers are supplied with a one-year guarantee.

Product Guarantee Information sets forth the conditions of the guarantee. For further information about applicable guarantees, see <https://permobilus.com/support/warranties/>.

7.2 Standards and regulations

This product fulfils the following requirements:

- Electrically powered wheelchairs, scooters and their chargers – Requirements and test methods (EN 12184)
- Wheelchair standard series ISO 7176
- U.S. Food and Drug Administration's regulation 21 CFR 820
- Medical Device Regulation (EU) 2017/745

7.3 Reporting incidents

If a serious incident occurs, you must contact a competent authority or Permobil by phone or email.

7.4 Disposal and recycling

Contact Permobil for information about disposal agreements in force.

7.5 Technical specifications

Mass of the heaviest part	Backrest 15 kg (32 lb)
Reversing width	1920 mm (6.3 ft)
Minimum turning diameter	3460 mm (11.6 ft)
Required width of angled corridor	1060 mm (3.5 ft)
Required doorway entry depth	2300 mm (7.5 ft)
Required corridor width for side opening	2100 mm (6.9 ft)
Ground clearance	100 mm (4")
Ability to negotiate obstacles (approach distance 0 cm [0"])	75 mm (3")
Ability to negotiate obstacles (approach distance 50 cm [20"])	100 mm (4")
Ability to negotiate obstacles (driving forwards)	110 mm (4.3")
Battery cycle life	300 cycles
Battery type and nominal voltage	Sealed lead acid, 2 x 12 V, group 31
Occupant mass group	III
Maximum speed (forwards on horizontal)	15 km/h (9.3 mph)
Theoretical continuous driving distance range ¹	40 km (25 miles)

1. Actual driving range will vary based on driving conditions, battery conditions, and terrain.

How to contact your production unit

Timrå, Sweden

 PU TIM
Permobil AB
Per Uddéns väg 20
SE 861 36 Timrå
Sweden

 +46 60 59 59 00

 +46 60 57 52 50

 info@permobil.com

 www.permobil.com

Nashville, USA

 PU NAS
Permobil Inc.
300 Duke Drive
Lebanon, TN 37090
USA

 +1 800 736 0925

 +1 800 231 3256

 support@permobil.com

 www.permobil.com

How to contact your local office

Greece, Hungary, Iceland, Israel, Poland, Saudi Arabia, South Africa, Turkey, United Arab Emirates

 Permobil AB
Per Uddéns väg 20
SE 861 36 Timrå
Sweden

 +46 60 59 59 00

 info@permobil.com

 www.permobil.com

 PU TIM

Ireland and United Kingdom

 Permobil Ltd.
Unit 7, Polaris Centre, 41 Brownfields
Welwyn Garden City, Herts, AL7 1AN
United Kingdom

 +44 1484 722 888

 +44 1484 723 013

 info@permobil.uk

 www.permobil.com

 PU TIM

Hong Kong and Taiwan

 Permobil
No.128 Tian Mu Road West/
上海市静安区天目西路128号
Shanghai
China

 +86 4000 178 179

 info.apac@permobil.com

 www.permobil.com

 PU TIM

India, Malaysia, Singapore, Thailand

 Permobil
8 Viewbrook Close
Seven Hills, NSW, 2147
Australia

 +61 1300 845 483

 info.apac@permobil.com

 www.permobil.com

 PU TIM

South Korea



Permobil Korea
2 Floor, Simon-Tower 15 Teheran-ro 84-gil,
Gangnam-gu
Seoul, 06179
South Korea



+82 2566 2 020



contact.korea@permobil.com



www.permobil.com



PU TIM

Dealer's address and telephone number

permobil

334065 eng-UK



www.permobil.com