

# PRODUCT SPECIFICATIONS SHEET

Model: Jazzy Air®

Document Information: INFINF B3432/Rev C/April 2016

Class of Use <sup>7</sup>	B
Weight Capacity	300 lbs. (136 kg/21 stone 6 lbs.)
Maximum Speed <sup>1</sup>	Up to 4 mph (6.44 km/h) Up to 3.5 mph (5.6 km/h) with Jazzy Air feature elevated
Ground Clearance <sup>2</sup>	2.42 in. (61.5 mm) at footplate bracket in lowest position 1 in. (25.4 mm) at motor bracket
Turning Radius <sup>2</sup>	22.5 in. (571.5 mm)
Overall Size <sup>2, 6</sup>	Length: 43.2 in. (1100 mm) with front rigging 38.6 in. (980 mm) without front rigging Width: 25.5 in. (650 mm)
Drive Wheels	10 in. (254 mm), flat free
Caster Wheels	6 in. (152.4 mm), flat free
Suspension	Active-Trac® with Mid-Wheel 6 Technology
Range <sup>1, 4</sup>	Up to 18.4 miles (29.64 km) with 40 Ah batteries Up to 15.3 miles (24.6 km) with U-1 batteries
Component Weights <sup>5</sup>	Complete Assembly (without batteries): 181 lbs. (82 kg) Batteries: U-1: 24.5 lbs. (11.1 kg) each; 40 Ah: 32.2 lbs. (14.6 kg) each
Drivetrain	Two motor, mid-wheel-6 drive
Brakes	"Intelligent Braking" electronic regenerative, disc park brake
Batteries <sup>3</sup>	Two 12 volt, deep-cycle U-1; 40 Ah
Battery Charger	3.5 amp, off-board
Freewheel Operational Force	Less than 60 N
Drive Control Operational Force	Less than 5 N
Maximum Rated Slope	6° (10.5%)
Maximum Obstacle Climbing Ability (Ascending and Descending)	2.2 in. (56 mm) 1.8 in. (46 mm) with Jazzy Air feature elevated
Measured Sound Level (A-weighted)	Less than 65 dB

- <sup>1</sup> Varies with base model, user weight, terrain type, battery amp hour rating (Ah), battery charge, battery condition, motors, controller type, tire type, and tire condition. This specification is subject to a variance of +10%, -5%.
- <sup>2</sup> Due to manufacturing tolerances and continued product improvement, this specification can be subject to a variance of (+ or -) 3%.
- <sup>3</sup> AGM or Gel-Cell type required. See "Batteries and Charging."
- <sup>4</sup> Tested in accordance with ANSI/RESNA, WC Vol. 2, Section 4 & ISO 7176-4 standards. Results derived from theoretical calculations based on battery specifications and drive system performance. Test conducted at maximum weight capacity.
- <sup>5</sup> Battery weight may vary based on manufacturer.
- <sup>6</sup> Dimensions listed are for power base only. Overall measurements will vary based on seating and accessory selections.
- <sup>7</sup> Using 40 Ah batteries.

**NOTE: This product conforms to all applicable ANSI/RESNA, ISO 7176 Series, AS/NZS 3695.2, and EN12184 standards. All specifications subject to change without notice.**



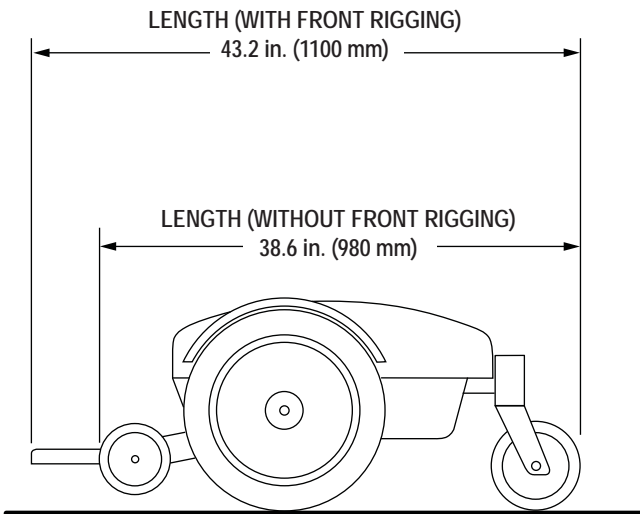

TURNING RADIUS

