



SERVICE MANUAL

**ENGLISH**



# SERVICE MANUAL

## TEKNA TILT

Adult and Junior

Rev. 0 - 06/05/2020



**progeo**  
ACTIVE DESIGN



# TEKNA TILT

## Adult and Junior

### GENERAL WARNINGS

ANY ADJUSTMENT CAN BE CARRIED OUT EXCLUSIVELY BY QUALIFIED AND AUTHORIZED BY REHATEAM® PERSONNEL.

It is forbidden to carry out any modifications, even when possible, to the original design.

Any adjustments and/or any modification that is carried out by non-authorized personnel will immediately void the warranty on the product and it relieves RehaTEAM® from any responsibility on any malfunctioning and/or damage due to such adjustments/modifications.

Always contact RehaTEAM® and its technicians for any non-standard requirements or modifications to allow them to evaluate such modifications and verify that they will not compromise the normal and safe use of the wheelchair.

Any modification of the original parameters and set up could seriously compromise the safe operation of the wheelchair causing damage to both the user and the wheelchair itself.

After every adjustment made to the wheelchair, check carefully that all parts are correctly fixed. Check that all screws and nuts are tightened and that all moving parts are functioning correctly.

After any adjustment, always test the wheelchair before giving the product to user and/or his/her attendant.

RehaTEAM® disclaims any responsibility for damage to the product or the people due to any modification that is not properly performed or that, in any case, does not guarantee safety to the user.



SERVICE MANUAL

# TEKNA TILT

## Adult and Junior

Page	adjustment
04	SEAT HEIGHT
05	ANTI-TIPPER
06	BRAKE
07	INVERSION OF BRAKE ASSEMBLY
08	REAR WHEELS REPLACEMENT 1 from 12" (300mm) to 26" (400mm) and vice-versa
09	REAR WHEELS REPLACEMENT 2 from 22" to 24" and vice-versa
10	REAR WHEELS REPLACEMENT 3 from 12" or 16" (300 or 400 mm) to 12" or 16" and vice-versa
11	REAR WHEELS WITH DRUM BRAKE 12", 16", 22" and 24"
14	REAR WHEEL PLATE POSITION
15	DIRECTIONALITY
16	FOOTPLATE DISTANCE
17	DOUBLE FOOTPLATE
18	ONE PIECE FLIP-UP ALUMINUM FOOTPLATE
20	ELEVATING LEG REST
21	BACKREST HEIGHT AND ANGLE
22	BACKREST ANGLE
23	SEAT DEPTH
24	STANDARD REMOVABLE ARMREST
25	SEAT WIDTH ENLARGEMENT
26	QUICK RELEASE AXLE (rear wheel)
27	FOOTPLATE FRAME LOCKING POSITION (only for Exelle Vario)



# SEAT HEIGHT

## SERVICE MANUAL

It is possible to change the seat height by means of the holes that are present on the front forks and on the rear wheel plates.

You can change the seat height only by varying the height **A** between the lower frame and the ground.

The height **B** between the lower frame and the seat base (when flat) is invariable.

The front and rear adjustment must be the same in order to keep the lower frame parallel to the ground.

It is not possible to adjust the fork angle.

Adjust the anti-tipper, see adjustment sheet "anti-tipper"

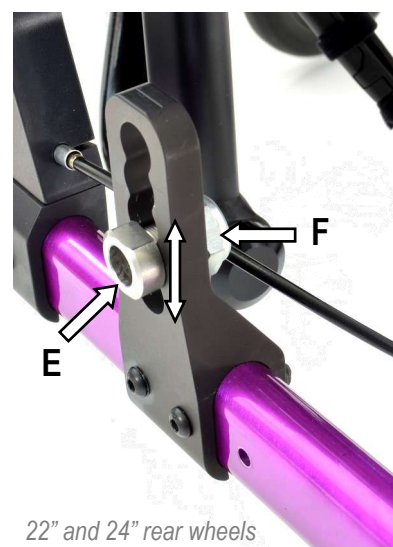
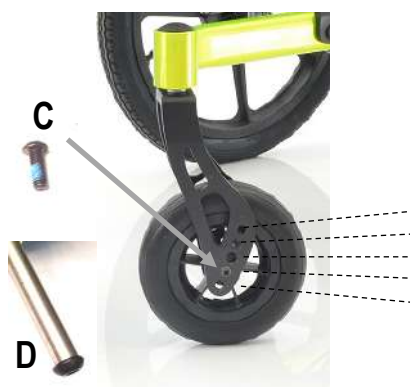
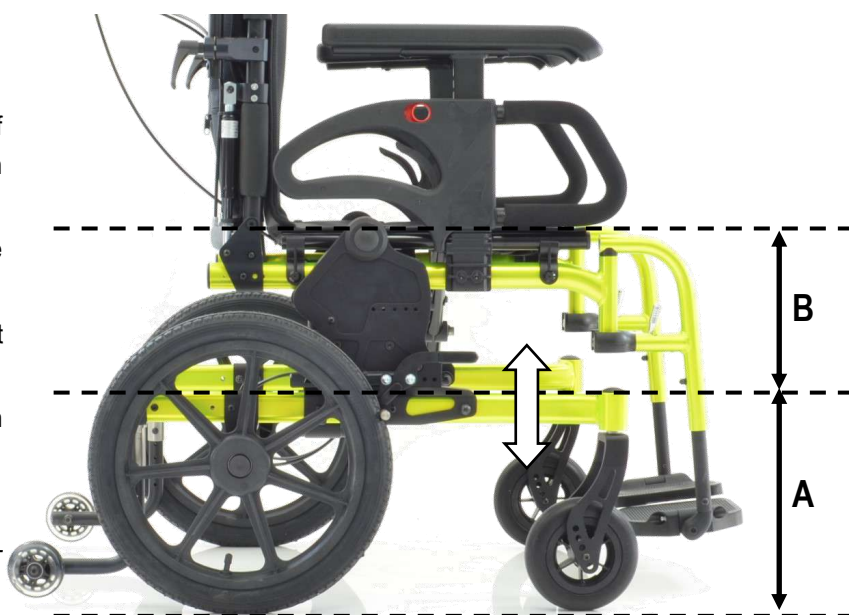

### Front height

Screw off one bolt **C** while holding the other.

Remove the axle **D**.

Position the caster to another hole, insert the axle and fix the bolt **C** holding the one on the other side. It is advisable to spread a drop of mild lock thread glue on the bolts **C**.

### Rear height.

Remove the rear wheel. Screw off the nut **E** from the receiver **F**.

Remove the receiver and position it in another hole of the wheel plate.

Pay attention to all possible washers/spacers (you can check the other side) and fix the nut **E** on the receiver **F**.

If the receiver is fixed to the hole closer to the frame, the nut cannot turn, therefore, screw the receiver, but still hold the nut.

Note: if the nut **E** is not a lock nut, spread some mild lock thread glue on it.

### Adjustment interval

The adjustment interval of the forks and of the rear wheel plate is the same.

Therefore, when you move the casters by one or more holes, the rear wheel move should be of the same extent.

### Rear wheel plate orientation

For 12" and 16" wheels, the plate is facing downward. For 22" and 24" wheels, the plate is facing upward.

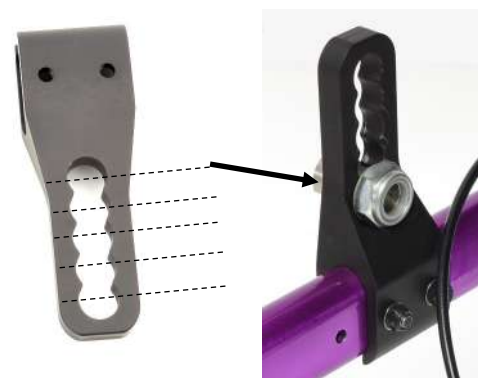



# ANTI-TIPPER

## SERVICE MANUAL

When you change the seat height, it is necessary to check the efficiency of the anti-tip system and possibly re-adapt it to the new height.

The anti-tip wheel should be at least 1 cm, but not over 4 cm from the ground.

Always try the efficiency of the anti-tip system before using the wheelchair.



**To lower** the anti-tipper, screw off the bolt/washer/nut **A** and fix the tube one position lower.

The original assembly do not allow to lower the the tube more than one position (1.5 cm).

The fixing hole is usually the second starting from top.

If one position lower is not enough to make the system efficient, you need to replace the tube with a longer one.

**To raise** the anti-tipper, screw off the bolt/washer/nut **A** and remove the tube.

Cut off 15 mm per position .

Insert the tube into the steel support and fix it with the bolt/washer/nut **A**





# BRAKE

## SERVICE MANUAL

After each adjustment of the rear wheel, it is necessary to adjust the brakes.

### Brake assembly

The brake is fixed to the tilt-in-space body **A** that has two sets of threaded holes **B** and **C**.

The holes **B** are designed to fix the brakes when the size of the rear wheels is 22" or 24".

The holes **C** are designed to fix the brakes when the size of the rear wheels is 12" or 16".

### Adjustment

You have to adjust the brake when the wheels are properly inflated (except solid tyre).

Loosen the two bolts **D** just enough to move the brake forward or backward.

If one or both bolts are not accessible, remove the wheel, loosen the bolts and then put the wheel back on.

Position the knurled rod **P** at a distance **X** of a few millimetres.

Should the slots of the brake tube do not allow for such adjustment, it is necessary to remove one or both bolts **D** and fix the brake tube more ahead or more behind accordingly.

Try the brake fixed, even temporarily, with two bolts, otherwise it will rotate and make the adjustment impossible.

The set of holes, in combination with the slots, always allows for a good adjustment of the brake.

Temporarily fix one of the two bolt **D** and try the brake.

If necessary, repeat the same operations until you reach the good adjustment.

A good adjustment has the brake not too hard to engage but braking, so you will have to find the suitable compromise.

Thus, you have to find a good compromise.

Once you reach the good adjustment, tighten both bolts **D**.

The two bolts **D** may be further or closer to each other.

Note: with 12" wheels, the brake is assembled reversed, with its tube facing frontward.

The adjustment is the same.

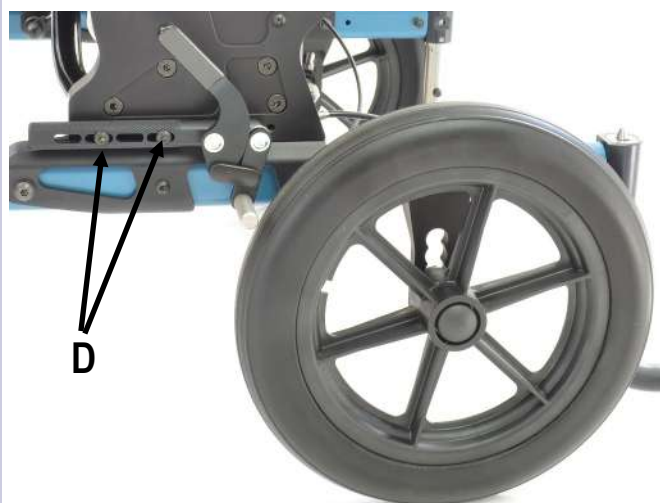
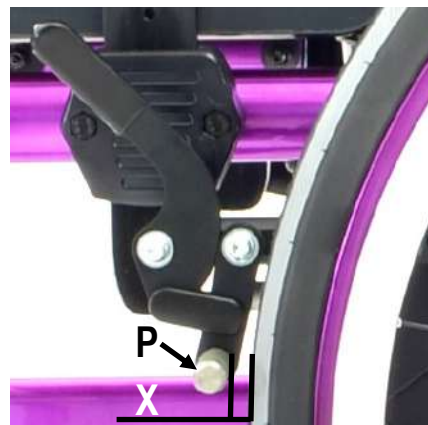
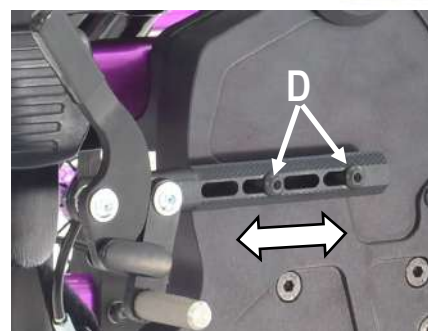
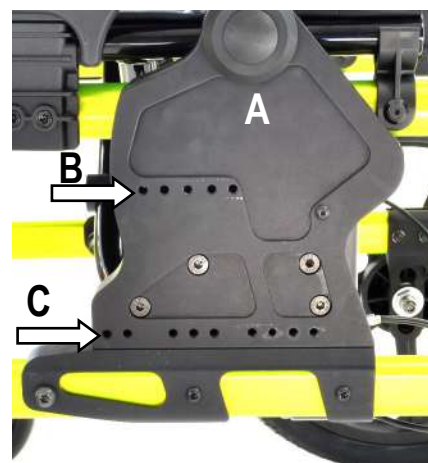

Brake assembly with 12" wheels

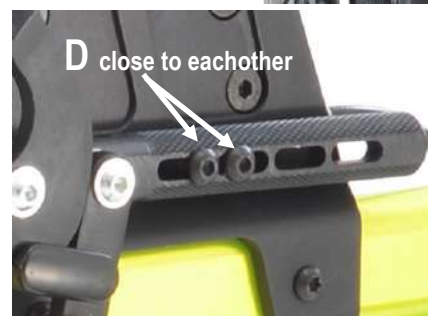
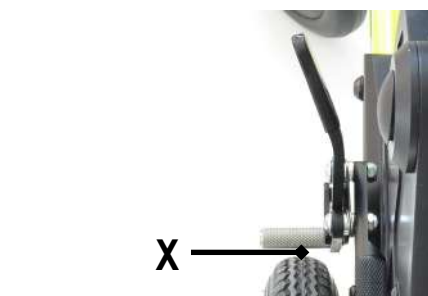



# INVERSION OF BRAKE ASSEMBLY

## SERVICE MANUAL

The inversion of the brake assembly is necessary when you change the rear wheels from 16", 22" or 24" to 12" (or vice-versa). Let's see how to reverse the brake assembly starting from the regular assembly.

You simply have to assemble the brake rod **C** orientate opposite.

Screw off the two nuts **A**.

Screw off the two bolts **B** and detach the brake unit from the brake rod **C** trying to keep all parts together, the spring **D** will tend to move them apart until detachment.

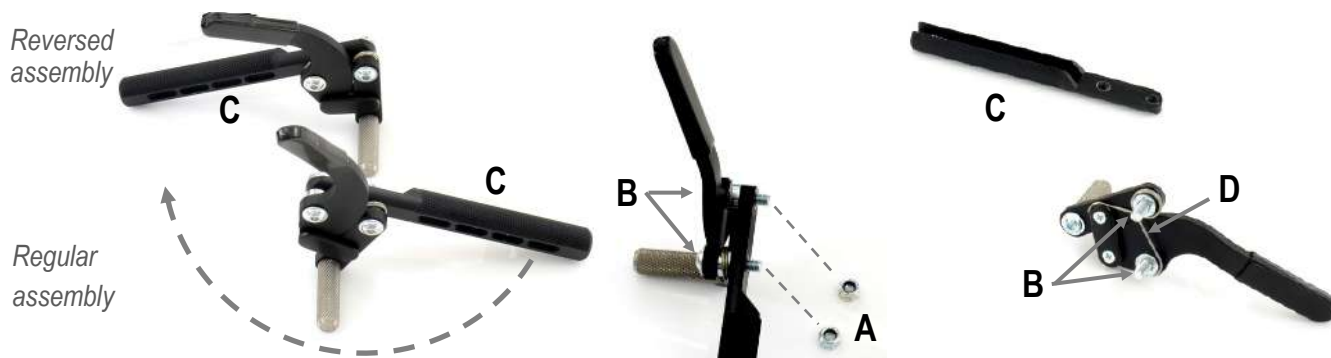

If the spring **D** comes off, lean the parts of the brake unit to each other as shown in the picture here below on the left. The spring has two extremities: a short one **X** and a little longer one **Y**; the extremity **X** has to be under the extremity **Y**. Insert the ring of the spring over the buckle **E1** and with its extremity **X** leant over the curve of the plate **F**.

Then, lean the extremity **Y** over the buckle **E2**.



It may happen that all parts of the brake come off. In such case, start with inserting the buckle **E1** and **E2** (they are the same) and the two bolts **B** (they are the same, too).

Then, lean the parts of the brake unit to each other as shown in the picture above on the left and proceed as above mentioned.

Now, mount the brake rod **C** facing opposite (with respect to the original assembly). Make sure you assemble the brake unit on the correct side of the brake rod, external as shown in the pictures.

Fit the two bolts **B** paying attention to the position of the spring.

The extremity **Y** of the spring may drop between the brake unit and the buckle **E2** (as in the picture below), or the ring may drop between the buckle **E1** and the brake rod, or again, the extremity **X** may detach from the plate **F**.

If one or more of such case occur, re-set the assembly as shown in picture **REF** without removing the bolts **B**.

Screw up the two bolts **B** to full run.

Insert the two nuts **A** and tighten them while holding the bolts **B**.

Check that the brake movement given by the spring works; if it is too frictioned, slightly loosen one or both bolts **B**.

In these pictures, the brake is left. For the right side, the procedure is the same, just mind the symmetry. To reverse the assembly starting from the reversed assembly, proceed likewise.





# REAR WHEELS REPLACEMENT 1

From 12" (300 mm) to 16" (400 mm) and vice-versa

## SERVICE MANUAL

The wheels are provided with a specific assembly kit that includes two receivers with Ø12mm hole, Ø12mm quick release axles, washers, spacers, and nuts.

Therefore, when you change the wheels, you also have to change the receivers that are already assembled on the wheelchair.

In the pictures here below, you should notice that the brake assembly is different. In fact, with 12" wheels, the brake rod is facing forward (reversed assembly), whereas, with 16" wheels, the brake rod is facing backward (regular assembly).

You will have to change the brake assembly, too.

The rear wheel plate, for both sizes of these rear wheels, is assembled facing downward and so it remains.



Remove the wheel.

Screw off the receiver **B**.

See also adjustment sheet "seat height".

Mount the receiver of the new wheel and add washer and spacers until the distance **C** (from the plate to the receiver's head) is, for the time being, 8-10 mm. Temporarily fix the receiver.

Screw off the two bolts **A** and remove the brake.

Put the wheel on.

Now, it is necessary to modify the brake assembly because, as above mentioned, for the 12" and 16" the assembly is different.

To modify the brake assembly, see adjustment sheet "*inversion of brake assembly*".

After reversing the brake assembly, mount it on the wheelchair following the instructions on the adjustment sheet "*brake*".

Now, check that the centre of the tyre is approximately centred with the brake knurled rod. That to guarantee a good braking. Furthermore, with 16" wheels, check that there is no interference between the tyre and the brake rod or the bolts **A** fixing it. All that depends on the distance **C**. If necessary, add or remove spacers accordingly.

Finally, tighten the receiver **B**. If the nut is not a lock nut, spread some mild lock thread glue.

Mind the seat height, see also adjustment sheet "seat height".

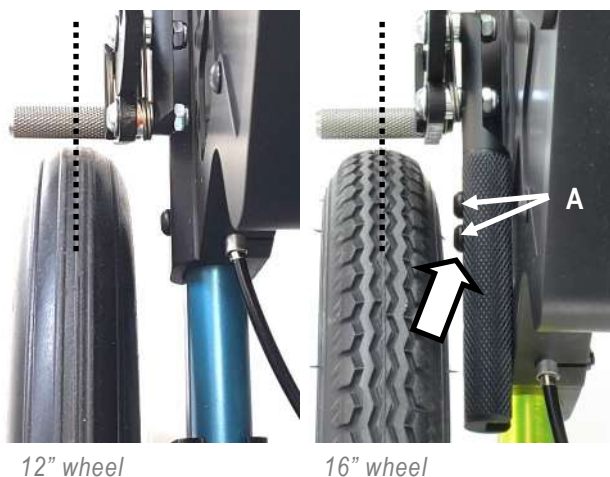





## REAR WHEELS REPLACEMENT 2

From 22" to 24" and vice-versa

### SERVICE MANUAL

The 22" and 24" rear wheels use the same receiver with 1/2" (12.7 mm) hole and the same 1/2" quick release axles.

The rear wheel plate, for both sizes of these rear wheels, is assembled facing upward and so it remains.

Replacing the rear wheel is, thus, quite simple, but pay attention to the seat height, see also adjustment sheet "seat height".

Adjust the brakes, see adjustment sheet "brake".

If you change from 22" to 24" wheel, you need to remove the brake first.

Note: between the head of the receiver and the plate there is no spacers.

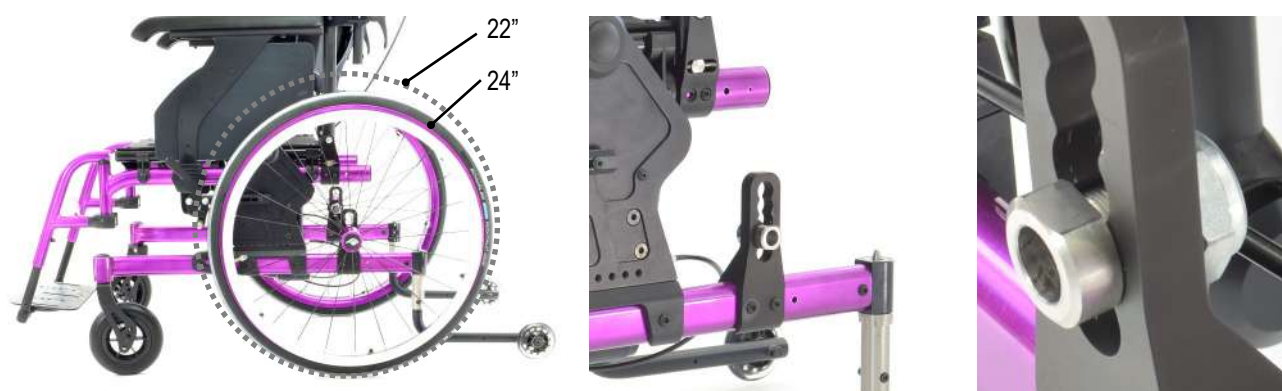



## REAR WHEELS REPLACEMENT 3

From 12" or 16" (300 or 400 mm) to 22" or 24" and vice-versa

### SERVICE MANUAL

The replacement of the rear wheels from 12" or 16" (small rear wheels) to 22" or 24" (big rear wheels) and vice-versa implies the inversion of the rear wheel plates assembly.

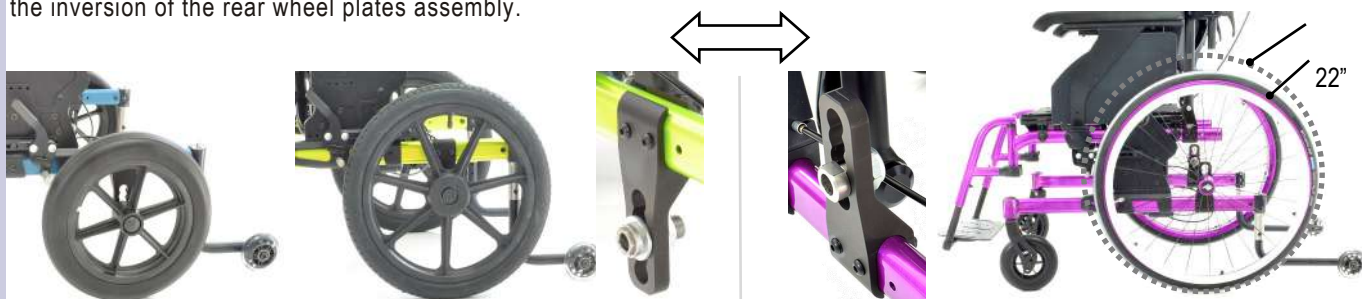

This example refers to a replacement from small to big rear wheel. In the opposite case, follow the same instructions likewise.

Remove the rear wheel and the brake, too, see adjustment sheet "brake".

You will probably need to screw off and screw in the bolts **A** and **C** even though they pass through non threaded holes. Do not hammer them in or out if they do not pass through, but just screw them off or in.

Screw off the bolt/washer/nut **A B** and hammer off (with a mallet), without exaggerating, the anti-tip unit.

Screw off the two bolts/washers/nuts **C D** and slide off the wheel plate.

Now, insert the wheel plate facing upward making sure its side **E** is facing externally to the wheelchair.

Insert the two bolts/washers/nuts **C D** and fix the wheel plate.



Mount the wheel receiver following the instructions of the adjustment sheets "seat height", "rear wheel replacement 1" and "rear wheel replacement 2".

Mount and adjust the brake following the instructions of the adjustment sheet "brake".

In case the wheelchair is equipped with tie-down rings, the instructions remains the same.

The tie-down ring has always to be mounted opposite to the part of the wheel plate with the height adjustment holes and with its bending facing externally.

In the pictures aside, with small rear wheels, the wheel plate is facing downward and the ring upward, whereas, with big rear wheels, the assembly is opposite.



Small rear wheels



Big rear wheels



# REAR WHEELS WITH DRUM BRAKE

12", 16", 22" and 24"

## SERVICE MANUAL

The adjustment of the wheels with drum brake and the possible replacement can similarly be performed as described for the wheel without drum brake. The parking brake is present, too.

In this sheet, thus, only the assembly of the drum brake unit and the assembly and adjustment operation lever and cable are shown. For all the rest, consult the adjustment sheets: "seat height", "brake", "rear wheel replacement 1", "rear wheel replacement 2" and "rear wheel replacement 3" and proceed likewise.

**The plate of the drum brake unit** is flat for the 12" and 16" wheels, whereas it is shaped for the 22" and 24" wheels.

The wheel receivers change, too.



12" wheel

**Flat plate**, receiver with high head, spacers **A**, washer, nut and short quick release axle.



16" wheel

**Flat plate**, receiver with short head, spacers **A**, washer, nut and short quick release axle.



22" and 24" wheel

**Shaped plate**, long receiver with high head, spacers **A**, washer, nut and long quick release axle.

### Drum brake unit assembly

The assembly should be such as to prevent the rotation of the plate of the drum brake unit when using the brake.

To prevent such rotation, a plate **B** is fixed to the rear wheel plate and to the plate of the drum brake unit.

To align the fixing of the plate **B**, with flat plate (12 and 16" wheels) there should be a 7 mm spacer **C** between the plate **B** and the rear wheel plate, whereas, with the shaped plate (22" and 24" wheels) there should be two 2 mm washers **D**.

The plate **B** is fixed to the drum brake unit plate with the bolt/nut **E** in both cases. The bolt **F** (with its corresponding washer/nut) fixes the other side of the plate **B** passing through the wheel plate and the frame.

Between the drum brake unit and the wheel plate there should always be two 6 mm spacers **A**.

Wheel plate facing down

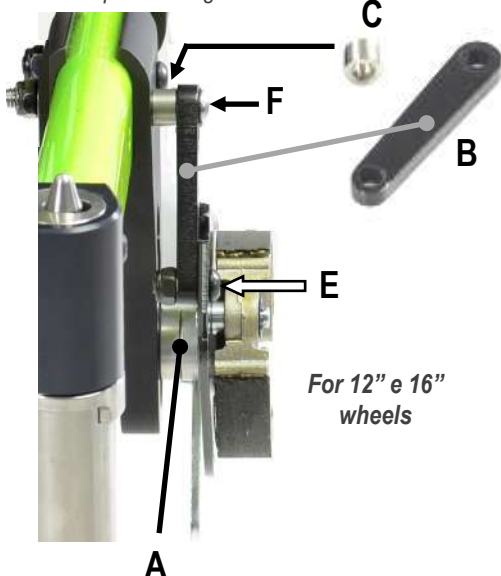

For 12" e 16" wheels

Wheel plate facing up

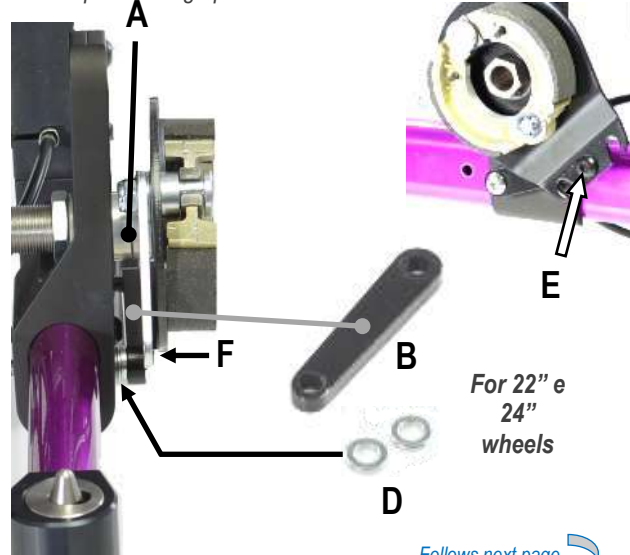

For 22" e 24" wheels

Follows next page



# REAR WHEELS WITH DRUM BRAKE

12", 16", 22" and 24"

## SERVICE MANUAL

### 12" and 16" wheel: assembly for each position on the wheel plate

For each of the 5 height adjustment holes (1, 2, 3, 4, 5) of the wheel plate, it is shown the correct assembly.

In particular, pay attention to the fixing of the plate **B** on the wheel plate.

For the holes 1, 2 and 3, the fixing of the plate **B** with the bolt **F** is through the front hole of the wheel plate.  
For the holes 4 and 5, the fixing of the plate **B** with the bolt **F** is through the rear hole of the wheel plate.

To match the fixing point of the plate to the central hole of the drum brake plate when assembling the parts, just turn the two components until the holes are aligned.

Then insert and fix the bolt/nut **E** and tighten. Tighten the bolt **F** and its corresponding nut, too.

The jaws lever **G** should be facing the rear side of the wheelchair.

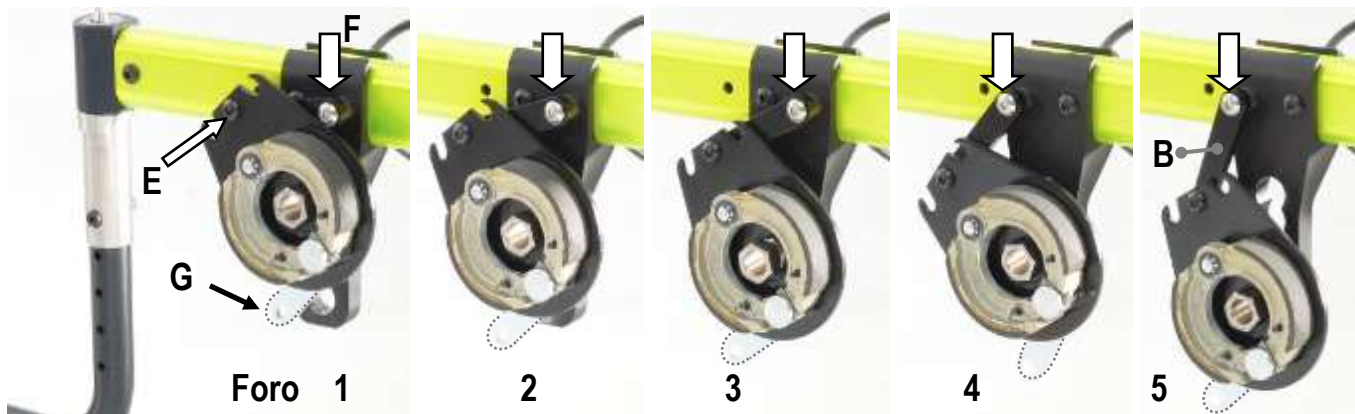
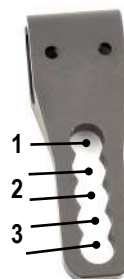

If the jaws lever **G** is facing opposite, just turn it to the correct position.

You will notice the spreading apart of the jaws whose maximum extent is when the lever is in central position.

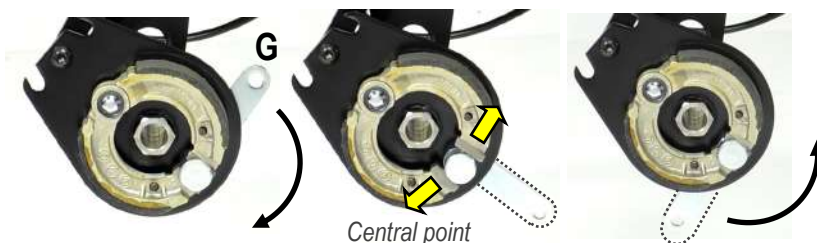

### 22" and 24" wheel: assembly for each position on the wheel plate

Follow the instruction above.

Here after, the combinations.

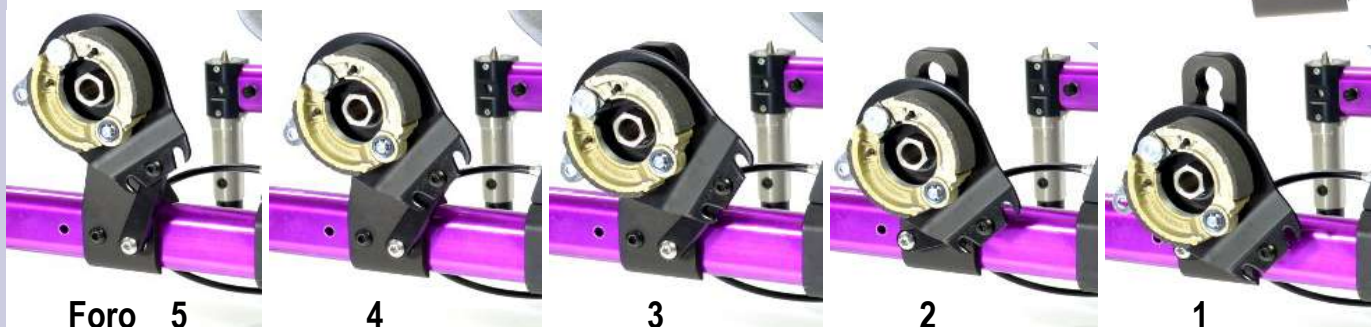

Follows next page



# REAR WHEELS WITH DRUM BRAKE

12", 16", 22" and 24"

## SERVICE MANUAL

### Assembly of the operation cable of the drum brake

1. Let the steel cable through the lower hole of the brake lever.
2. Insert the sheath and the adjustment barrel and nut that have an opening.
3. Once you have inserted the adjuster barrel, turn the nut in order to prevent the cable from coming off.
4. Insert the adjustment bolt into the brake lever. It is important to keep this position at the end of the adjustment.

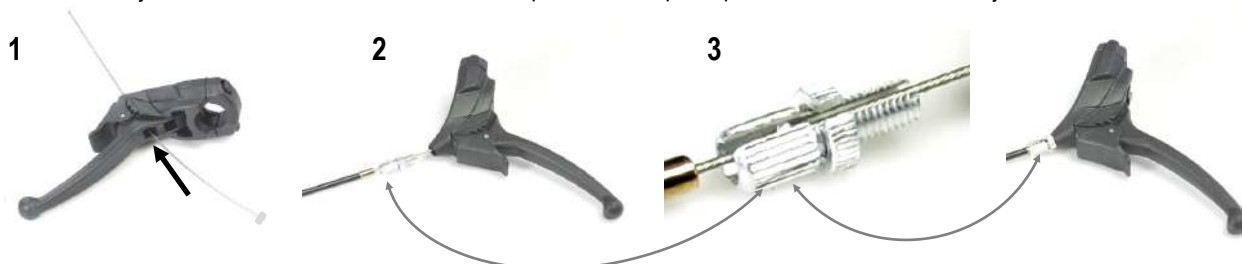

5. Insert the cable clamp bolt on the jaws lever as indicated, but without tightening.
6. Insert the adjuster support on the plate fork. That support should be free to rotate.
7. Screw the adjuster all the way down making sure the nut is present.
8. Now, let the cable through the hole of the cable clamp bolt. If the path is not free, try to mount the adjuster support on the other fork.
9. Mount the brake lever on the handlebar. The cable should not find interference nor squeezings on the way from the drum brake unit to the lever. Remove the two screws to separate the parts and fix the lever on the handlebar.



Make sure the adjuster barrel is within the brake lever, see point 4.

Pull the cable until you feel a little pressure.

Tighten the nut fixing the cable clamp bolt.

Try to operate the brake without the wheel and then with the wheel on. Make a check.

If the cable is not tight enough, you can tighten it by unscrewing the adjuster on the brake unit and/or the adjuster nut on the brake lever.

If it is too tightened, you may not insert the wheel or it brakes without pulling the lever. In that case, loosen the cable clamp bolt and start from point 10 again.

Once you reached the good adjustment, tighten the the nut of the adjuster on the brake unit in order to lock its position.

Note: in these pictures, the assembly refers to 22" or 24" wheels, the wheel plate is facing up.

For 12" and 16" wheels, follow the same instructions.



## REAR WHEEL PLATE POSITION

### SERVICE MANUAL

You can horizontally move the rear wheel plate by one position (2.5 cm), being it orientated upward (12" and 16" wheels) or downward (22" and 24" wheels).

In fact, the frame has three pre-drilled holes, through two of which the rear wheel plate is fixed with the bolts **A** and corresponding washers/nuts **B**.

Screw off the two bolts/washers/nuts **A B** and move the plate to the other position aligning the holes.

You will probably need to screw off and screw in the bolts **A** even though they pass through non threaded holes. Do not hammer them in or out if they do not pass through, but just screw them off or in!

Insert the two bolts/washers/nuts **A B** and fix the plate.



In case the wheelchair is equipped with tie-down rings, the instructions remains the same.

The tie-down ring has always to be mounted opposite to the part of the wheel plate with the height adjustment holes and with its bending facing externally.

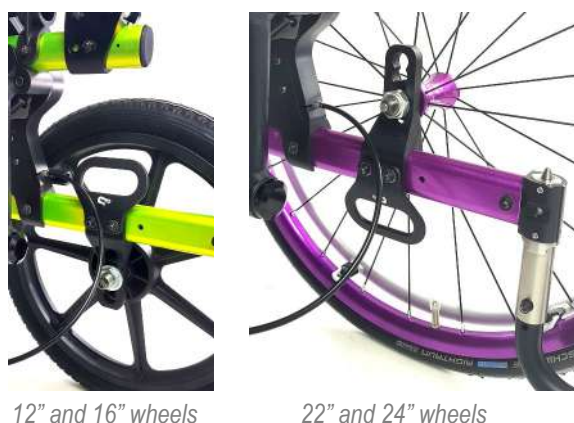



# DIRECTIONALITY

## SERVICE MANUAL

A very important aspect of any wheelchair is its directionality.

To check if the wheelchair goes straight, sit on it, push it and let it go until it stops.

If something is wrong, the slower the wheelchairs moves forward (momentum close to nothing), the more likely it turns right or left. Therefore, if no or irrelevant turn occurs, the wheelchair is properly adjusted.

Cause	Reason	Solution
SURFACE	The surface where the test is being performed is not even and flat	Test the chair on even and flat surface
REAR WHEELS	The rear wheel are not equally inflated	Inflate both tyres at the same pressure
	The tyres of the two rear wheel are different or differently	Change the tyres
	The rear wheels are not adjusted at the same height	Adjust the rear wheel height
	The camber of right and left wheels are different or differently adjusted	Adjust the camber.
	The wheel, when turning, touches the side guard or the brakes	Fix or replace the side guard. Add spacer on the receiver. Adjust the brake.
	The wheels doe not turn smoothly	Clean or change the bearings
FRONT WHEELS	The casters are not adjusted at the same height	Adjust the front wheels at the same height
	The tyres of the two front wheels are different or differently	Change the wheels
	The fixing bolts of the fork/fork support/clamp are loosened	Check and tighten all fixing bolts
	The caster does not turn smoothly	Clean the bearings.
FOOTPLATE	The footplate tubes are adjusted at different height.	Adjust the tubes at the same height



SERVICE MANUAL

## FOOTPLATE DISTANCE

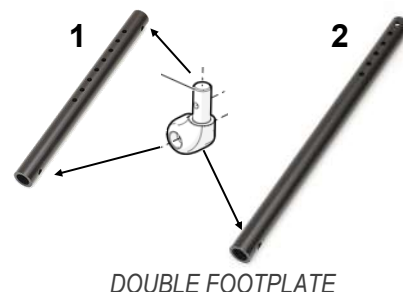

### HEIGHT ADJUSTMENT EVERY 1.5cm

Remove the bolts **A** and their corresponding nuts and washers **B**.

Slide the footplate tube up or down until the necessary height.

Insert the bolts through the nearest holes and tighten.

Where present, it is possible to use the second hole **C**, too.

If necessary, you can adjust the height of the two independent footplates differently.

With one piece footplate, the two tube have, of course, to be adjusted at the same height.

The footplate tube can be either short (1) or long (2).

The short tube has two positionings for the adjustment support (RH and LH) in order to reach short footplate distances.

The long tube has only one positioning for the adjustment support and it is design for longer footplate distances.

The tubes for double footplates and one piece footplates are the same, but the adjustment support is different.

To reach the shortest footplate distance, one can, both at original assembly or afterwards, cut off both the footplate tube and the part of the frame just below the welding as shown by the dotted line **D** on the pictures at the top of the page.

It should be clear that the possible adjustment is then limited.

The adjustment support is fixed to the tube with the bolt **E** on which a drop of strong lock thread glue is spread. Should you need to change the position of the support (only short tube), in order to unscrew the bolt, you may need to heat it first. When you assemble the support, spread a drop of strong lock thread glue on it.

After adjustment, check that between the lower side of the footplate and the ground there is at least 2 cm and that there is no interference between footplate and casters.

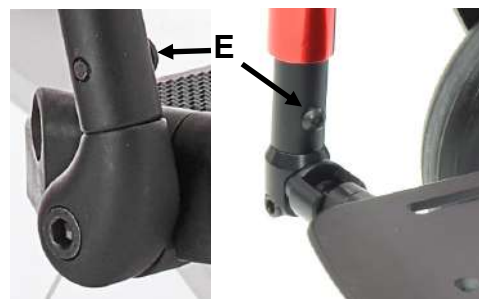

### Nota per il telaio abdotta

The fixing hole for the adjustment support, with respect of the height adjustment holes, is not rotated by 90°, but by 76°.

That is to compensate the angle of the front frame abduction.

The tube is only short and it allows for two positions for the adjustment support.

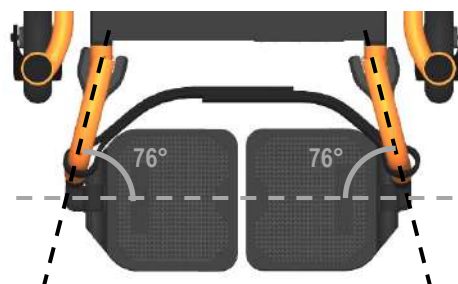





## DOUBLE FOOTPLATE



### ANGLE ADJUSTMENT

Loosen the bolt **A**.

Turn the plate clock or anti clock wise.

Once you find the correct inclination, tighten the bolt.

If necessary, you can adjust the inclination of the two independent footplates differently.

### POSITIONING

2 positions: 2/3 internal or 2/3 external.

To reverse the position, remove the footplates complete with tubes and assemble right side to left and the other way round—see also chapter “height adjustment”. It may be necessary to adjust the angle.



### FRICIONING THE ROTATION

To adjust the friction of the footplate rotation movement, tighten or loosen the bolt **B** (the corresponding nut is held within it housing). Usually, when the footplate is lifted up the adjustment holds it in place.



### Particularity

Should you need a plate positioned 2/3 internal and the other 2/3 external, it is necessary to have two adjustment supports of the same side (two right or two left).

*Note: for right hand side we intend right facing back, thus, if assembled on the left, it will be left facing front;*

*for left hand side we intend left facing back, thus, if assembled on the right, it will be right facing front;*

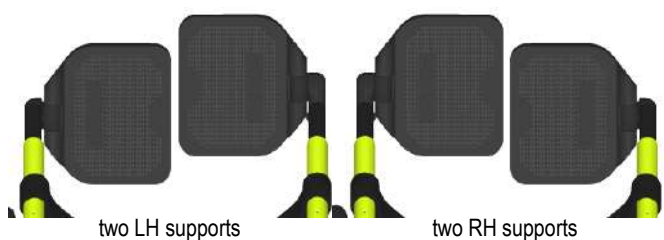



# ONE PIECE FLIP-UP ALUMINIUM FOOTPLATE

SERVICE MANUAL

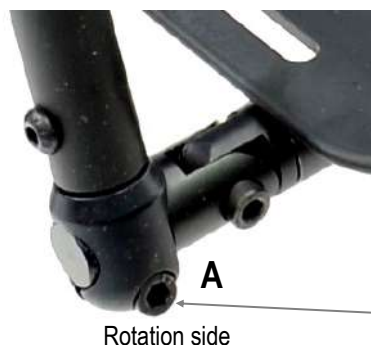

Rotation side



Lock side



A

## ANGLE ADJUSTMENT

Leave the footplate engaged in the using position.

Loosen the bolt **A** of both adjustment supports.

Turn the plate forward or backward.

Once reached the correct inclination, tighten the bolt **A** on the lock side.

Check the footplate engages and disengages easily (you may need to make a minor angle adjustment working on the plate) and then tighten the bolt **A** of the rotation side.

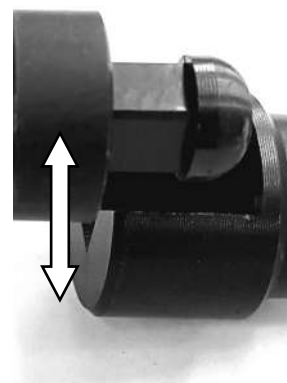

## POSITIONING

4 positions: internal; 2/3 internal; 2/3 externa; external

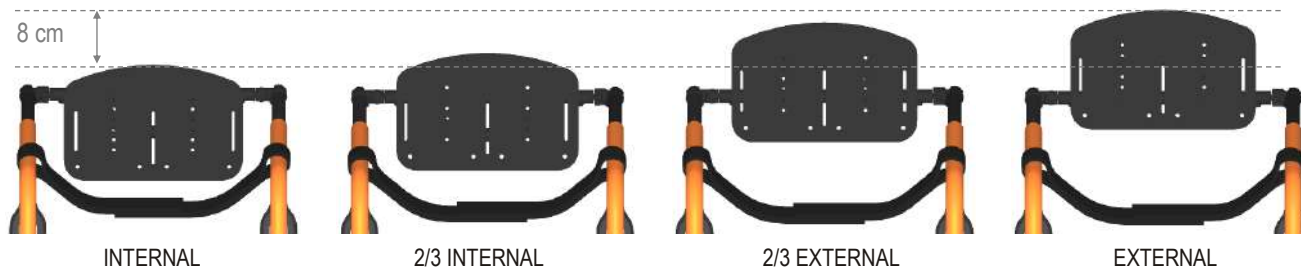

## CHANGING THE PLATE POSITION

Remove the 4 bolts **B** and fix the plate using the other set of holes.

The possible positions are three, every 1.5 cm, both with the footplate tubular internal and external.

The plate is always orientated with its curves side facing front (however, you can reverse it, too.).



Footplate tubular internal



Footplate tubular external

Follows next page



SERVICE MANUAL

# ONE PIECE FLIP-UP ALUMINIUM FOOTPLATE

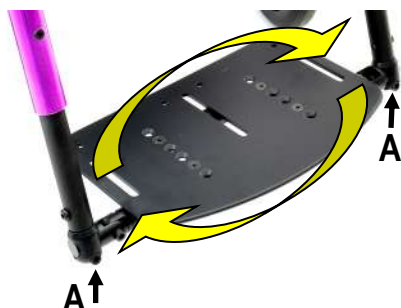

## REVERSING THE FOOTPLATE

- 1) Loosen the angle adjustment bolts **A** and slide off the lock and rotation sides supports from the tube and assemble them reversing their position.
- 2) Or, remove the tubes, follow instructions of chapter *footplate distance* and assemble them reversing their side.

Finally, adjust the inclination and tighten the bolts **A**— see also “*angle adjustment*”.

Using either of these two methods, you can turn the footplate position from internal to external (or vice versa) or from 2/3 internal to 2/3 external (or vice versa).

When reversing the footplate in either these two methods, you change the lock side, too.

## CHANGING THE LOCK SIDE WHILE KEEPING THE SAME PLATE POSITION

Loosen the bolt **A** of the rotation side and remove the footplate.

The footplate tubular is fixed to the rotation support and to the lock support with two bolts **C** each side.

Screw off the four bolts **C**. If they result hard to unscrew, heat them with a hot air blower to make the lock thread glue lose its efficiency.

Slide off the support of the lock side. If it is hard to remove, insert it into the lock support (that is still fixed to the footplate tube) and pull it off while turning it clockwise and anti-clockwise alternatively.

Loosen the bolt **A** of the lock side, remove the support and mount it, without fixing it, to the other side of the wheelchair.

Slide off the support of the rotation side. If it is hard to remove, insert it into the free adjustment support (where the lock support was earlier mounted), fix it with the bolt **A** and pull it off while turning it clockwise and anti-clockwise alternatively.

Spread some mild or strong lock thread glue on the bolts **C**.

Insert the lock and rotation supports on the footplate tubular opposite and fix them with the bolts **C**.

Pay attention when fixing the rotation support, in fact, it can rotate on one direction only (if it is mounted opposite, the footplate can only rotate downward).

Adjust the inclination and tighten the bolts **A**— see also “*angle adjustment*”.

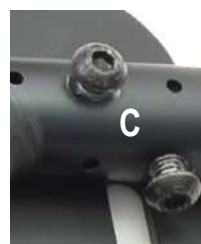

## FRICTIONING THE ROTATION

To adjust the friction of the footplate rotation movement, tighten or loosen the bolt **D**.

It is advisable to remove the bolt, squeeze a little part of its thread with a long nose pliers, spread a drop of strong thread lock glue, insert it and screw it. In fact, the movement of the footplate can lead that bolt to unscrew itself. Usually, when the footplate is lifted up the adjustment holds it in place.

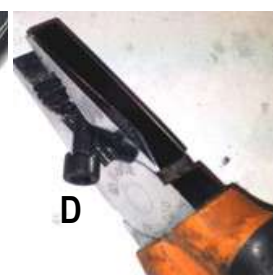



SERVICE MANUAL

## ELEVATING LEG REST

### HEIGHT ADJUSTMENT

The leg rest is easily adjustable in height also by the user or his/her attendant. In fact, just swing out the lever **A**, slide the tube up or down and swing the lever to lock the clamp.

If the lever does not tighten the tube enough, screw the bolt **B** half of a turn, close the lever **A** and check if the tube is firm. If necessary, repeat the same operations until you reach the good adjustment without the lever being too hard to swing in and out.

The leg rest external tube **C** allow for short footplate distance, too.

In fact, if it is not cut at origin according to the requested footplate distance, you can cut it off by 10 cm.

The holes **D1** and **D2** are the positioning and fixing points of the clamp with the lever **A** by means of the grab screw **E**.

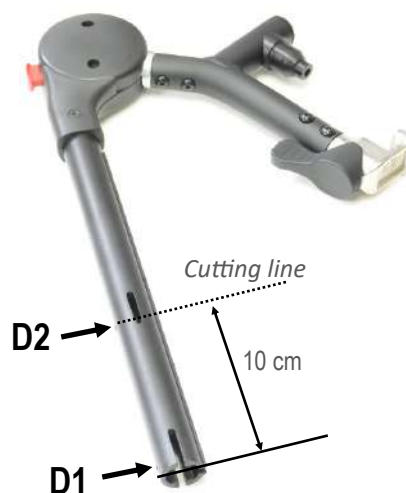
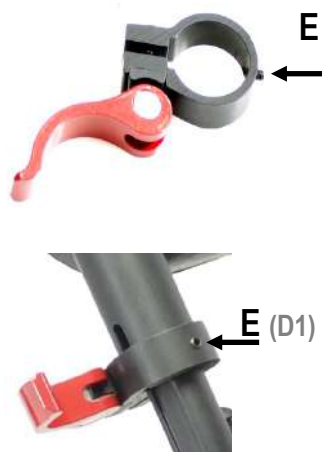
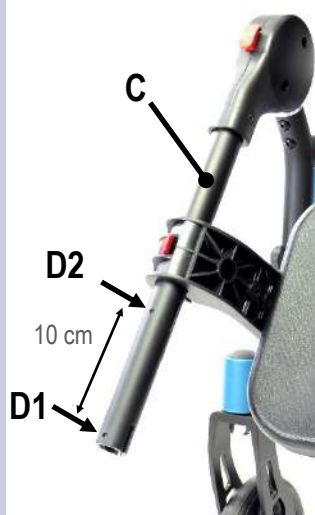
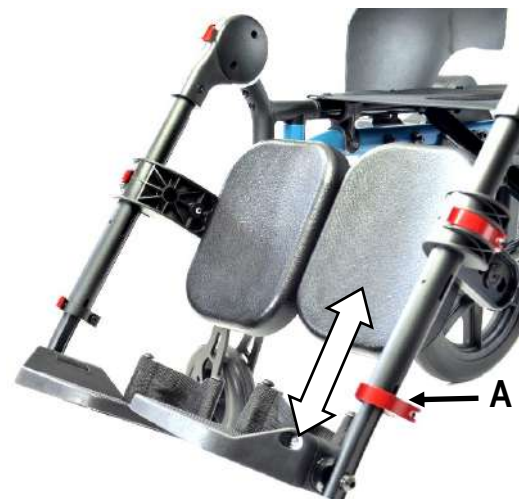

Remove the calf support (swing the lever out and slide the support off) to make cutting operations easier.

Cut off the tube 10 cm along the indicated line that lays 6 mm below the centre of the hole **D2** and that cut off the round part of the slots (two laterals and one on the rear side of the tube).

Position and fix the clamp with the grab screw **E**.

If you tighten this grab screw, the footplate tube may be hard to get into the tube. In such case, just loosen the grab screw the minimum needed.

Insert the footplate and, if footplate tube is too long, cut it off accordingly.



Cutting line

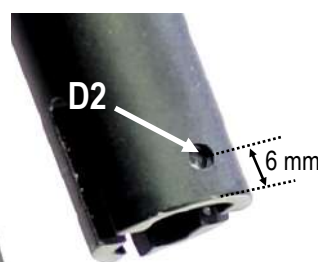

Cut tube



Possible cut

### ANGLE ADJUSTMENT

Loosen the bolt **F**, tilt the plate and tighten the bolt.

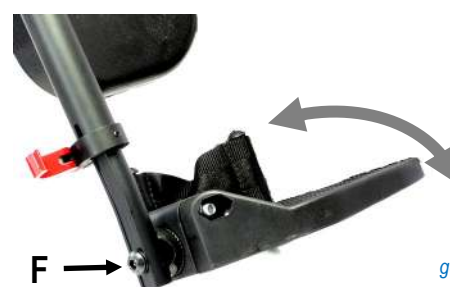



# BACKREST HEIGHT

## SERVICE MANUAL

### With fix or reclining aluminium tube

Screw off the bolt/washer/nut **A**.

The inner tube can slide into the outer tube for 8 cm until the point **B** where the outer tube's thickness changes from 2 to 3 mm.

With the same inner tube, you can fix it maximum 4.5 cm higher, whereas, if you need to lower it, you may need to cut off the exceeding part.

Once you find the good adjustment, fix the tube with the bolt/washer/nut **A**.

### With folding titanium tube

The inner diameter of the tube is constant and it allows the inner tube to slide all the way down the outer tube.

Screw off the bolt/washer/nut **A**.

The bolt **C** that fixes the support of the handlebar tube can fix the inner tube, too. In that case, but also in the case that bolt impeded the inner tube from sliding down, remove the bolt **C**.

Slide the inner tube up or down to the necessary height.

Insert the bolt **C** (if you removed it), the bolt/washer/nut **A** and fix the tube.

Pay attention when fitting the bolt **C** into the threaded hole of the support.

Should you irredeemably damage the thread of such hole, you can repress it with a 5 mm drill pin and fix the support with a longer bolt, washer and nut.

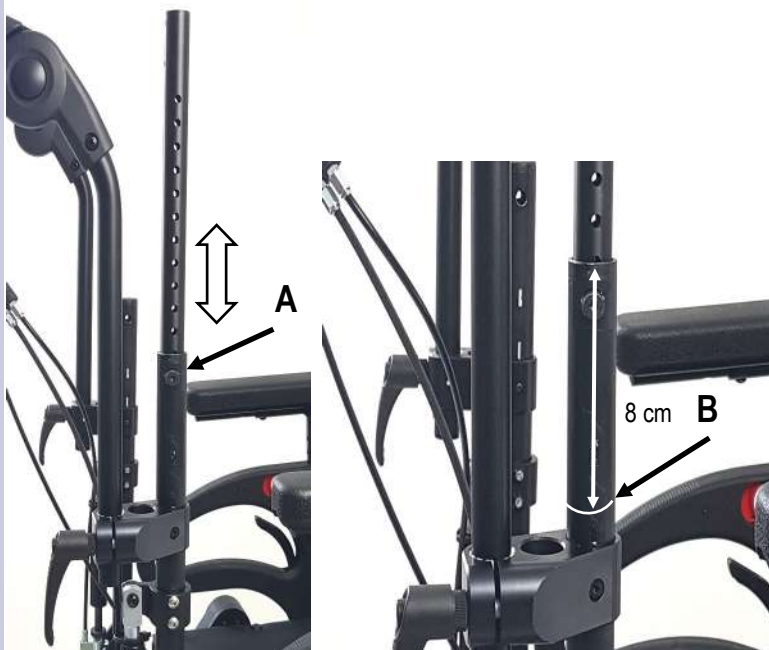

FIX OR RECLINING ALUMINIUM TUBE



FOLDING TITANIUM TUBE



Threaded hole



SERVICE MANUAL

## BACKREST ANGLE

### With fixed backrest

Loosen the nut **A**.

Screw or unscrew the adjustment grab screw **B** to open or close the backrest angle.

Watch how the angle changes while you are turning the grab screw.

If the grab screw **B** is too hard to turn, loosen the bolt **C**.

If it is still too hard, you can "help" it by pushing the backrest tube to the wished direction while you are turning the grab screw **B**.

If it keeps on being too hard, remove nut/washer **A** and push off the head of the adjustment axle **D** until the grab screw **B** is off the support; then, tilt the backrest tube to the wished inclination, adjust the grab screw **B** accordingly and insert the adjustment axle into the support. The axle **D** could be hard to slide within the support, you can help yourself, gently, with a mallet.

Finally, tighten the nut **A**.

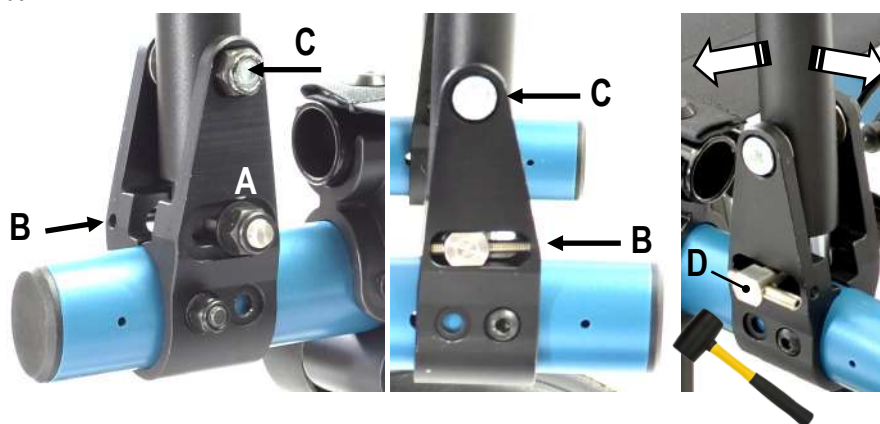

### With folding backrest

Loosen the nut **A**.

Screw or unscrew the adjustment grab screw **B** to open or close the backrest angle.

Watch how the angle changes while you are turning the grab screw.

If the grab screw **B** is too hard to turn, unlock the backrest and try again.

If it is still too hard, remove nut/washer **A** and push off the head of the adjustment axle **D** until you can get access to the grab screw **B**; this way, there is no pressure on the grab screw **B**. Then adjust it and insert it into the support.

After adjustment, tighten the nut **A** step by step trying to lock and unlock the backrest a few times.

If the hook **E** does not go down completely, slightly loosen the nut **A**.

If it does not go down completely yet, slightly loosen the bolt **C**.

You must not loosen the nut **A** too much; otherwise, the lock axle **D** becomes instable.

Check and, if necessary, clean and/or lubricate all parts subjected to friction.

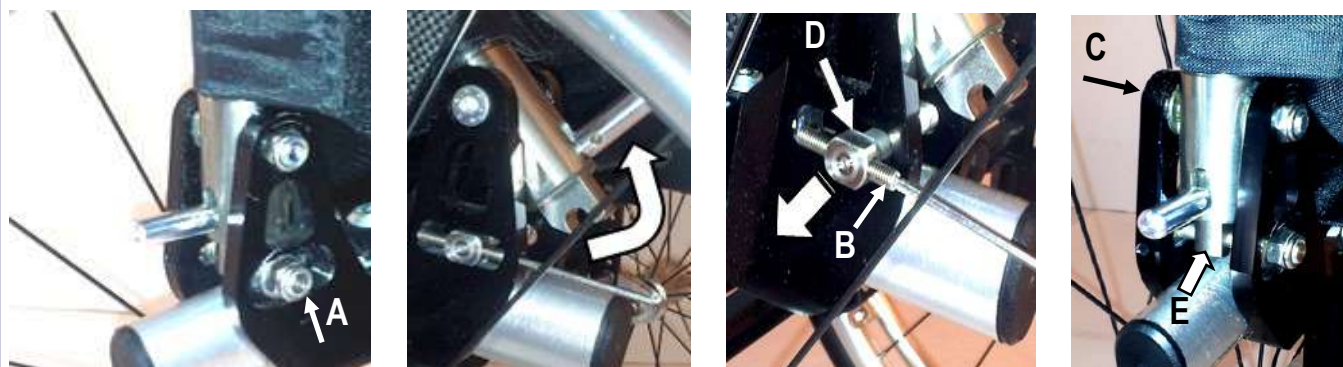

### Attenzione

DO NOT OVER TIGHTEN the nut **A**, you may damage the housing for the lock axle **D**.

The adjustment of the two backrest tubes has to be the same otherwise, the push handlebar and/or the possible backrest postural system may not engage and lock correctly.



# SEAT DEPTH

## SERVICE MANUAL

### Fix or folding backrest

The frame, in its rear side, has three pre-drilled holes (1, 2, 3) for the backrest support positioning. These holes are 25 mm from each other, whereas, the interval of holes **X Y** on the backrest support is 15 mm. You can perform the adjustment even combining these two possibilities.

Loosen the bolt **A** and the nut **B**.

Screw off the bolt/washer/nut **C**.

Slide the backrest support along the frame and position it aligning one of its holes to one of the frame's.

Insert and tighten the bolt/washer/nut **C**.

If the bolt is hard to insert through the holes even if screwing it, check the holes alignment.

Tighten the nut **B** and the bolt **A**.

DO NOT OVER TIGHTEN the nut **A**, you may damage the housing for the lock axle **D**.

Repeat the same operation on the other side of the wheelchair.

The position of the two backrest supports has to be the same.

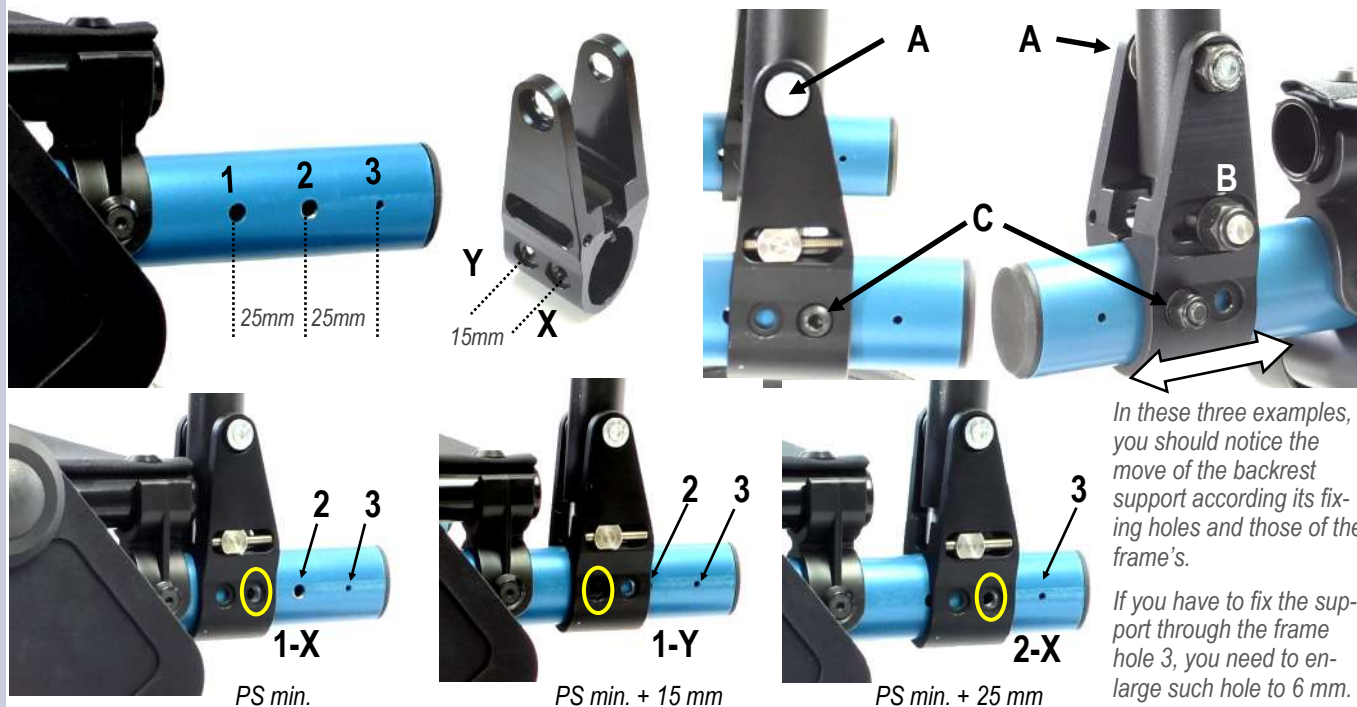

### Reclining backrest

You can carry out the adjustment in the same way, but, in order to slide the backrest support, you have to loosen the bolt/nut **A** and the bolts/washers/nuts **E** and **F** (the nut **B** is not present).

Once you reach the wished position of the support, insert and tighten the bolt/washer/nut **C**, tighten the bolt **A** and the bolts/washers/nuts **E** and **F**.

### Advise

To make operations easier, it is advisable to detach one side the push handlebar.





# STANDARD REMOVABLE ARMREST

SERVICE MANUAL

## HEIGHT ADJUSTMENT

The blade **A** has, in its vertical part, a series of holes where to screw the bolt **C**. This bolt engages into the hollow **D** of the support **B**. Therefore, to change the height, just remove the bolt **C** and screw it in another hole.

If you need to lower the armrest, the side guard could touch the support **B** and the upper side of the tilting body **E** and thus impede the adjustment. In such case, it is necessary to cut the lower side of the side guard following the same drawing.

Remove the two bolts **F** and draw the cutting line.

Saw the side guard along the line and round off the edge with a scissor's blade or with fine sand paper.

Assemble the side guard. The holes for the bolts **F** remain the same.

**WARNING:** do not tighten the bolt **C** and **F** excessively: it may damage the threaded hole until making it unusable.

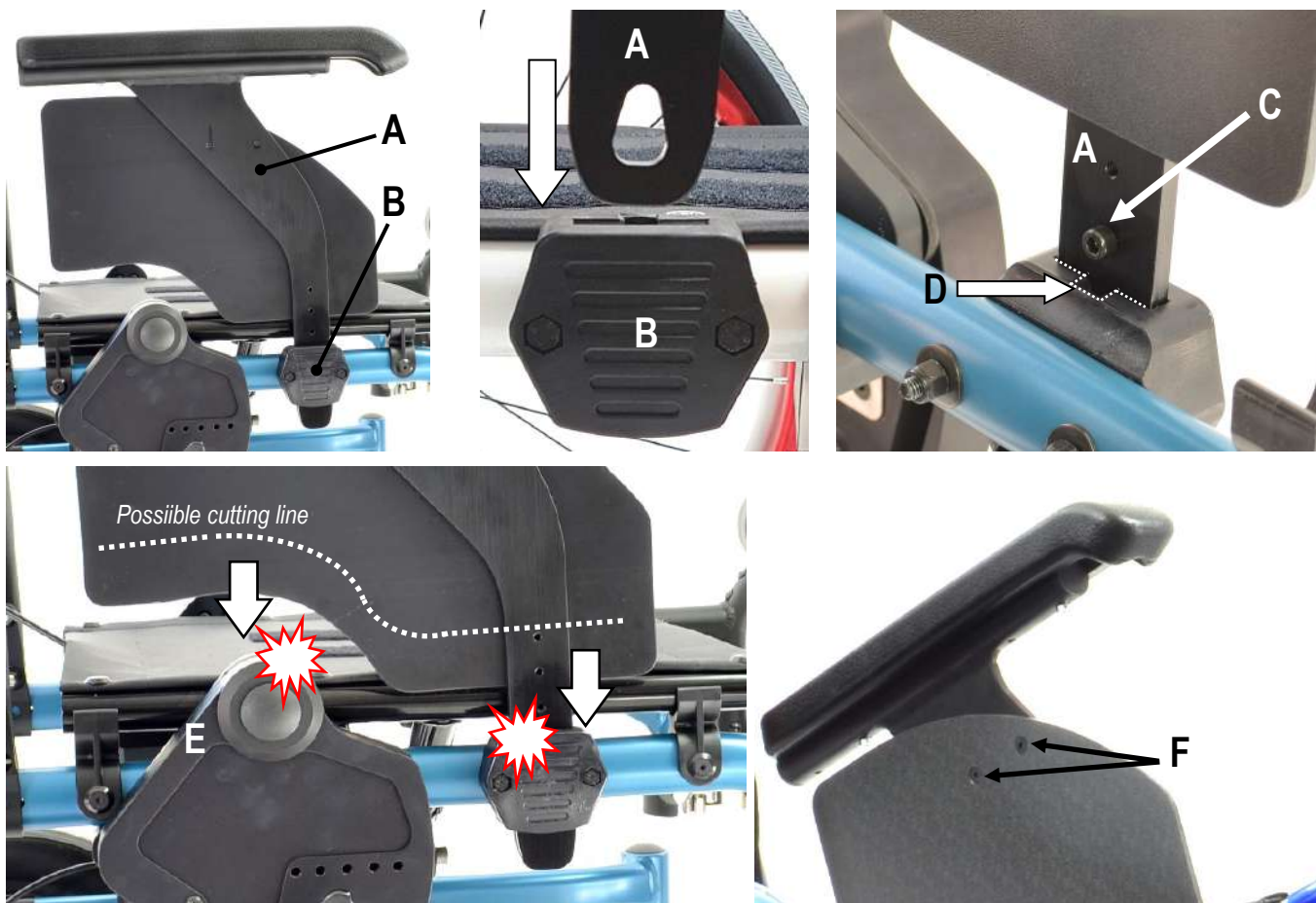





# SEAT WIDTH ENLARGEMENT

## SERVICE MANUAL

The seat width enlargement is possible by means of proper spacers to be put between the armrest's support **A** and the frame.

### Standard removable armrest.

Screw off the two bolts/washers **C**.

You do not need to hold the bolts **B** because their head is embedded within the support **A**.

Remove the support **A** and the spacers **D**, too.

Position the spacer **E** on the support **A**, insert the longer spacers **D** and longer bolts **B**.

Pay attention to the alignment of the spacers **D**.

You can mount these spacers through the frame ever before mounting the support.

Finally, tighten the bolts/nuts **C**.

The seat width enlargement is 15 mm for each support (total 30 mm).

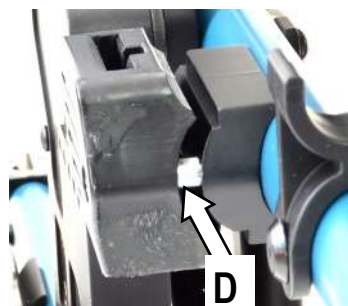
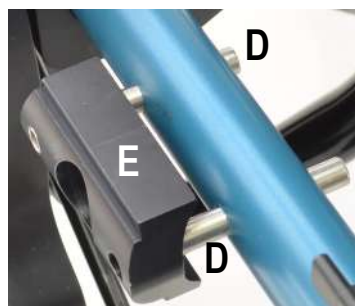
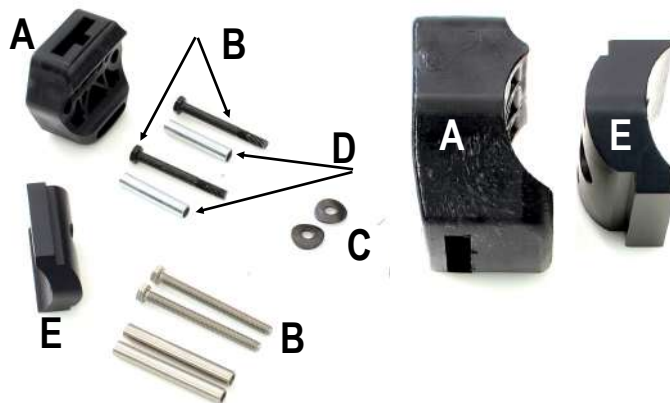
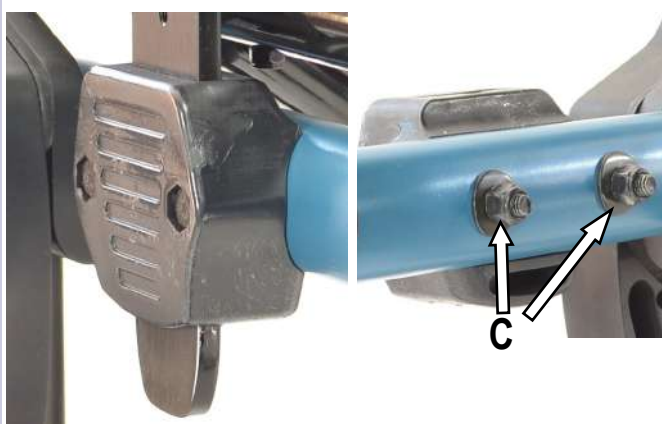

### Progeo 2020 removable armrest

You can perform the enlargement following the same instructions above, but there are some differences: to screw off the nuts/washer **C** you need to hold the bolts **B**; the thin spacer **E** is present with the standard assembly, while the thick spacer **F** is that which is used to enlarge the seat.

The seat width enlargement is 10 mm for each support (total 20 mm).

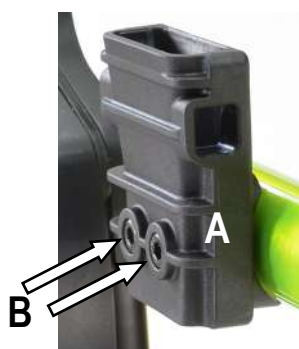



# QUICK RELEASE AXLE

(rear wheel)

SERVICE MANUAL

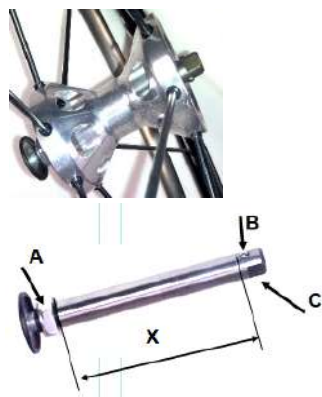

Adjust the quick release axle so that the rear wheel is safely fixed with no risk that it comes off accidentally.

At the same time, there should be no or very little play.

To check if the rear wheel is safely fixed, take hold of the hub without pressing the release button, and try to pull the wheel in and out.

As regular maintenance, it is advisable to clean the quick release axle and spread a little of grease on it.

**If the wheel comes off**, the distance **X** between the nut **A** and the balls **B** is too short, therefore, it is necessary to unscrew the nut **A** while holding the point **C** of the axle. **If there is play**, the distance **X** between the nut **A** and the balls **B** is too long, therefore, it is necessary to screw the nut **A** while holding the point **C** of the axle

In both cases, make a few tries until the correct adjustment. There is no need to remove the axle from the wheel.



It may happen that you adjust the axle so that the wheel only seems properly fixed, but it is not safe.

In fact, to check the adjustment, you have also to try to press the button just a little bit (as guidance,  $\frac{1}{4}$  of its run) and pull the wheel. If it comes off, it means that it may come off while driving! Therefore, this is a very important **safety check**.

If the wheels comes off, unscrew the nut a little bit until you have the proper adjustment.

**If the wheel (the axle) gets stuck** in the receiver, you can proceed in two ways:

- press the quick release button, pull the rear wheel and, at the same time, with a mallet, gently hit (a little harder if necessary) the hub or spokes of the wheel.
- press the quick release button so that the axle's pin is out, then position a spanner on the axle's shaft and around the pin. Now, while pushing the axle's button, pull the rear wheel and gently hit the spanner. To do that, you need the help of another person.

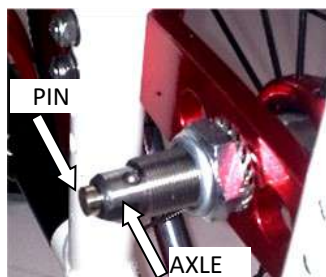

**The reasons why the wheel can get stuck can be two.**

- the receiver is slightly damaged; in this case, with a  $\frac{1}{2}$  reamer, re-pass the receiver's hole.
- when pushing the axle's button, the balls do not fall inside the axle's shaft; first, clean the axle, then try to push the button a few times to see if you have solved the problem; if not, press the button, hold the axle's pin with a wrench and unscrew the button half of a turn. Check and if necessary do the same with another half turn. Do not unscrew the button too much: the pin will come off and, consequently, the balls will fall to the ground.





# FOOTPLATE FRAME LOCKING POSITION

(only for Exelle Vario)

## SERVICE MANUAL

The swing-away and removable "VARIO" frame has the characteristic of locking to a steel ring **A**. Such ring is fixed to the frame by means of three headless bolts: **B1 B2** in front and **B3** at rear. The fixing point **C**, thus, is not one only, but, indeed, it is variable in rotation.

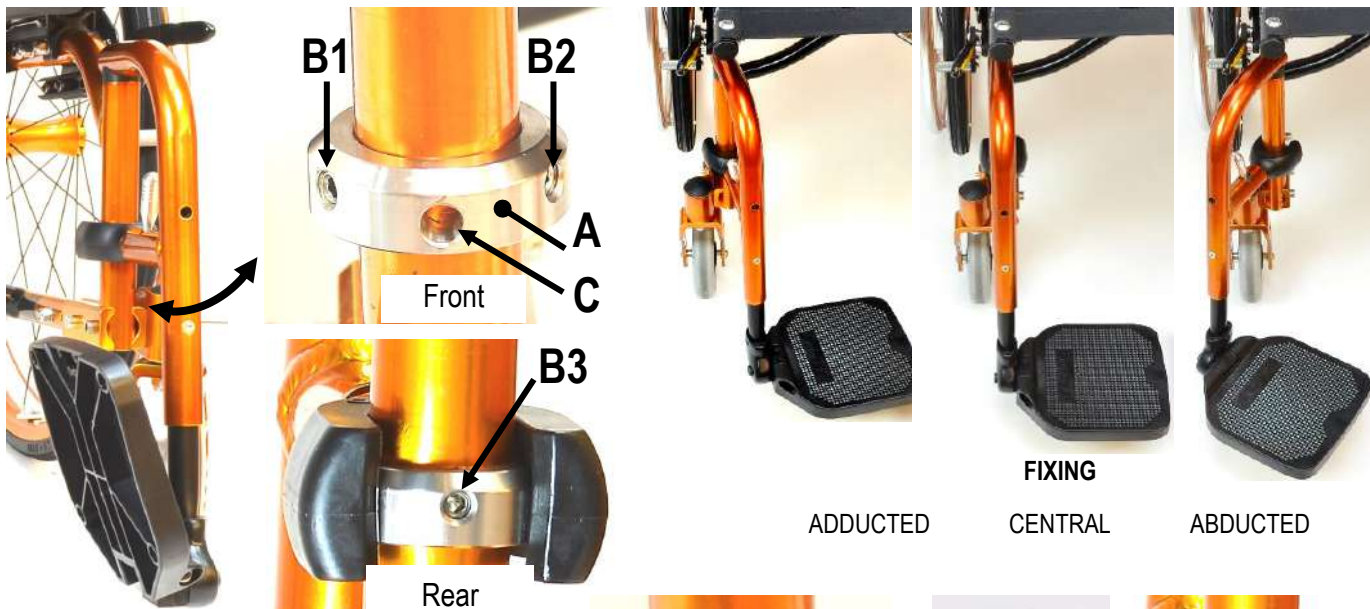

Remove the footplate.

Remove the front headless bolts **B1** and **B2**.

Put the footplate on and lock it.

Loosen the headless bolt **B3**.

Now, turn the footplate until you need it.

Screw and tighten the headless bolt **B3**.

Remove the footplate (or turn it until getting access to one headless bolt **B1** or **B2** first and then the other).

Insert and screw the headless bolts **B1** and **B2** all the way down without tightening them.

Now tighten the two headless bolts.

Put the footplate on and lock it.

At origin, we assemble the wheelchair with central fixing point.

You can change the fixing point at any time as long as the footplate is "double footplate".

The footrest plate is not designed to be turned for compensation.

Note: with the abducted frame, the frame is already rotated by 14° and the footplate tubes have the holes suitable for such rotation. You can, however, carry out the same operation,

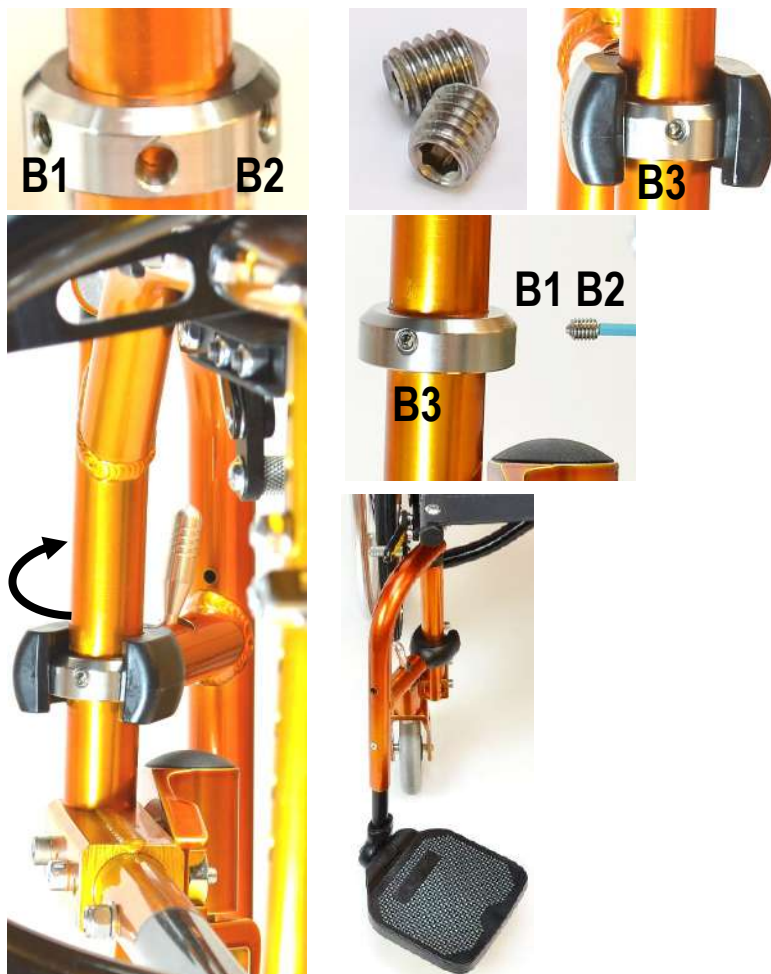

It is advisable to spread a drop of mild lock thread glue on the headless bolts **B**.