



Quickie Q300 M Mini

Instructions for Use

QUICKIE[®]

000691022.EN



We at SUNRISE MEDICAL have been awarded the ISO-13485 certificate, which affirms the quality of our products at every stage, from R & D to production. This product complies with the standards set forth in EU and UK regulations. Options or accessories shown are available at extra cost.



If you have any queries about the use, maintenance or safety of your wheelchair, please contact your local approved Sunrise Medical service agent. If you do not know of an approved dealer in your area or have any other questions please write or telephone:

Sunrise Medical
Thorns Road
Brierley Hill
West Midlands
DY5 2LD
England
Phone: 0845 605 66 88
Fax: 0845 605 66 89
www.SunriseMedical.co.uk

Contents

1.0 User information	4
1.1 This user manual	4
1.2 For further information	4
1.3 Symbols used in this manual.....	5
2.0 Safety	6
2.1 Symbols and labels used on the product.....	6
2.2 Safety: Temperature	6
2.3 Safety: Moving parts, (Fig.2.10).....	7
2.4 Safety: Electromagnetic radiation.....	7
2.5 Safety: Choking hazard.....	8
2.6 Safety: Using a (vehicle mounted) wheelchair lift.....	8
2.7 Safety: Trays.....	8
2.8 Safety: Lifting the wheelchair	8
2.8 Instructions for use with Remote Key Fob Stop Switch fitted	9
3.0 Intended use of the wheelchair.....	10
3.1 Area of application: The user.....	10
3.2 Area of application: The user environment.....	11
4.0 Setting up the wheelchair	12
4.1 Seating system.....	12
4.2 Seat height	12
4.3 Centre of gravity.....	12
4.4 Controller height and depth	12
4.5 Control system programme	12
4.6 Lap strap / seating positioning belt	13
5.0 Using the wheelchair	14
5.1 Checking wheelchair before use.....	14
5.2 Making a transfer	15
5.3 Driving the wheelchair	15
5.4 Curves.....	16
5.5 Braking & Emergency stop.....	16
5.6 Driving on a slope.....	17
5.7 Obstacles & kerbs:.....	18
5.8 Pushing the wheelchair.....	18
5.9 (Powered) seating options	20
5.10 Different Backrest Configurations.....	21
6.0 Batteries, charging and range	22
6.1 Batteries	22
6.2 Charging batteries:	23
6.3 The range of your vehicle:.....	24
6.4 Battery warranty:	25
6.5 Replacing batteries.....	25
6.6 Disconnecting batteries for air transport.	25
7.0 Transportation	26
7.1 Transport of the wheelchair in a car.....	26
7.2 Using the Dahl Docking System	28
7.3 The wheelchair as a passenger seat	31
7.4 Special transport requirements.....	32
7.5 Hoisting the wheelchair:	33
7.6 General transport warnings.....	33
8.0 Maintenance & cleaning	34
8.1 Maintenance	34
8.2 Tyre maintenance and pressures.....	35
8.2.1 Tyre pressure	35
8.2.2 Tyre wear	35
8.2.3 Drive wheel tyre repair.....	36
8.3 Wheels & tyres maintenance.....	38
8.4 Lighting maintenance:.....	39
8.5 Cleaning and disinfection.....	39
8.6 Medium to long term storage:	39
9.0 Disposal.....	40
10.0 Trouble shooting	41
11.0 Technical specifications: Applicable norms / standards	41
12.0 Warranty	49
13.0 Nameplate	50

Dealer signature and stamp

1.0 User information

Thank you for choosing a Sunrise Medical wheelchair. Sunrise Medical's high-quality mobility products are designed to enhance independence and make your everyday life easier.

As a part of our ongoing product improvement initiative, Sunrise Medical reserves the right to change specifications and design without notice.

However, any changes to information provided for existing users shall be clearly communicated if they are safety critical.

Further, not all features and options offered are compatible with all configurations of the wheelchair.

All dimensions are approximate and may be subject to change.



The intended lifetime of the wheelchair is 5 years. Please DO NOT use or fit any 3rd party components to the wheelchair unless they are officially approved by Sunrise Medical.

1.1 This user manual

This user manual will help you to use and maintain your wheelchair safely. This entire user manual for this wheelchair consists of three booklets:

- The general wheelchair user manual (this booklet)
- The user manual for the seating system
- The user manual for the controller

When necessary this general user manual refers to other manuals as shown in the table below:

 Seating system:	Refers to the user manual for the seating system.
 Controller:	Refers to the user manual for the controller.
 Battery charger:	Refers to the user manual for the battery charger.

Do not use your wheelchair until this entire manual and all relevant booklets have been read and understood!

If one of the user manuals was not included with your wheelchair, please contact your dealer immediately.

1.2 For further information

Please contact your local, authorized Sunrise Medical dealer if you have any questions regarding the use, maintenance or safety of your wheelchair. In case there is no authorized dealer in your area or you have any questions, contact Sunrise Medical either in writing or by telephone.

For information about product safety notices and product recalls, go to www.SunriseMedical.co.uk

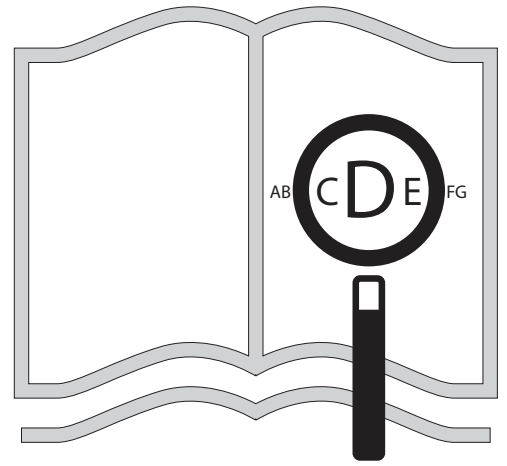

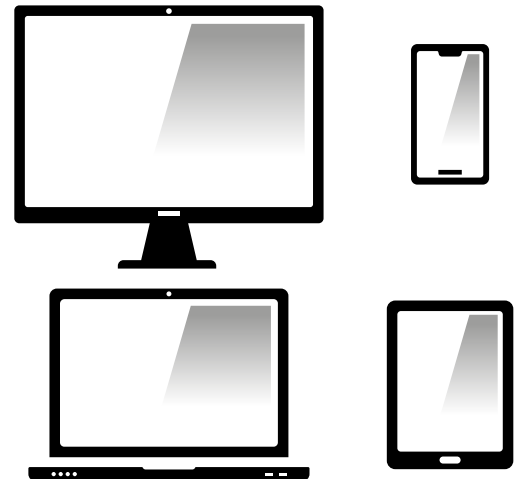

If you are visually impaired, this document can be viewed in PDF format at www.SunriseMedical.co.uk



or alternatively is available on request in large text.



1.3 Symbols used in this manual

 DANGER!	Potential risk of injury or serious injury or death
 WARNING!	Potential risk of injury
 CAUTION!	Potential damage to equipment

 As the manufacturer, SUNRISE MEDICAL, declares that this product conforms to the Medical Device Regulation (2017/745).

 As the manufacturer, SUNRISE MEDICAL, declares that the product conforms to the UK Medical Devices Regulation 2002 No. 618.

NOTE:

General user advice.

Not following these instructions may result in physical injury, damage to the product or damage to the environment!

Notice to the user and/or patient: Any serious incident that has occurred in relation to the device should be reported to the manufacturer and the competent authority of the Member State in which the user and/or patient is established.

B4Me special adaptations

Sunrise Medical strongly recommends that in order to ensure that your B4Me product operates, and performs as intended by the manufacturer; all the user information supplied with your B4Me product is read and understood, before the product is first used.

Sunrise Medical also recommends that the user information is not discarded after reading it, but it is kept safely stored for future reference.

Medical Device Combinations

It may be possible to combine this Medical device with one or more other Medical Device or other product. Information on which combinations are possible can be found at www.Sunrisemedical.co.uk. All combinations listed have been validated to meet the General Safety and Performance Requirements, Annex I Nr. 14.1 of the Medical Device Regulation 2017/745.

Guidance on the combination, such as mounting, can be found at www.SunriseMedical.co.uk.

2.0 Safety

Follow the instructions carefully next to these warning symbols! Not paying careful attention to these instructions could result in physical injury or damage to the wheelchair or the environment. Wherever possible, safety information is provided in the relevant chapter.

2.1 Symbols and labels used on the product

The signs, symbols and instructions affixed to the wheelchair comprise part of the safety facilities. They must never be covered or removed. They must remain present and clearly legible throughout the entire lifespan of the wheelchair. Replace or repair all illegible or damaged signs, symbols and instructions immediately. Please contact your dealer for assistance.

Fig. 2.1. Warning - Do Not Touch - HOT

Fig. 2.2. Taxi fixation point

Fig. 2.3. Warning – Danger of finger entrapment

Fig. 2.4. Warning – Ensure that the seat interface quick release is screwed in tight before using your wheelchair, especially on a slope

Fig. 2.5. Warning – Do not drive your wheelchair on a slope with the backrest reclined and/or the seating in standing mode

Fig. 2.6. Warning – Maximum user weight for the wheelchair: 136 kg

Fig. 2.7. Freewheel mechanism: outward lever down = freewheel

Fig. 2.8. Warning - Do not operate in C-Me mode on slopes

Fig. 2.9. UK Responsible Person label (example only).

Fig. 2.10. The serial number and information label, (example only).

Fig. 2.11. Location of Serial Number Label, (*overleaf* - Fig. 2.11 Mid wheel).

2.2 Safety: Temperature

WARNING!

- Avoid physical contact with the wheelchair's motors at all times. Motors are continuously in motion during use and can reach high temperatures. After use, the motors will cool down slowly. Physical contact could cause burns. Allow the motors after using at least 30 min. to cool down.
- If you do not use the wheelchair, ensure that it is not exposed to direct sunlight for lengthy periods of time. Certain parts of the wheelchair, such as the seat, the back and the armrests can become hot if they have been exposed to full sunlight for too long. This may cause burns or allergic reactions to the skin.



Fig. 2.1



Fig. 2.2

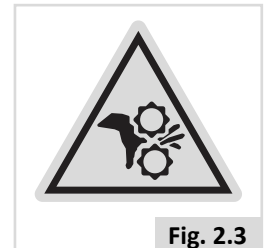

Fig. 2.3



Fig. 2.4



Fig. 2.5



Fig. 2.6

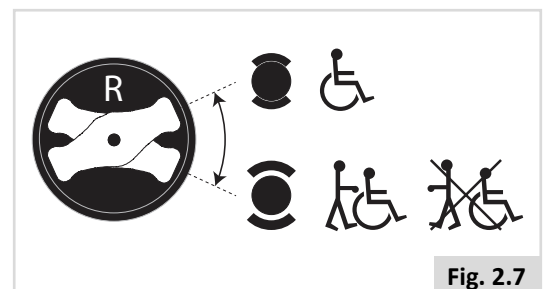

Fig. 2.7



Fig. 2.8

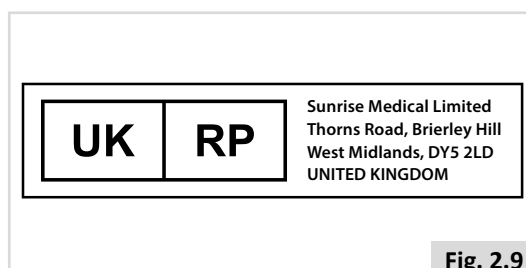

Fig. 2.9

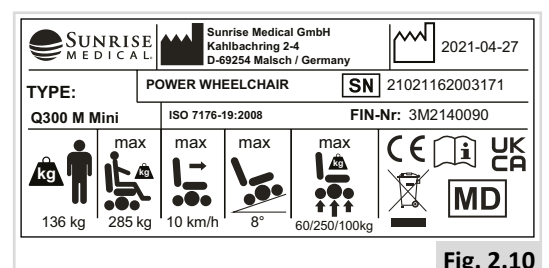

Fig. 2.10

2.3 Safety: Moving parts, (Fig.2.12)

DANGER!

A wheelchair has moving and rotating parts. Contact with moving parts may result in serious physical injury or damage to the wheelchair. Contact with the moving parts of the wheelchair should be avoided.

- Wheels (turning and castor)
- Powered tilt in space adjustment
- Powered seat elevator option
- Powered recline adjustment
- Swing-away bracket of the controller

2.4 Safety: Electromagnetic radiation

CAUTION!

The standard version of your electric wheelchair has been tested on the applicable requirements with respect to electromagnetic radiation (EMC requirements) In spite of these tests:

It cannot be excluded that electromagnetic radiation may have an influence on the wheelchair. For example:

- mobile telephony
- large-scale medical apparatus
- other sources of electromagnetic radiation
- It cannot be excluded that the wheelchair may interfere with electromagnetic fields. For example:

- shop doors
- burglar alarm systems in shops
- garage door openers

In the unlikely event that such problems do occur, we request that you notify your dealer immediately.

DANGER!

- When operating two-way radio, walkie-talkies, C.B., Amateur radio, public mobile radio and other powerful transmitting devices the wheelchair should be brought to a halt and turned off.
- The operation of cordless, mobile telephones and cell phones including hands-free devices is permitted but if abnormal operation of the wheelchair is encountered then the chair must be brought immediately to a halt and turned off.

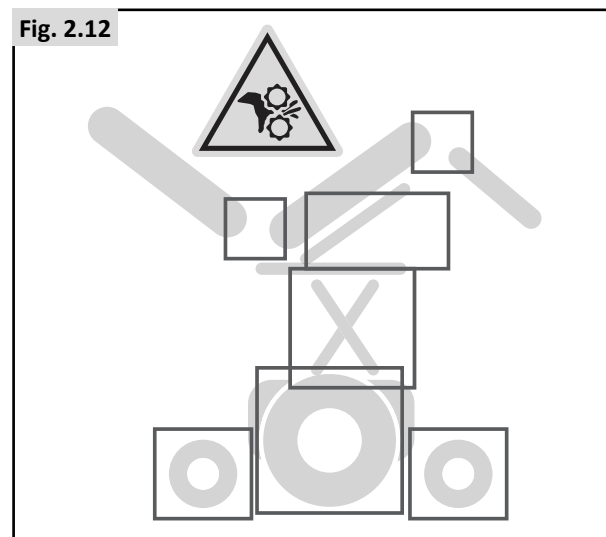
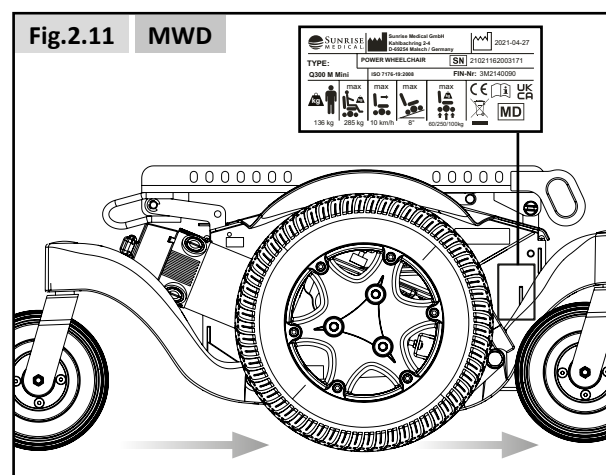

2.5 Safety: Choking hazard



This mobility aid uses small parts which under certain circumstances may present a choking hazard to young children.

2.6 Safety: Using a (vehicle mounted) wheelchair lift

Wheelchair lifts are used in vans, buses and buildings to help you move from one level to another.



- Ensure that the user and all carers fully understand the lift manufacturer's instructions for using the passenger lift.
- Never exceed the lift manufacturer's recommended safe working load and load distribution guidance.
- Always turn off all power when you are on the lift. If you fail to do so, you may touch the joystick by accident and cause your chair to drive off the platform. Be aware that a roll-stop at the end of the platform may not prevent this.
- Always position the user securely in the chair to help avoid falls while on the lift.
- Always ensure the chair is in drive mode when using passenger lift (wheels locked not in freewheel mode).

2.7 Safety: Trays

Safety: Swing away tray:



- The maximum weight allowed for the tray is 2.5kg.
- Do not overload the tray, this could cause the tray to break or could cause the chair to become unstable.
- Do not leave lit cigarettes or other heat sources on the tray as this could cause the tray to deform and mark.
- Ensure that all extremities and clothing are clear when positioning the tray for use.

2.8 Safety: Lifting the wheelchair



- Do not lift this seating system by any parts that are removable, doing so may result in damage to the seating system or injury to the user.

2.8 Instructions for use with Remote Key Fob Stop Switch fitted.

WARNING!

These instructions for use must be read by all responsible adults who come into contact with this Powered wheelchair, they should be also be read in conjunction with the user information provided with the remote key fob unit and the warnings given in relevant sections of the user manual

WARNING!

Because the remote key fob sender unit can immobilise the powered wheelchair without the prior notice of the user, it must be only be used by a responsible adult. The key fob should not be left unattended, and must not be left within reach of un-authorized persons or children.

WARNING!

Before and each and every time the wheelchair is used the attendant/carer must establish that the remote stop function is operating satisfactorily before proceeding with its use.

User warnings and limitations of use:

NOTE / CAUTION!

Control of the powered wheelchair remains with the user however when the button on the remote unit is pressed the powered wheelchair's electronic drive inhibit function will be activated. This will bring the powered wheelchair to a controlled stop if it is moving, and will prevent the user from driving the chair in any direction. The inhibit function will be deactivated when the remote button is pressed once more.

NOTE / CAUTION!

Care should be taken to ensure the powered wheelchair is not immobilised in a dangerous environment or position in use. (E.g. on crossing a road or level crossing)

WARNING!

Although the drive inhibit function will bring a powered wheelchair to a controlled stop Sunrise Medical Ltd strongly recommends the fitting of a lap belt or harness to the chair, and that the user should wear it at all times when occupying the chair.

NOTE / CAUTION!

The stopping of the wheelchair is in a controlled manner, therefore it must be recognised that there is a finite distance to stop the wheelchair and it is not an emergency stop (dead stop).

NOTE / CAUTION!

The remote stopping functionality of the wheelchair is wholly dependent on the integrity of the radio communications link between the transmitter (key fob) and the receiver (wheelchair). If the integrity of the communications link is broken or corrupted, it may not be possible to stop the wheelchair. Sources of communications disruption may be caused by but not limited to-

- The battery power of the transmitter or receiver is not sufficient to maintain communication.
- The environment obstructs the transmitted signal, e.g. the wheelchair must be in direct line of sight, or absorbs the transmitted signal, e.g. large metallic objects close by.
- The distance between the transmitter and the wheelchair exceeds the range of the transmitting / receiving devices.
- Other interfering radio transmitting devices, e.g. garage door remote controls, mobile phone, radio transmitting towers, emergency services communications, power distribution cables.
- Environmental effects; electrical storm, rainwater ingress into the transmitting/ receiving devices.

3.0 Intended use of the wheelchair

General description



The Q300 range is a modular power wheelchair. A feature is the suspension system that allows you to have an ideal driving experience indoors as well as outdoors.

Due to its modular design, simplicity and wide range of adjustments, the Quickie Q300 series is a perfect choice for easy service, refurbishment and recycle requirements.

The Q300 series fulfils individual preferences, needs or circumstances and is available in the following configurations:

- Midwheeldrive (MWD): Q300 M Mini

To have optimum seating support and individual adjustments the Q300 series is available in combination with

- Sedeo Lite seating system (refer to seating manual )
- Sedeo Pro seating system (refer to seating manual )
- Zippie Kids / Quickie Teens seating system (refer to seating manual )

3.1 Area of application: The user

Power wheelchairs are exclusively for a user who is unable to walk or has limited mobility, for their own personal use indoors and outdoors. Driving a powered wheelchair requires cognitive, physical and visual skills. The user must be able to estimate and correct the results of actions when operating the wheelchair.

The wheelchair cannot transport more than 1 person at a time. The maximum weight limit (includes both the user and any weight of accessories fitted to the wheelchair) is marked on the serial number label, which is affixed to the chassis of the chair (Fig. 2.9).

For restrictions on user weight limit refer to seating manual .

The user must be informed of the contents of this user manual before driving the wheelchair. In addition, the user of the wheelchair must be given thorough instruction by a qualified specialist before he or she participates in traffic. The first sessions in the wheelchair should be practiced under supervision of a trainer/advisor.

Indications

The varieties of fitting variants, as well as the modular design, mean that it can be used by those who cannot walk or have limited mobility because of:

- Paralysis
- Loss of extremity (leg amputation)
- Extremity defect deformity
- Joint contractures/joint injuries
- Illnesses such as heart and circulation deficiencies, disturbance of equilibrium or cachexia as well as for elderly people who still have strength in the upper body.

Contraindications

The wheelchair shall not be used in case of:

- Perception disorder
- Imbalance
- Seating disability

Fig. 3.1

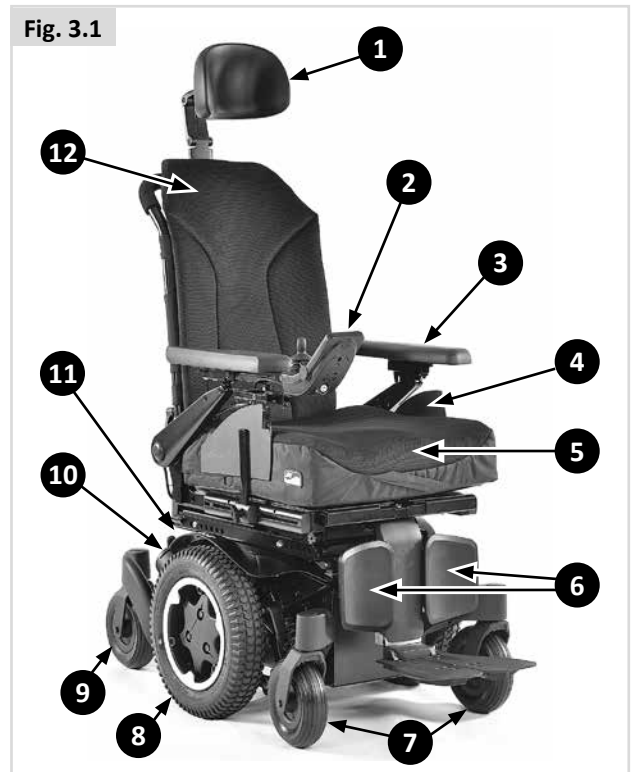

Please note that driving a wheelchair requires sufficient cognitive, physical and visual skills. The user must be able to assess the effects of actions during the operation of the wheelchair and, if necessary, to correct them. These capabilities and the safe use of the additionally attached components cannot be assessed by Sunrise Medical as a manufacturer. We cannot accept any liability for any damage resulting from this.

Please refer to the operating instructions of the wheelchair and the additionally mounted components. Instruct the user in the safe use of the wheelchair and the additionally mounted components. Inform users of specific warnings that need to be read, understood, and respected.

Basic Components (Fig.3.1).

- | | |
|-----------------|---------------------|
| 1. Headrest | 7. Front Castor |
| 2. Joystick | 8. Drive Wheel |
| 3. Arm Rest | 9. Rear Castor |
| 4. Side Cushion | 10. Motors |
| 5. Seat Cushion | 11. Battery Box |
| 6. Leg Rest | 12. Back Upholstery |

⚠ WARNING!

- If you are under the influence of medicines that can have an effect on your ability to drive, you are not permitted to drive a wheelchair.
- Adequate vision is required in order to safely operate a wheelchair in the user situation concerned.
- Not more than one person at a time can be seated in the wheelchair.
- Do not allow children to ride in the wheelchair unsupervised.

⚠ CAUTION!

- The user of the wheelchair is at all times completely responsible for complying with the applicable local safety regulations and guidelines.

Attendants

When an Attendant Control Module is fitted, the Power Wheelchair may be operated by an assistant on behalf of the user.

When a Dual Control Module is fitted the Power Wheelchair may be operated by the user, or control may be switched to an assistant to operate on behalf of the user.

- Make sure you heed all warnings and follow all instructions in each section of this manual. Warnings that apply to the user also apply to you.
- Do not stand or sit on any portion of this seating system.
- You need to work with the user, and the user's doctor, nurse or therapist, to develop safe methods best suited to your abilities and those of the user.
- Check to make sure push handle grips will not rotate or slip off.
- Make sure you always have comfortable access to the attendant controls while the chair is moving and make sure that the controller is fixed securely to the chair.
- Set the speed of the attendant control to a speed that you can comfortably follow.
- Always turn off the power to the controller when leaving the user in the chair.

3.2 Area of application: The user environment

This wheelchair has been designed to accommodate both indoor and outdoor use (EN12184 (2014) Class B). When driving the wheelchair outdoors, drive only on paved roads, pavements, footpaths and bicycle paths. The speed must be adapted to suit the environment.

⚠ WARNING!

- Drive carefully on slippery roads resulting from rain, ice or snow!
- You are required to turn on the lights in case of limited visibility.
- When driving at higher speeds you must be extra careful. Select a lower maximum speed indoors, on the pavement and in pedestrian areas.
- Do not drive off high obstacles.
- Do not attach a weight to the wheelchair without the approval of a qualified specialist. This may negatively affect the stability of the product.

⚠ CAUTION!

- Prevent the wheelchair from coming into contact with sea water: sea water is caustic and may damage the wheelchair.
- Prevent the wheelchair from coming into contact with sand: sand can permeate into the moving parts of the wheelchair, causing extensive wear on these parts.
- Do not use the wheelchair if temperatures are below: -25°C or above $+50^{\circ}\text{C}$.
- Do not open doors using the leg rests.
- Do not push and/or tow any objects with the wheelchair.
- Do not drive through puddles of water.

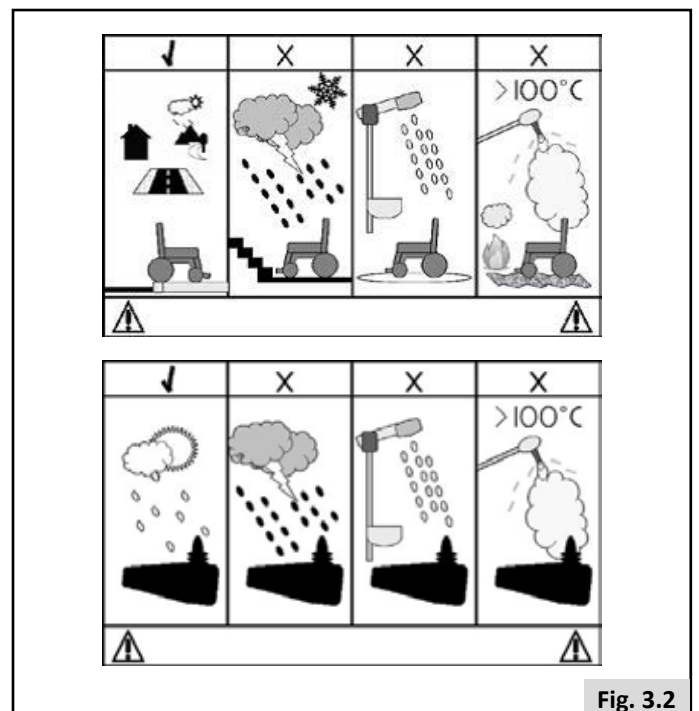



Fig. 3.2

4.0 Setting up the wheelchair

Sunrise Medical wheelchairs can be adjusted according to specific needs of the user.

In this, we make a distinction between wheelchair settings and wheelchair seating adjustment options. Settings are carried out once, the first time the wheelchair is going to be used. They must be executed by qualified specialist, unless explicitly stated otherwise. Seating adjustment options can be carried out by the user. These adjustment options do not require the use of tools.

4.1 Seating system

The extensive settings with respect to the seating system allow for optimum support of the body ( Seating system). The following setting options are possible:

1. Seat depth and seat width
2. Backrest angle
3. Armrest height/width
4. Lower leg length
5. Angle of the footplate
6. Legrest angle

4.2 Seat height

Depending on the specific circumstances of the user of the wheelchair the seat height can be set. Every optional seat height lies within the rated slope as described in EN12184 (2014) Class B. Lowering the seat height has a positive influence on the (dynamic) stability.

WARNING!

Increasing the seat height has a negative effect on dynamic stability.

4.3 Centre of gravity

DANGER!

Adjusting the centre of gravity on a powered wheelchair is both physically demanding and safety critical. Sunrise Medical recommends that this adjustment is only performed by a service agent/dealer approved by Sunrise Medical.

4.4 Controller height and depth

( Seating system).

4.5 Control system programme

This wheelchair is equipped with a control system that can be programmed by adjusting settings within the system. This is a specialized job that needs training and can only be adjusted with professional software. The end user is not allowed to adjust these settings.

DANGER!

The incorrect setting of the parameters for the control system may result in very dangerous situations. Settings must be made by qualified specialists.

4.6 Lap strap / seating positioning belt

DANGER! / WARNING!

- This product is only to be used to position a single person in a wheelchair.
- Lap straps are not suitable for transit purposes, approved occupant restraint systems must be used.
- Failure to heed these warnings may result in severe injury or death.
- Ensure that the carer or attendant is trained in the correct operation of the belts.
- Untrained carers or attendants may lead to delays, if an emergency situation occurs.

Mounting a lapstrap / seating positioning belt

1. Attach (A) to the seating frame using a screw on the left and on the right. (Fig 4.2)

Positioning a person with a lapstrap

- Adjust the lap strap to suit, leaving no more than a hand's width gap for comfort and safety (Fig 4.3).
- The hand clearance should be with the lap strap under normal tension and not allow large gaps or loops.
- Generally, the lap strap should be fixed so that the straps sit at an angle of approximately 45° (Fig. 4.4), and when correctly adjusted should not allow user to slip down in the seat.
- Place the strap loosely across the seat with the opening end of the buckle facing to the right for a left-handed person and to the left for a right-handed person. Pass the other ends of the strap through the gap between the backrest posts and the backrest.

DANGER! / WARNING!

- Always make sure that the lap strap is correctly secured and adjusted prior to use.
- If a strap is too loose it could cause the user to slip down and cause serious injury.
- Check lap strap and securing components at regular intervals for any signs of fray or damage. Replace if necessary.
- When servicing, check for correct operation of the release buckle and for any signs of wear on the material or plastic brackets.
- Regular Checks/Activities:
 - As with all positioning components, there is a need for corrective adjustments as the person changes their seating position over time.
 - Check the belts regularly for correct fitting, to ensure the safety and comfort of the user.

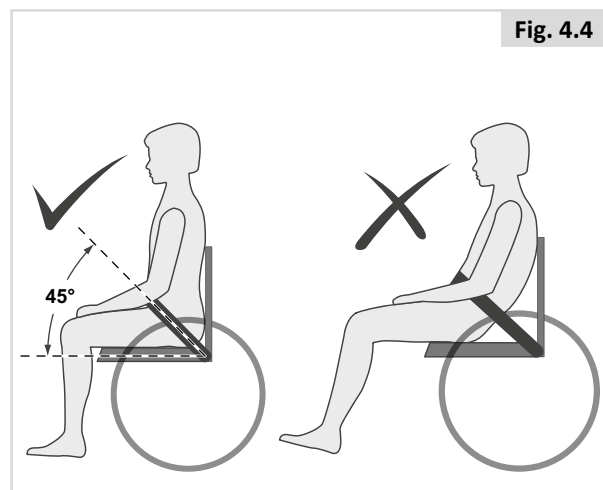
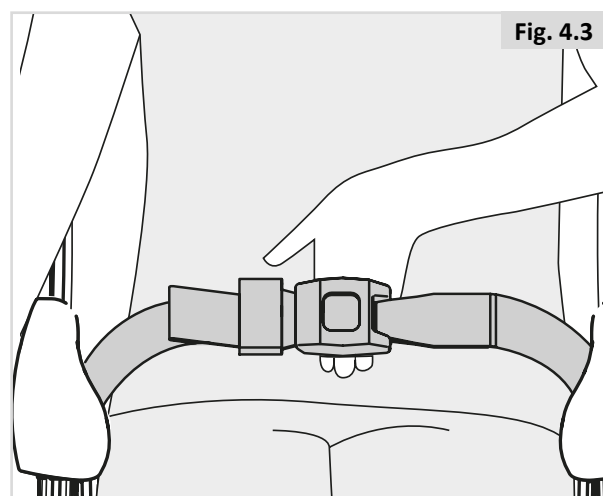
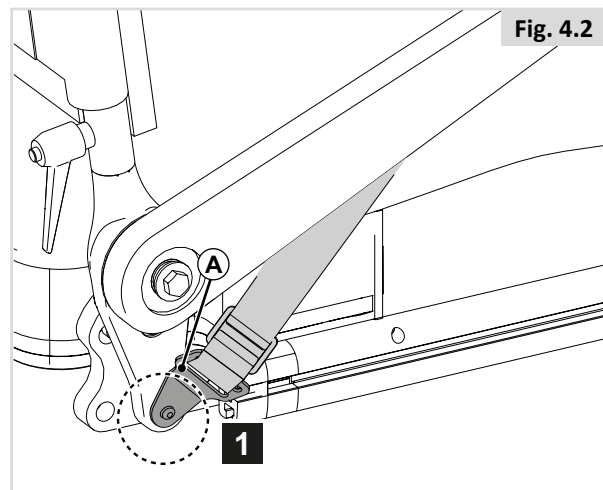
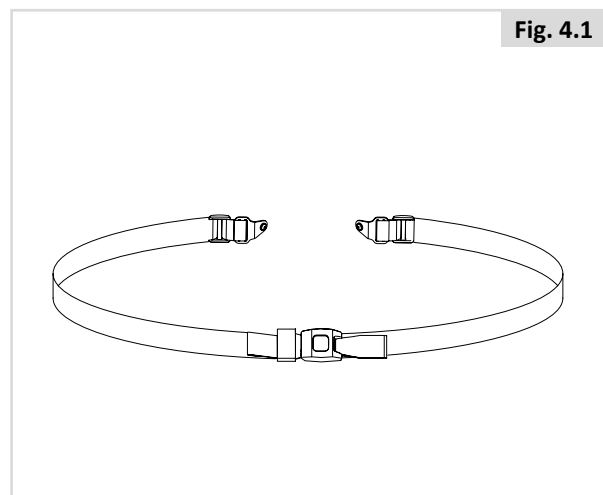

5.0 Using the wheelchair

DANGER!

- Be aware that you may need to adjust the controller settings of your system.
- Consult your authorised dealer to adjust the control settings immediately if you notice any change in your ability to:

1. Control the joystick
2. Hold your torso erect
3. Avoid running into objects.

5.1 Checking wheelchair before use

Perform the following daily check routine before driving:

CAUTION!

Checking wheels & tyres

- Are the tyres sufficiently inflated (Chapter 8.2).

Checking batteries

- Before using your vehicle for the very first time, please charge your batteries for a period of 24 hours.
- Are the batteries sufficiently charged? The green lights on the battery indicator must be on.  Controller

Checking lights and indicators

- Ensure that the lights and indicators are functioning correctly and lens are clean before going outdoors at night.
 Controller

Checking remote

- With the control system switched off, check that the joystick is not bent or damaged and that it returns to the centre when you push and release it.

Checking free wheel lever

- Ensure that the free wheel lever has been set to 'drive'. (Chapter 5.8).

Checking seating

- Ensure that all the cushions are in place.
- Make sure that the backrest is correctly fitted and adjusted.
- Visually inspect the wheelchair to make sure the leg rests, armrests etc. are correctly positioned and attached to the wheelchair and all fasteners are sufficiently tightened.
- Ensure that the seat interface knobs are tight and secure.

Checking clothing on potential entrapment

- When operating the wheelchair, ensure that your clothing does not hamper the wheelchair (i.e. too long). Before use, always check if your clothing or accessories do not come into contact with the wheels or and other moving and/or rotating parts in which they could become entangled.

Checking weather conditions

- In winter, batteries have a reduced capacity. During a period of light frost, the capacity is roughly 75% of the normal capacity. At temperatures below -5°C this will be roughly 50%. This will reduce your range of action.

WARNING

Avoid wearing loose cuffs/sleeves when operating joystick as the joystick could get caught up.

WARNING

If the foot plate rubs on the floor during use please be aware this may make the front edge sharp and therefore lead to injury. Therefore handle with care and replace the footrest if it becomes sharp.

5.2 Making a transfer

Sunrise Medical recommend that you consult your healthcare professional for assistance in developing your personal front or side transfer technique to best suit your needs and avoid any personal injury.

Preparing for a forward transfer:



It is dangerous to transfer on your own. It requires good balance and agility. Be aware that there is a point during every transfer when the seating system seat is not below you.

For further instructions and warnings about making a transfer, please refer to  Seating system.

5.3 Driving the wheelchair



- The user of the wheelchair is at all times completely responsible for complying with the applicable local safety regulations and guidelines.

Powered wheelchairs are driven by means of a controller. There is a separate user manual for the controller and this was included with this wheelchair ( Controller).

1. Switch on the controller.
2. Set the maximum speed limit.
3. Move the joystick in the direction in which you would like to go.
4. Moving the joystick even further forwards will cause the wheelchair to drive faster.

Rear view mirror



- To avoid injury to people around you please be aware that the mirror protrudes outside the space envelope of the chair and could cause injury to someone when driving past.
- The mirror must be used on models at speeds over 6 kph on roads according to local law.
- Always make sure that when using the mirror that it is clean and unbroken so that it does not impair your visibility.

Road use

Please show the utmost consideration for the other traffic on the road.

DANGER!

- Remember that the last thing a car or lorry driver expects to see is a wheelchair backing off the kerb into the road.
- If in any doubt, do not risk crossing the road until you are certain that it is safe.
- Always cross the road as quickly as possible, there may be other traffic.
- Do not drive over anything that could cause punctures in the tyres.
- Ensure that there are no objects in your path that could possibly become lodged in your chair mechanism or in the spokes of the rear wheels. This could cause the chair to come to a sudden stop.
- Riding over drains or grids could cause the wheelchair castors or wheels to become lodged, causing the chair to come to a sudden stop.

Adverse conditions:

Please be aware that when driving your wheelchair in adverse conditions, e.g. on wet grass, mud, ice, snow or other slippery surfaces, you may experience a reduction in the grip and traction of your wheelchair.

DANGER!

- We recommend you take extra precautions in these conditions, particularly on hills and slopes; your wheelchair could become unstable or skid causing possible injury.
- When you are using a Powered Wheelchair take extra care with loose or long items of clothing. Moving parts, such as wheels, can be potentially dangerous or even fatal if clothing becomes entangled.

NOTE :

Extreme variances in temperature may trigger the self protect mechanism in the control system. If this occurs the control system will temporarily shut down to prevent damage to the electronics or the wheelchair.

5.4 Curves

DANGER!

Full speed turns should not be attempted. If you need to turn sharply you must reduce your speed with the joystick or speed setting. This is particularly important when travelling across or down a slope. Disregarding this advice could lead to your wheelchair tipping over.

WARNING!

Use indicators when changing direction.

5.5 Braking & Emergency stop

There are three ways to stop your wheelchair:

- Simplest and safest way to stop the wheelchair is to release the joystick. This will bring the chair to a halt in a controlled manner.
- Pulling back the joystick will break the chair abruptly with a fast stop.
- Switching the control system off whilst the chair is in motion will also bring the chair to a halt.

WARNING!

- Switching the control system off is only to be used in an emergency situation as the stopping action is very abrupt.

5.6 Driving on a slope

Your wheelchair has been designed and tested to allow its use on slopes or gradients of at least 8°.

Q300 M Mini: 8° (14%) in standard configuration.

However, you have the option of adjusting your position with the seat elevator, tilt in space, powered recline or powered centre mount leg rest or a combination of these options.

DANGER!

- Elevating, tilting and leg rest adjustments can affect the wheelchair centre of gravity. Under certain conditions this might cause instability that could lead to unintentional tipping. It may be necessary to carry out a risk assessment if the wheelchair is adjusted to extremes.
- Stopping distances on slopes can be significantly longer than on level ground.

DANGER!

- In certain circumstances your wheelchair could become unstable.
- Before attempting to climb or descend a slope or a kerb, caution should be taken when using weight shift options (e.g. powered, recline or standing), of the seat and/or your body for a counter balance weight.
- To improve stability lean forward when driving uphill, with the seat and back in an upright position.
- Alternatively sit in an upright position when travelling in a forward, downhill direction or and/or recline the seat backwards.
- We strongly recommend that you return the seat and back to their home positions before attempting to climb or descend a slope. Failure to do this may cause the wheelchair to become unstable.
- If you are in any doubt about the capabilities of your wheelchair on a slope then do not attempt to drive up or down the slope/kerb; try to find an alternative route.

Gradients: ascents:

WARNING!

- When going uphill, keep the chair moving.
- Steer by carefully moving the joystick forwards making slight Left and Right adjustments as you go.
- If you have stopped on a hill, you should start slowly.
- If necessary lean forward.

Gradients: descents:

On descents, it is important not to let the wheelchair accelerate beyond its normal level of ground speed.

DANGER!

- Proceed slowly down steep descents, (below the speed of 5kph) and stop if you feel anxious.
- If the chair picks up speed, centre the joystick to its home position to allow it to slow, or to stop.
- Restart slowly and do not allow the speed to increase above what you are comfortable with.

NOTE:

- The controller has the benefit of a logic system that will help compensate when driving along a camber or up a hill. This is an added safety feature on your wheelchair. In addition of course, you may control the wheelchair speed by using the speed control.

5.7 Obstacles & kerbs:

DANGER!

- Never descend a kerb backwards.
- Do not attempt to climb or descend a series of steps or use on escalators. It is unsafe to do so and could cause personal injury or damage the chair. This wheelchair has only been designed to climb a single step or kerb.
- We recommend that users with upper trunk instability wear restraint systems to keep the upright body position during descending or ascending ramps, kerbs or obstacles.

Kerb climbing:

Always approach a kerb at 90° (Fig. 5.1).

- Approach the kerb or step, head on at a 90° angle.
- Drive forwards slowly and steadily.
- Stop the chair as soon as the castor wheels touch the kerb.
- Apply sufficient power to the motors to lift the front of the chair up onto the kerb or step and then apply slightly more power until the drive wheels climb the kerb or step smoothly.
- As far as possible, keep the joystick in the straight forward position.

The maximum obstacle or kerb climbing height is:

- Q300 M Mini: 70 mm.

The approach speed and process can vary depending on your wheelchair drive type and castor wheel choice.

Dismounting the kerb.

DANGER!

Move the chair slowly and carefully in a forward direction until both front wheels are on the edge of the kerb, again in a 90° position to the kerb.

Drive as slowly as possible off the kerb with the drive wheels. Don't stop the chair during descent of the kerb. You will feel more secure if you can lean backwards, but if you can't, don't worry, the wheelchair is stable. As long as you stay within its limitation, you will be quite safe.

All powered seating options need to be in home position. Your powered leg rests may need to be adjusted to give enough clearance to mount or dismount the kerb.

We recommend to use the lap strap to feel more secure during declining the kerb. For extra protection we recommend to fit every chair with the leg rests.

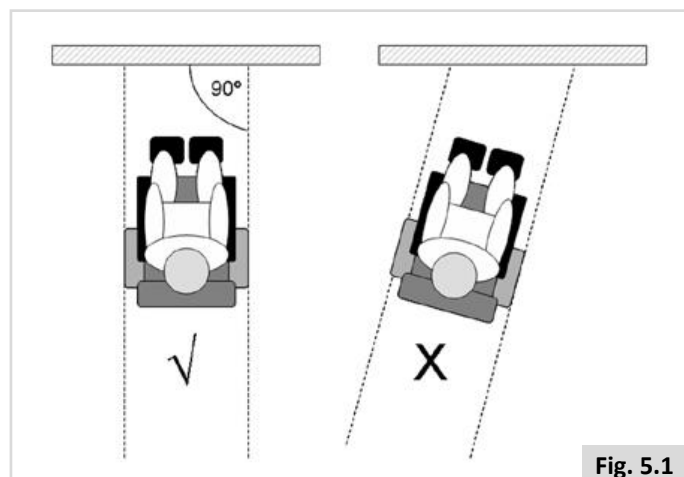

Fig. 5.1

5.8 Pushing the wheelchair

The wheelchair can be moved by pushing. In order to do so, the motors must be disengaged using a freewheel lever. This feature was developed for the attendants of wheelchair users and also functions as an emergency freewheel lever. The freewheel lever has 2 positions:

1. For driving the wheelchair.

'Drive' position: Turn the lever so that the lever at the drive wheel side is positioned as shown below (Fig. 5.2 - Fig. 5.3 or Fig. 5.6).

2. For disengaging the motors.

'Push' position: Turn the lever so that the lever at the drive wheel side is positioned as shown below (Fig. 5.4 - Fig. 5.5 or Fig. 5.7 - Fig. 5.8).

DANGER!

- The free wheel lever should only be operated by the attendant and never by the user.
- A user may never be left unattended while the wheelchair is in 'push' (Fig. 5.4 - Fig. 5.5).
- Never set the lever to the 'push' position on a slope! When the freewheel lever is set to 'push', the automatic parking brake is deactivated. This makes it possible for the wheelchair to roll down the slope (Fig. 5.4 - Fig. 5.5).
- The automatic parking brake only works if the lever is set to 'drive' position.
- When the wheelchair is no longer being pushed, the freewheel lever should be set to 'drive' immediately.
- To manually push the system you must release the motor brakes.
- Do not engage or disengage motor brakes unless power to the system is off.
- Make sure you have full control over the system when you release the motor brakes. When you do so the system will not have brakes.
- Make sure the system is on level ground before you release the motor brakes.
- Propel this system by the push handles only. They provide secure points for you to hold the rear of the system to prevent a fall or tip-over.
- Check to make sure push handle grips will not rotate or slip off.

Fig. 5.2

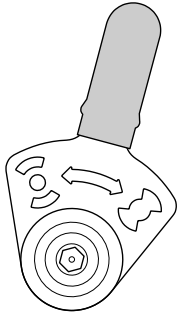
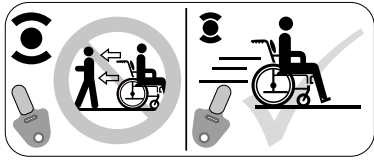

Left-hand side 'Drive'

Fig. 5.3

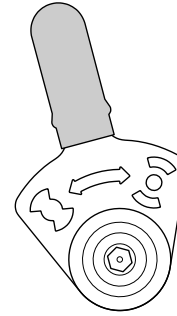
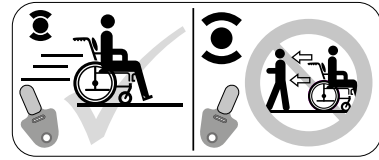

Right-hand side 'Drive'

Fig. 5.4

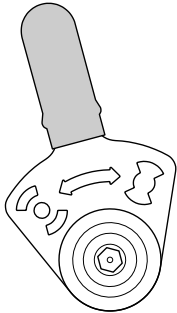
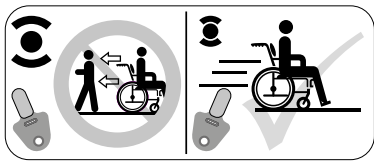

Left-hand side 'Push'

Fig. 5.5

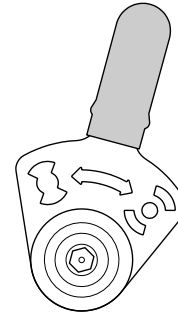
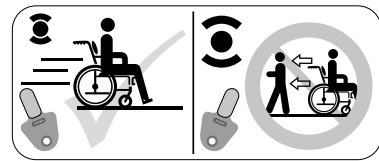

Right-hand side 'Push'

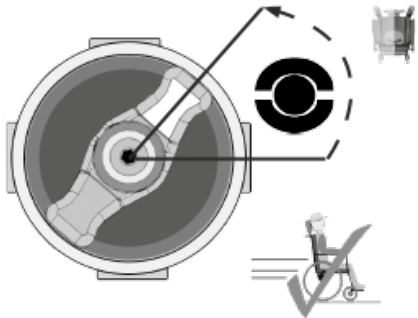

Fig. 5.6

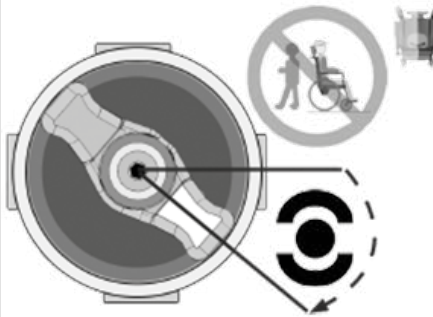

Fig. 5.7

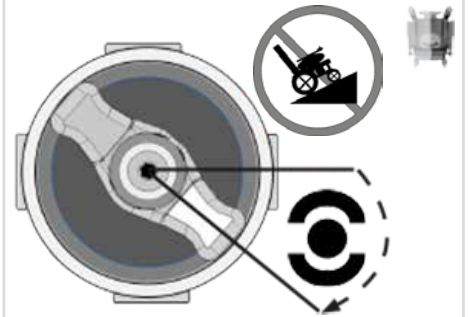





Fig. 5.8

5.9 (Powered) seating options

The wheelchair can be equipped by the following mechanical and/or powered options to adjust your seating position. These options can be operated by the user without the use of tools.

Powered adjustable seating options (Fig. 5.9 - Fig. 5.11).

How to operate these powered seating options can be found in  Controller +  Seating:

Controller +  Seating:

1. Powered tilt function
2. Powered seat elevator
3. Powered backrest recline
4. Powered elevating leg rests

The wheelchair may be equipped with a feature that allows the powerchair to be driven up to 4.5kph/3mph when the seat is elevated, this feature is called C-Me. For guidance with user weight limits and recommended chair configuration when using C-Me, please refer to your Sunrise Medical authorized dealer.

DANGER!

- Use of the powered adjustable seating options may influence the stability of the wheelchair.
- Only use the powered adjustable seating options when the wheelchair is on a flat surface! Do Not attempt to operate any power seating option while positioned on an incline.
- Please stay clear of any powered actuator while the component is in motion. Sunrise power mechanisms move over large ranges of travel. Users should be aware of their surroundings while components are in motion.
- While driving this seating system in the reclined, elevated, or tilted position use caution.
- Do Not attempt to operate any power seating option while this seating system is in motion.
- Do not attempt to operate the lift or tilt power seating options around children.
- Through programming it is possible to reverse the direction of all powered seating functions, ensure you know which direction your seat is going to move before operating.
- Please be aware that the lift/tilt modules present a trap hazard. Make sure that during operation the lift/tilt modules are free from all clothing, hands, feet and other extremities, to prevent injury.
- Do not drive on ramps or slopes with the seating in the elevated position. Before attempting to climb or descend a slope, return the wheelchair to a standard seated drive position, with the backrest upright.
- This power system is designed to automatically reduce the maximum driving speed to a creep and/or C-Me mode when certain power seating limits are reached. Depending on the configuration of the chair there might be multiple creep and/or C-Me speeds.
- Before operating your chair in creep and/or C-Me mode, read all warnings and guidelines related to this feature. They will help in understanding how to reduce the risk of a fall or tip-over and how to identify environmental conditions that could affect your safety when driving while the chair is in creep and/or C-Me speed.
 1. When driving indoors or outdoors, in creep mode, it should only be used on flat, level, and hardscape surfaces.
 2. Driving in creep mode should never be attempted on uneven terrain like: gravel, grass, bumpy surfaces, uneven pavement, or hills.
 3. NEVER raise the seat when the chair is being operated in the proximity of any of the terrain types listed above, or on any uneven surface.

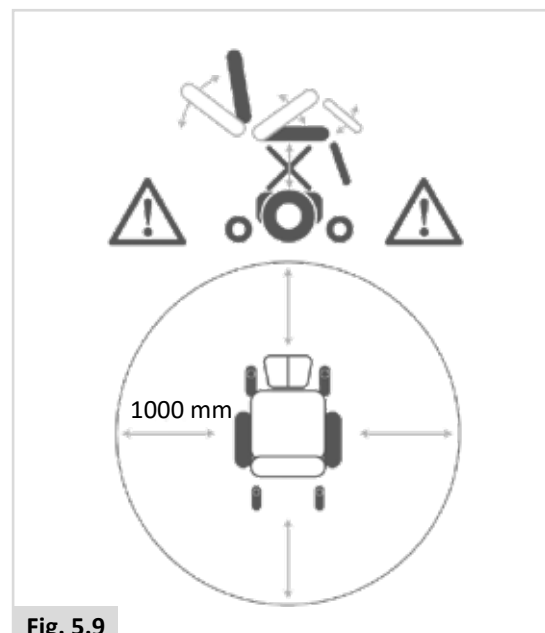

Fig. 5.9

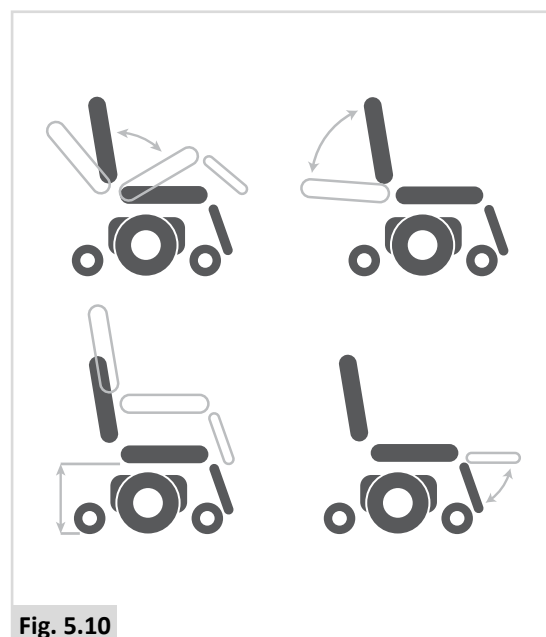

Fig. 5.10

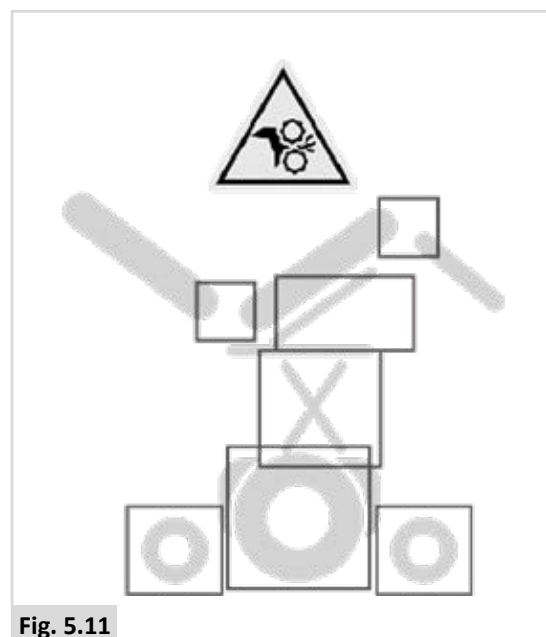
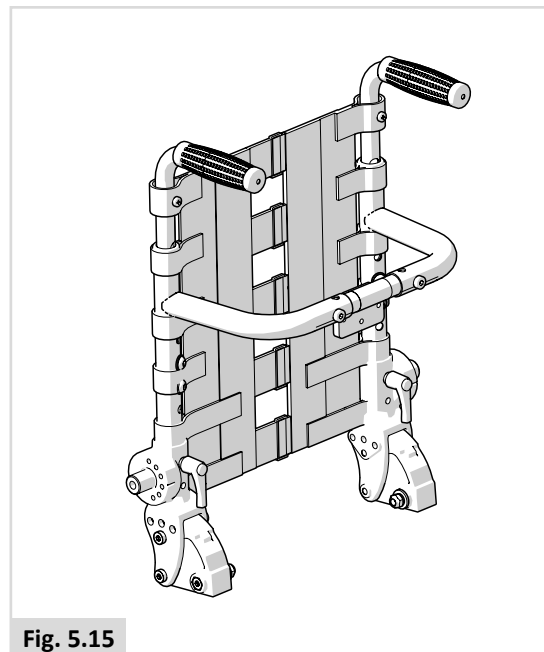
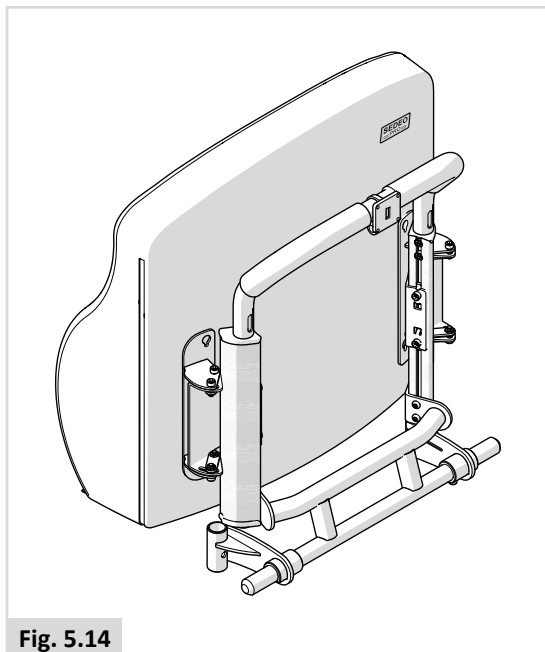
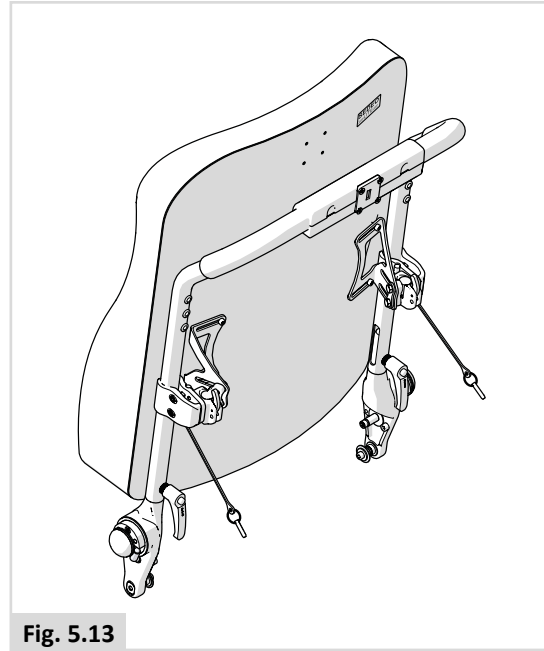
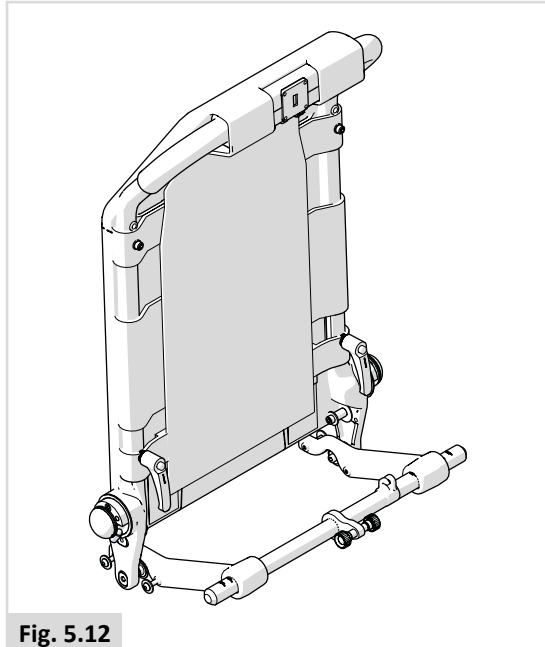

Fig. 5.11

5.10 Different Backrest Configurations

The available backrest configurations are shown below as:

- Standard (Fig. 5.12)
- Sedeo Lite (Fig. 5.13)
- Sedeo Pro Back Cushion Flexible (Fig. 5.14)
- Quickie Teens / Zippie Kids (Fig. 5.15)



6.0 Batteries, charging and range

6.1 Batteries

Batteries are the power source for almost all of the modern mobility products available today. The design of batteries used in mobility products is significantly different to the batteries used to start a car for example. Car batteries are designed to release a large amount of power over a short period of time, whilst mobility batteries (commonly called deep cycle batteries) release their power evenly, over a long period of time. Therefore, due to the lower production volumes and increased technological requirements, mobility batteries are typically more expensive.

Commonly two 12 volt batteries are used together in a mobility product, giving a total voltage of 24 volts. The size of the battery (e.g. its available power) is expressed in amps per hour e.g. 70amp/hr. The higher the number, the bigger the battery size, weight and, potentially, the greater the distance you can travel. Sunrise Medical only fit as standard maintenance free batteries into these types of wheelchairs. This type of battery uses a method of carrying the electrolyte commonly referred to as 'AGM', that is held within the battery case. As the name implies, no maintenance is required other than regular charging. You can safely transport this type of battery without fear of acid spilling. **Furthermore, they are approved for transportation on aircraft, trains and ships.**

⚠ CAUTION!

- Do not fit car batteries to the wheelchair. Fit only deep cycle, maintenance free mobility batteries.
- When the batteries are worn out, take them to the local authority disposal point.
- Do not expose any part of the battery to direct heat (i.e. naked flame, gas fire).
- Be extra cautious to reduce the risk of dropping a metal tool onto the battery. It could spark or short circuit the battery or other electrical parts that may cause an explosion. Also take off all personal metal effects and dangling objects when working on the battery.
- Return the batteries back to Sunrise Medical or directly to the battery manufacturer for recycling, when they no longer hold charge.
- The battery terminals need to be checked regularly for signs of corrosion. If any corrosion is apparent, then clean the terminals completely and re-grease the terminal using Vaseline petroleum jelly, not ordinary grease. Ensure that the terminal nut and bolt, cable clip and exposed cable are completely covered with jelly.

⚠ DANGER!

- Do not expose any part of the battery to direct heat (i.e. naked flame, gas fire).
- Be extra cautious to reduce the risk of dropping a metal tool onto the battery. It could spark or short circuit the battery or other electrical parts that may cause an explosion. Also take off all personal metal effects and dangling objects when working on the battery.

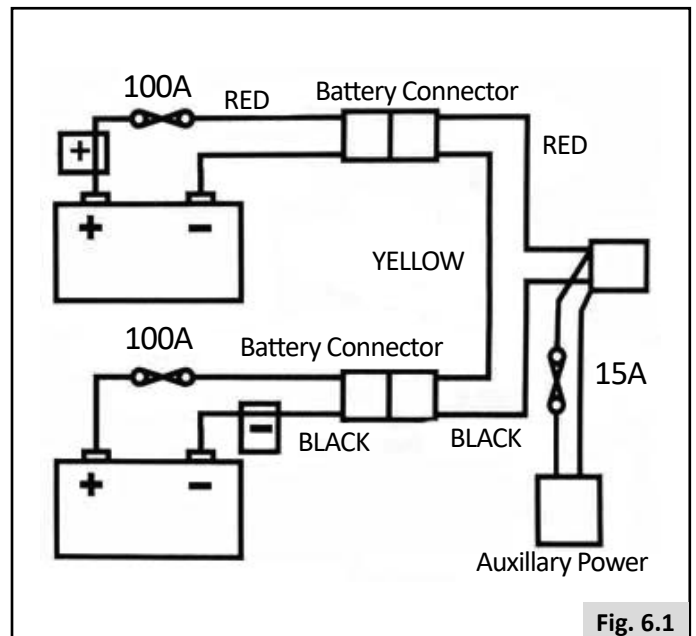

⚠ DANGER!

- Do not, under any circumstances, tamper with the batteries. If in any doubt contact your local Sunrise Medical authorised dealer.
- Avoid contact with acid on damaged sealed type batteries or wet batteries.
- Battery acid can cause burns to the skin as well as damage to floors, furniture and your wheelchair.
- If battery acid comes into contact with the skin or clothing, wash immediately with soap and water.
- If battery acid comes into contact with the eye, immediately flood the eye with running cold water for at least 10 minutes and seek medical attention immediately.
- Acid spills can be neutralised with baking soda and water.
- Take care to keep batteries upright at all times, especially when transporting your wheelchair.

Safety cut-outs

In the event of a short circuit there are several safety systems built into your wheelchair to safeguard your electrical circuits, (Fig. 6.1).

1. Fusible 100A links are connected into the battery harnesses to protect the batteries and wiring.
2. 15A auxiliary power circuit fuses for auxiliary modules and seating power supply.

To replace them contact your Sunrise Medical authorised dealer, who will also diagnose the original fault.

6.2 Charging batteries:

 Battery charger: Please read the owner's manual with the charger supplied carefully. The general procedures and effects for the interference with the chair and the batteries remain valid.



Battery care plan

Below is set out a battery care plan for maintenance free batteries. This has been agreed between Sunrise Medical and the battery manufacturers, to enable you to get the best out of your batteries. If a different care plan is followed, this may result in lower than expected performance from your mobility vehicle.

- Only use an approved Sunrise Medical charger compatible with the vehicle to be charged.
- Charge your batteries every night, regardless of the amount of use your mobility device has had during the day.
- Charge the batteries in a well ventilated area.
- Do not interrupt the charging cycle.
- If your mobility device is not required for use, it should remain connected to the charger until required. This will not damage your batteries, as long as the mains socket/plug is left switched on. Turning the mains socket/plug off, but leaving the mains cable plugged in will eventually deplete your battery charge.
- If you leave your vehicle for an extended period (more than 15 days) charge the batteries fully and then disconnect the main battery lead.
- Failure to allow for recharge will damage the batteries and can lead to shortened distances and premature failure.
- Do not top up the charge of your batteries during the day. Wait until the evening for a full overnight charge.
- As a general rule, maintenance free batteries take longer to fully charge than "wet" lead acid batteries.
- The battery terminals need to be checked regularly for signs of corrosion. If any corrosion is apparent, then clean the terminals completely and re-grease the terminal using Vaseline petroleum jelly, not ordinary grease. Ensure that the terminal nut and bolt, cable clip and exposed cable are completely covered with jelly.
- Following all the points above should result in a healthier battery, greater range for the vehicle user and a longer life for your batteries.

Connecting the battery charger

Procedure for connecting the charger and charging

- Switch off the wheelchair controller.  Controller:
- Connect the battery charger round output plug to the charging socket on the front of the joystick module.  Controller:
- Connect the charger to the mains supply by means of the mains plug and switch on.

For more information about the charger operation, consult the instructions provided with the charger.  BATTERY CHARGER. Depending on how depleted the batteries are, it may take up to 12 hours to fully charge the batteries again.

DANGER!

- Make sure the cord is located so that it will not be stepped on, tripped over or otherwise subjected to damage or stress.
- Do not rest a battery on top of the charger.
- Do not stand the charger on a carpet or other soft surface. Always place it on a hard flat surface.
- Do not operate the charger if it has received a sharp blow, been dropped or otherwise damaged in any way. Take it to a qualified technician.
- Never place the charger directly above the battery being charged; gases from the battery will corrode and damage the charger.
- Never charge a frozen battery. A fully charged battery will rarely freeze but the electrolyte of a discharged battery can freeze at -9° Centigrade. Any battery that is suspected of being frozen should be thawed completely before charging.
- Never sit with the charger on your lap when charging your batteries
- The charger casing will get hot during its normal operation.
- Do not disassemble charger; only have it repaired by the manufacturers. Incorrect re-assembly may result in a risk of electric shock or fire.
- To reduce the risk of an electric shock, unplug the charger from the outlet before attempting any maintenance or cleaning. Turning off the controls will not reduce the risk.
- Never smoke or allow a spark or flame in the vicinity of battery or charger.
- You should not charge your batteries in outdoor conditions.
- It is advised to use a smoke detector in the charging area.

Battery Charger

The external charger has been designed to charge two 12V AGM batteries connected in series (= 24 V).

The chargers have features which prevent hazards or accidents occurring as a result of connecting batteries the wrong way round, overheating caused by fault conditions or attempting to charge wrong voltage batteries.

The majority of charger sizes are electrically double insulated and no earth connection is required. Some larger sizes may be electrically earthed and this will be clearly stated on the label.

If your charger has been specified for use in Continental Europe it will contain a European two pin plug which does not have a fuse. In this case the fuse is located in the fascia panel of the charger.

Country specific information: UK

The 3 pin UK mains input plug contains a replaceable fuse. The rating of this fuse is shown on the charger label.



- As with all mains powered electrical equipment, always replace blown fuses with the same type and size of fuse as specified.
- Fitting of different fuses can result in an increased fire risk, damage to the charger or failure of the charger to operate properly.

6.3 The range of your vehicle:

Please refer to the specification tables at the back of this manual for Energy Consumption, (Maximum Range), information.

Most manufacturers of mobility products state the range of their vehicles either in the sales literature or within the Owner's Manual. The range stated sometimes differs from manufacturer to manufacturer even though the battery size is the same. Sunrise Medical measure the range of their vehicles in a consistent and uniform manner, but variances still occur due to motor efficiencies and overall product load weight.

The range figures are calculated to I.S.O. Standard 7176. Part 4: Wheelchair Energy Consumption Theoretical Range.

This test is carried out in controlled conditions with new, fully charged batteries, on a level test surface and a user weight of 100 kg. The range figures stated should be seen as a theoretical maximum and could be reduced if any single, or combination, of the following circumstances occur:

- User weight heavier than 100 kg.
- Batteries whose age and condition are less than perfect.
- The terrain is difficult e.g. very hilly, sloping, muddy ground, gravel, grass, snow and ice.
- The vehicle climbs kerbs regularly.
- The ambient temperature is very hot or very cold.
- Incorrect tyre pressures in one or more tyres.
- Lots of start/stop driving.
- Also thick pile carpets within the home can affect range.
- Use of additional power consumption options (e.g. light, actuators, etc.)

The battery sizes available on each Sunrise Medical product should give sufficient range to cope with the majority of customer's lifestyles.

6.4 Battery warranty:

Battery warranties are subject to periods set by the manufacturers. However, most of these warranties are subject to a wear and tear clause, and if you genuinely wear out your batteries in 6 months, it will not be possible to obtain a replacement under warranty.

6.5 Replacing batteries

The wheelchair uses two 12V non-spillable AGM batteries in series, these batteries are fully sealed and require no maintenance.

Replacing and servicing batteries is to be done by qualified specialist.

In case of malfunctioning batteries, contact your local dealer.

Qualified specialist instruction:

- Disconnect the batteries as described in Section 6.6 below
- Remove the first battery
- Slide the second battery forward and then remove

DANGER!

- Do not attempt to replace or service batteries without the supervision of trained and qualified personnel.

6.6 Disconnecting batteries for air transport.

The batteries are contained within the drive unit located under the battery shroud.

To disconnect the batteries on Mid-wheel drive:

- Release the two handle screws under the front of the seat frame, that connect the seat frame with the seat module interface, (Fig.6.2).
- Flip the seat frame backwards (Fig.6.3).
- Ensure the seat is secured with the seat stay in place, before letting go, (Fig.6.4 - A). You must make sure that the red seat stay is fully latched onto the pin.
- Lift off the battery box lid, (Fig. 6.4 - B).
- Disconnect the 2 pin Anderson connectors from each battery (Fig.6.5).

To reconnect the batteries reverse the above procedure.

Fig. 6.2

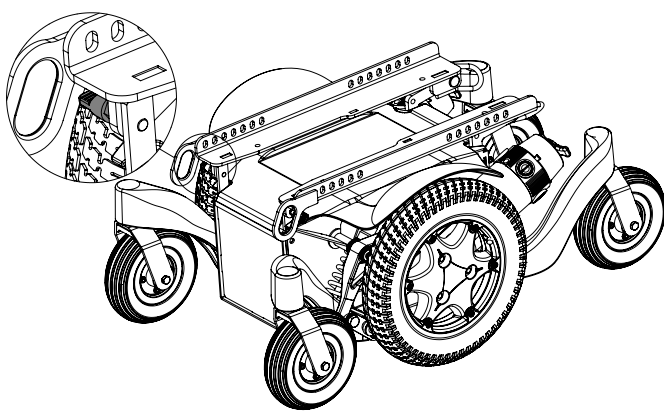

Fig. 6.3

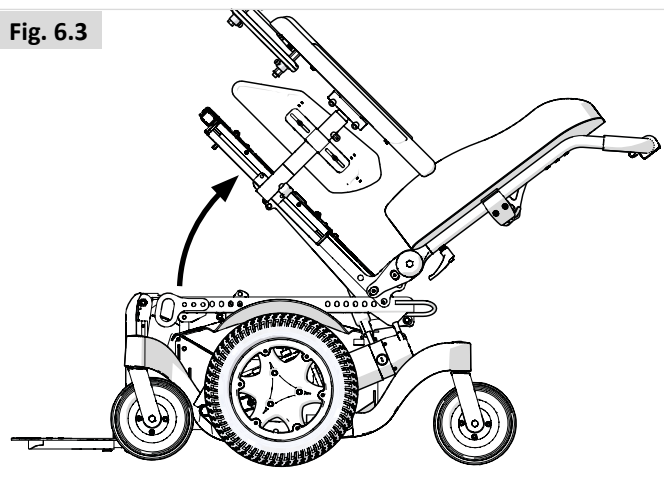

Fig. 6.4

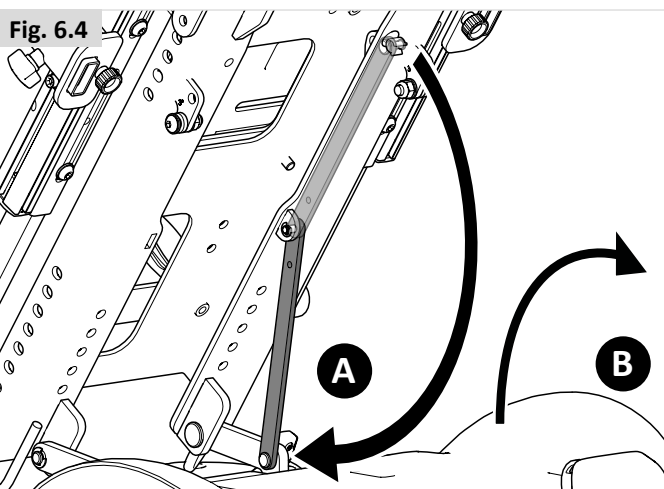
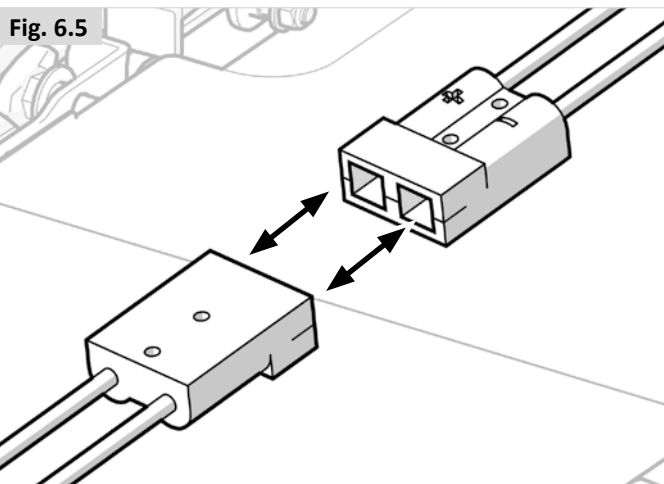

Fig. 6.5



7.0 Transportation

7.1 Transport of the wheelchair in a car

Getting in and out of the vehicle

! DANGER!

- Confirm that the vehicle is suitably equipped to transport a passenger in a wheelchair, and ensure the method of access/ egress is suitable for your wheelchair type. The vehicle should have the floor strength to take the combined weight of the occupant, the wheelchair and accessories.
- Use a ramp (or lifting device) suitable for the entire weight of the wheelchair (including user) for entering the vehicle.
- The wheelchair should be secured in a forward facing direction. This wheelchair is approved for use in cars and meets the requirements for forward facing transport and head on collisions. The wheelchair has not been tested for other positions in a vehicle (Fig. 7.1).

! CAUTION!

- Sufficient space should be available around the wheelchair to enable clear access to attach, tighten and release the wheelchair and occupant tie down restraints and safety belts.
- Ease of access to, and manoeuvrability in, motor vehicles can be significantly affected by wheelchair size and turning radius; smaller wheelchairs and/ or wheelchairs with a shorter turning radius will generally provide greater ease of vehicle access and manoeuvrability to a forward-facing position.

Securing the wheelchair with a strap restraint system

This wheelchair has been successfully crash tested in accordance to: ISO 7176-19:2008, using a representing restraint system.

- Use 6 straps if the 4-point system is not rated to the weight of the wheelchair (2 at the front and 4 at the back) that conforms to ISO 10542-1 (international). Standard straps are only tested to 85kg.
- It is recommended to use with a 4-point strap restraint system rated for the total weight of the wheelchair including any options (Heavy Duty System) - 2 at the front, 2 at the back that conforms to ISO 10542-1 (international).

NOTE: Use WTORS in accordance with the WTORS#1 manufacturers instruction.

Terminology explained:

- 1) *WTORS: Wheelchair Tie-down Occupant Restraint System*
Recommended angles for Tie-Down straps (Fig. 7.2 - 7.3).

Fig. 7.1

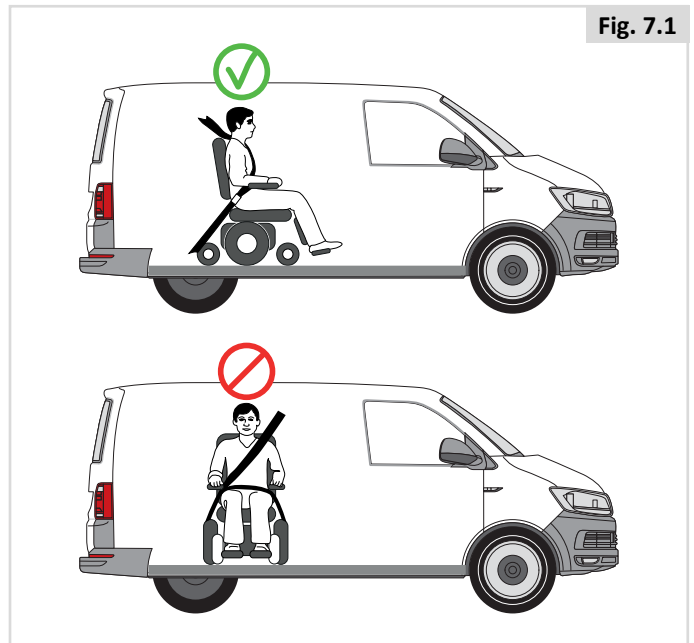
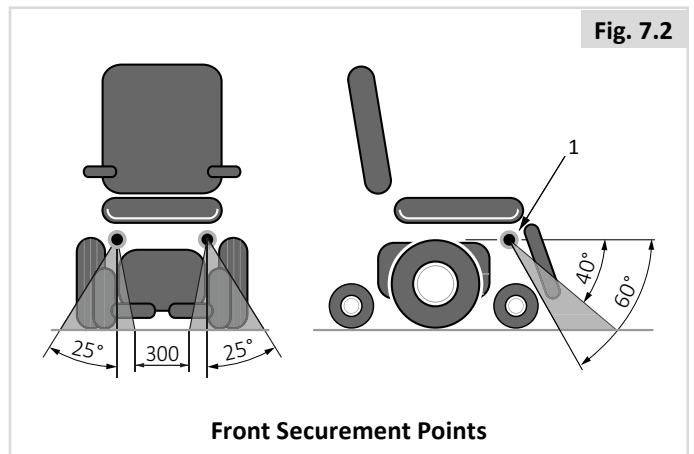
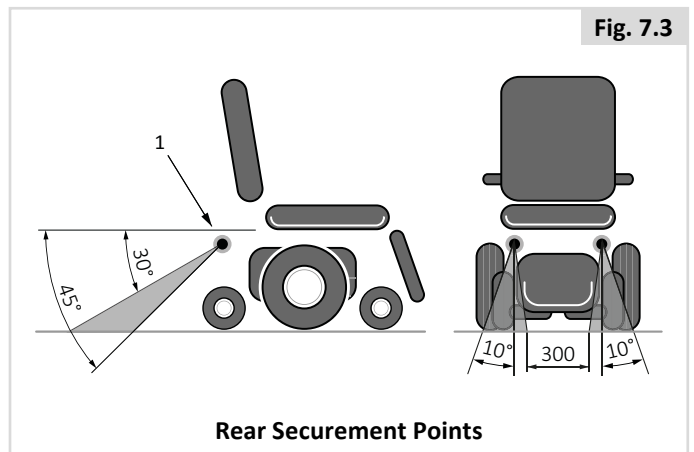

Fig. 7.2



Front Securement Points

Fig. 7.3



Rear Securement Points

⚠ DANGER!

- The wheelchair can only be secured by using the tie-down points on the wheelchair's frame (Fig. 7.5).
- The tie-down points (2 in the front, 2 in the back) are indicated by the tie-down symbol (Fig. 7.4). Fit the front straps first, then the rear. Tension the straps to secure the wheelchair. The wheelchair may not be secured onto any accessories (wishbones, armrests, anti-tip brackets etc.).
- No changes or replacements must be made to the anchorage points/car fastenings on the wheelchair, or to constructional elements or parts of the frame without consulting the manufacturer.
- When the wheelchair is transported in a vehicle without occupant and no restraint system is available then the wheelchair should be properly stored and secured in the cargo area during travel.

Fig. 7.4

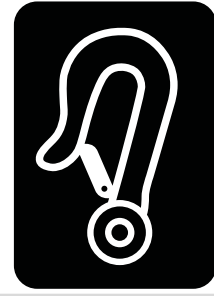
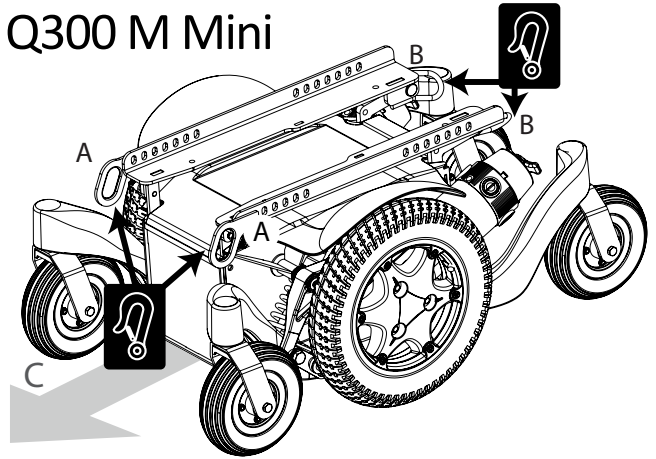

Fig. 7.5

Q300 M Mini



- A** Front Tie Down Points.
- B** Rear Tie Down Points.
- C** Direction of Travel.

7.2 Using the Dahl Docking System

CAUTION!

The installation should be performed or supervised by a technician. Read all instructions carefully before proceeding with the installation.

To install Docking Plate use Dahl Adaption Kit #500094

1. Fit the 8 mm spacer onto the lock plate (Fig. 7.6).
2. Use more spacers to achieve desired thickness with regards to, for instance, user weight and tire pressure.
Additional spacers can be mounted under the locking station (Fig. 7.7). To align the height of the lock plate under wheelchair with the docking station fit spacers between the docking station and the vehicle floor to raise the docking station.

3. Put the five screws through the lock plate, the mandatory 8 mm spacer and the selected optional spacers (gray in picture) (Fig. 7.8).

WARNING!

Do not use any other screws than those supplied from Dahl engineering (Part #502800 which is Quality 14.9 with Torx Key Size 27). Standard screws will not be strong enough in the event of a collision.

4. Mount the five screws together with the spacer/spacers and the lock plate on the underside of the chassis box (Fig. 7.9).

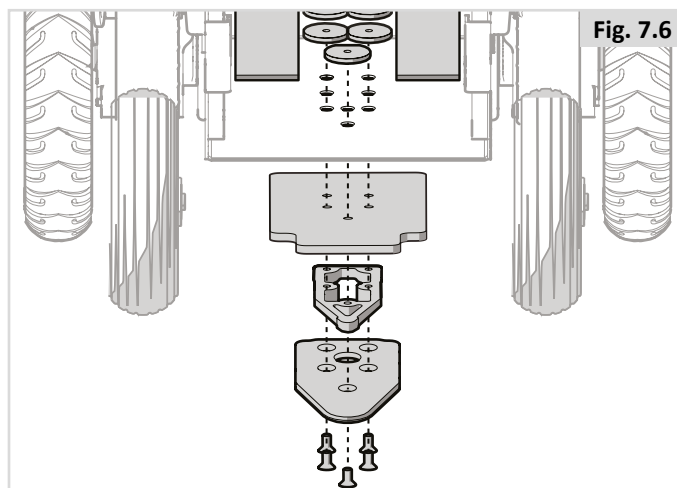

Fig. 7.6

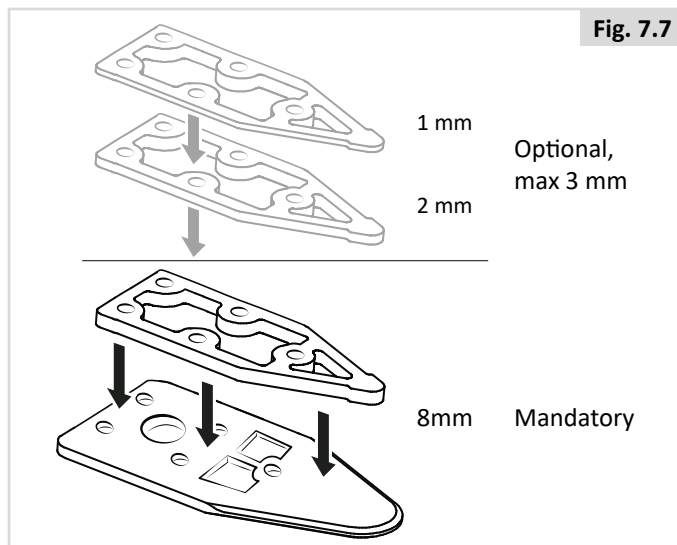

Fig. 7.7

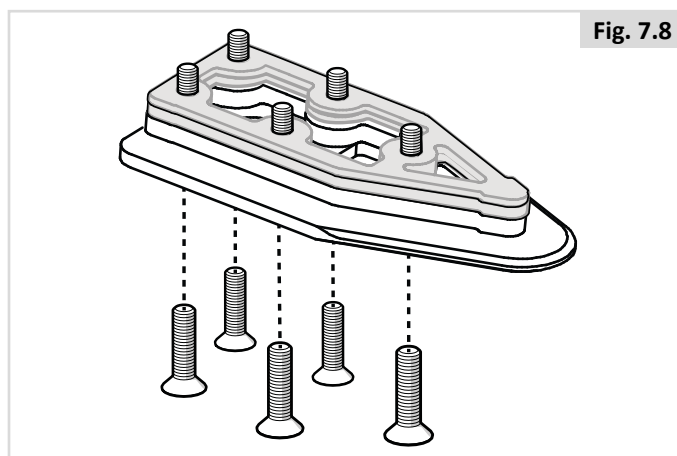

Fig. 7.8

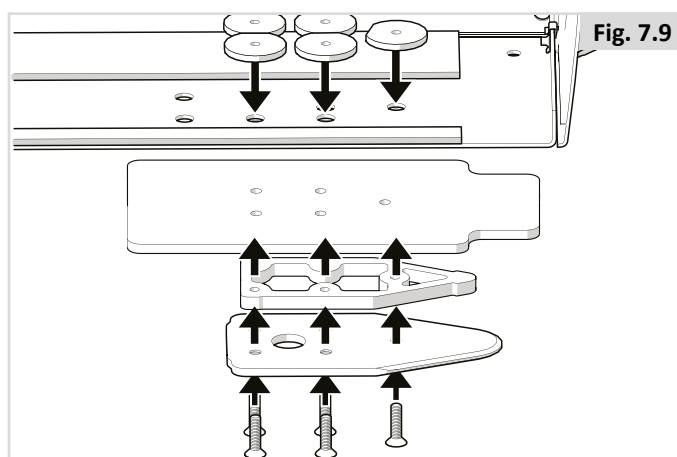
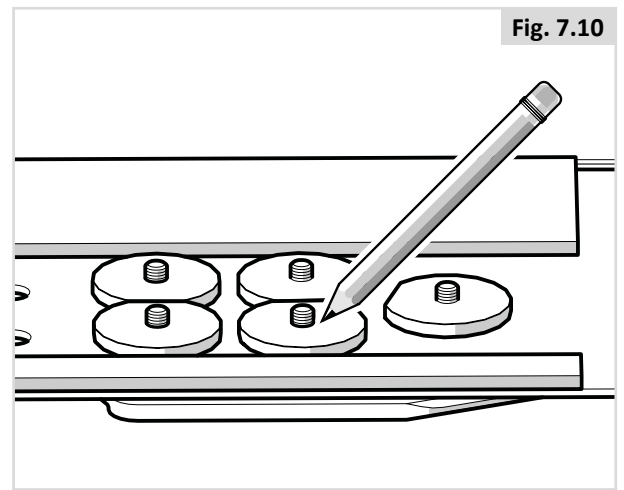
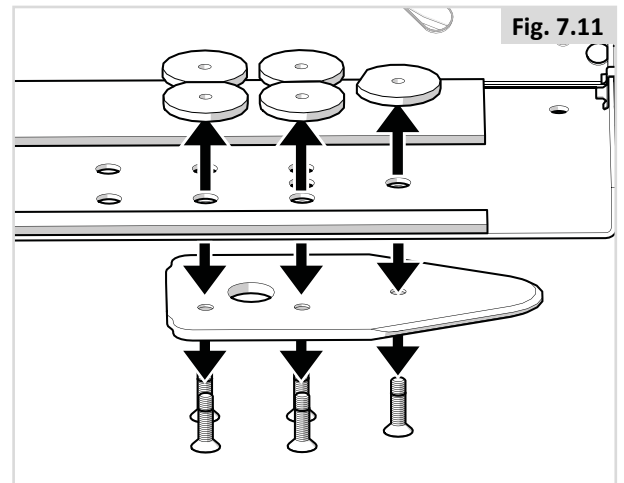

Fig. 7.9

5. Mark where to cut the screws. (Fig. 7.10).



6. Remove the screws together with the spacer/spacers (Fig. 7.11).



7. Cut the screw where the mark is (Fig. 7.12).

It is very important that the fitter checks that the length of the bolts are correct. If bolts are too short to reach through all the threads - they will not have the strength to carry the loads required. If bolts are too long the batteries or other wheel chair components can be damaged. If necessary replace with longer bolts, or shorten them.

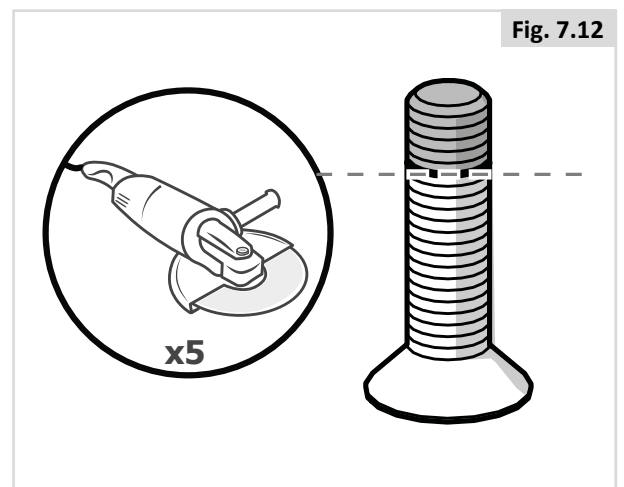

8. Apply Loctite 222 (or an equivalent product) onto the screw (Fig. 7.13).

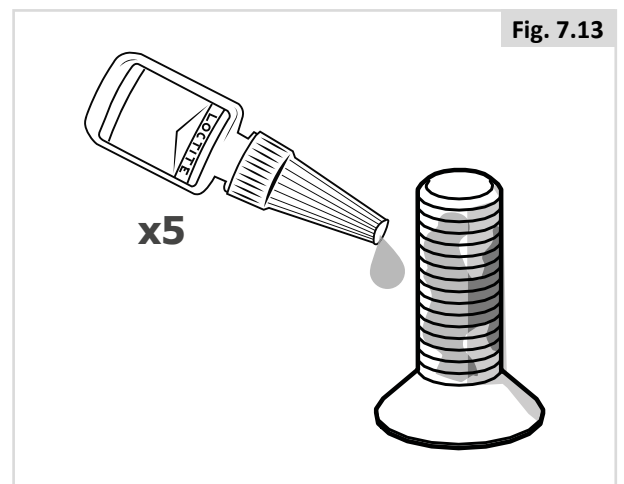

- Attach the five screws together with the plastic spacer/ spacers (to prevent the batteries from coming into contact with the nuts) and the lock plate on the underside of the chassis box. Tightening torque: 16-18 Nm/13.3 lb.ft (Fig. 7.14).

Please refer to Section 6.6 of this manual for reverse the procedure to replace batteries.

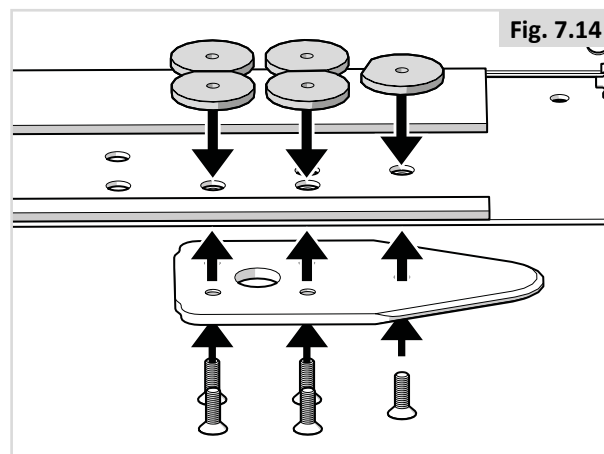

- Perform final check by connecting the wheelchair to the docking station. Check that it is securely locked and make sure that all release methods work as intended (Fig. 7.15).

A warning tone will sound if the lock plate is not properly engaged.

- (A) Release button.
- (B) Manual operating lever.
- (C) Emergency release.
- (D) Red LED.
- (E) Green LED.
- (F) Lock Plate.
- (G) Lock Pin.

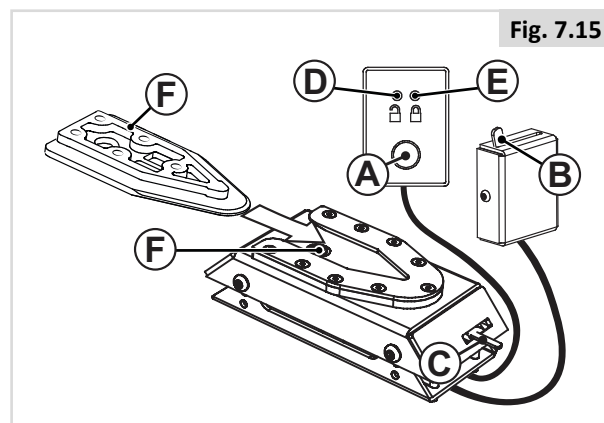

Securing the wheelchair in the docking station:

Make sure that the leg rests are not colliding with the ramp or the docking station when entering the vehicle.

- Manoeuvre the wheelchair slowly and in a uniform direction over the docking station. The lock plate under the wheelchair helps to guide the wheelchair into place in the docking station. When the lock plate is fully engaged in the docking station, a spring-action locking pin automatically secures the lock plate.
- The docking station is equipped with a control switch that indicates whether the lock plate is correctly secured in the docking station. As soon as the lock plate comes into contact with the locking pin, a warning tone will sound (a high-pitched howl), and the red diode/lamp (LED) in the control panel will light up until the lock plate is either fully engaged or else the wheelchair is removed from the docking station.
- As an indication that the wheelchair is properly secured, the warning tone will cease, the red diode in the control panel will go out and the green diode lamp (LED) will light up.
- Do not forget to buckle up for driving.

Release from the docking station

- When the vehicle has been brought to a halt, remove the safety belt.
- To unlock commence by driving the wheelchair forward to release pressure on the lock pin and then press the red release button in the control panel. The locking pin will be triggered/ released for approx. 5 seconds, after which the locking pin is automatically locked/activated again. Do not attempt to reverse out of the docking station until the red LED on the control module, which indicates the unlock position, has been illuminated.

WARNING! Attempting to reverse the wheelchair before the red LED has been illuminated will result in blocking the docking stations lock mechanism, which makes it impossible to reverse. If this happens repeat above unlocking procedure.

- Move the wheelchair away from the docking station within this 5-second period.

Manual release in case of electrical failure

- In the event of electrical failure, a manual emergency release is located at the front edge of the docking station. Move wheelchair forward to release pressure on the lock pin and push the red release arm to one side and hold it there while the wheelchair reverses out of the docking station.
- A cable-activated manual operating lever can also be fitted (accessory). The red release arm must pushed to one side and should be held there whilst the wheelchair moves away.
- If the described manual release procedures fails, an emergency release tool made from red plastic comes with each docking station.

Move wheelchair forward to release pressure on the lock pin and place the emergency release tool in the gap between the locking plate and the docking station. Push the release tool forward until the locking pin will has been forced down - after which the wheelchair can be reversed out of the docking station.

Please also refer to Dahl Engineering instructions for Installation, Use and Maintenance

7.3 The wheelchair as a passenger seat

A wheelchair secured in a vehicle will not provide the equivalent level of safety and security as a vehicle seating system. Sunrise Medical recommends that the user transfers to the vehicle seating and uses the vehicle-installed restraint system wherever possible. Sunrise Medical recognizes that it is not always practical for the user to be transferred and in these circumstances, where the user must be transported whilst in the wheelchair, the following advice must be followed:

⚠ DANGER!

- The safety of the user during transportation depends upon the diligence of the person securing the tie down restraints and they should have received appropriate instructions and/or training in their use.
- Wherever possible remove and stow safely away from the wheelchair all auxiliary equipment, e.g. : crutches, loose cushions, tray tables, etc.
 - i. Removed and secured separately in the vehicle, or
 - ii. Secured to the wheelchair, but with energy-absorbing padding placed between the table and the user.
- Articulating/elevating leg rest should not be used in the elevated position when the wheelchair and user are being transported.
- If applicable: Reclining backrests should be returned to an upright position.
- If applicable: Seat elevators should be in the lowest position.
- If applicable: The manual brakes must be firmly applied.

Occupant restraint Instruction

⚠ DANGER!

- Use a 3-point occupant restraint system to secure the occupant.
- Both pelvic and upper torso restraint belts must be used to restrain the occupant to reduce the possibility of head and chest impacts with the vehicle components.
- Restraints should be mounted to the appropriate vehicle pillar and should not be held away from the body by wheelchair components such as armrest or wheels (Fig. 7.16).
- Use a suitable positioned headrest when being transported in a wheelchair.
- Postural supports (lap straps, lap belts) should not be used or relied on for occupant restraint in a moving vehicle unless they are labelled as meeting the requirements specified in ISO 7176-19:2008 or SAE J2249.

Positioning the occupant restraint

⚠ DANGER!

- Belt restraints should make full contact with the shoulder, chest and pelvis and pelvic belts should be positioned low on the pelvis near the thigh-abdominal junction (meeting the requirements specified in ISO 7176-19:2008).
- The pelvic restraint belt must be worn low across the front of the pelvis so that the angle of the pelvic belt is within the preferred zone of 30° to 75° to the horizontal.
- A steeper (greater) angle within the preferred zone is desirable i.e. closer to, but never exceeding 75° degrees (Fig. 7.17).
 - i. The upper torso restraint belt must fit over the shoulder and across the chest as illustrated (Fig. 7.17). Restraint belts must be adjusted as tightly as possible consistent with user comfort.
- Restraint belt webbing must not be twisted when in use.
- Care should be taken when applying the occupant restraint to position the seatbelt buckle so that the release button will not be contacted by wheelchair components during a crash.

Fig. 7.16

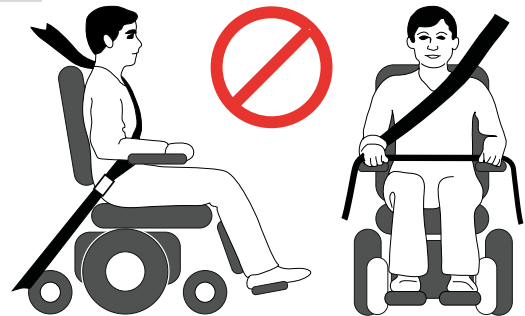
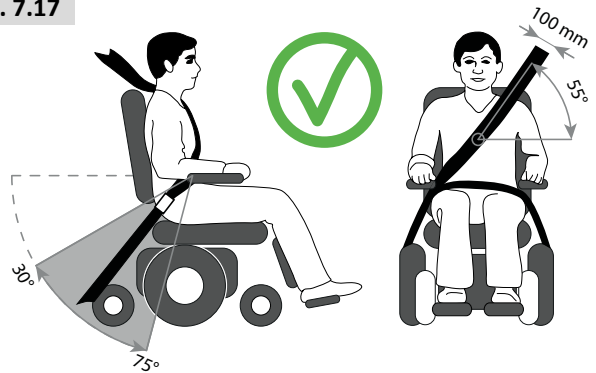

Fig. 7.17



Passenger with a user weight < 22 kg.

When the user being transported is a child, less than 22 kg mass and the vehicle involved has less than eight (8) seated passengers it is recommended that they be transferred to an UNCE Regulation 44 compliant child restraint system (CRS). This type of restraint system provides a more effective occupant restraint system than the conventional 3 point occupant restraint system and some CRS systems also include additional postural supports to assist in maintaining the position of the child when seated.

Parents or care providers may consider the option, in some circumstances, for their child is to remain in their wheelchair whilst in transport due to the level of posture control and comfort provided by the set up in the wheelchair.

We would recommend in such circumstances that a risk assessment be carried out by your healthcare professional and relevant competent persons.

7.4 Special transport requirements

Using your wheelchair on the train.

Before you travel, please contact the train operator. They will be able to supply details of any special requirements/ instructions. We advise you to check the following:

- Is there a suitable and intended “wheelchair” area in the train for wheelchair users (with adequate turning space to manoeuvre)?
- Is there a suitable or designated area on the platform for wheelchair users (with adequate turning space to manoeuvre)?
- Is there suitable boarding access available to allow you to access the railway carriage and the intended “wheelchair” area?
- Is the boarding access suitable for the combined mass of the wheelchair and the occupant?
- Make sure the slope of the boarding access is not greater than the dynamic safe slope. (See Section 10)
- Any obstacles or thresholds should not exceed the max kerb climbing capability of your wheelchair. (See Section 10)

Most train operators will provide assistance provided that arrangements have been made in advance. We suggest you have your Owner’s Manual ready when planning your journey and contacted them.

WARNING!

- The Gyro CANNOT be used on moving vehicles, such as buses, trains or boats. When travelling on moving vehicles the **GYRO MUST BE DISABLED** by selecting drive profile 1 on your controller.
- DO NOT remove the GYRO from your product. If the GYRO is disconnected the powerchair maximum speed will be limited by 50%.

Transporting the wheelchair as luggage.

Parts of the wheelchair that can easily be detached should be removed when transporting the wheelchair. Store these parts securely. e.g.:

- A. Remove the seat (📖 Seating system).
 - B. Remove the leg rests (📖 Seating system).
 - C. Remove the armrests (📖 Seating system).
 - D. Fold down the backrest (📖 Seating system).
- Ensure that any detachable parts are secured with your mobility aid or separately packed and labelled so they do not get lost during loading and unloading.
 - The wheelchair may be transported by road, rail, sea or air as the batteries supplied conform to IATA regulations. If the batteries are replaced by non-IATA approved batteries then they will need to be removed for air travel. Your dealer can assist in supplying batteries that are IATA approved.
 - Before you travel, please contact the appropriate carrier. The travel operator will be able to supply details of any special requirements/instructions.
 - For information about dimensions and weight of the wheelchair, see (Section 10).
 - For information about the batteries in your wheelchair see (Section 6).
 - Ensure that any detachable parts are secured with your mobility aid or separately packed and labelled so they do not get lost during loading and unloading.
 - Take this user manual, the seating system user manual (& Seating System) and the controller user manual (& Controller) with you. The carrier will need to refer to the following sections:
 - i. Pushing the wheelchair, (Section 5.8).
 - ii. How to lock/unlock the controller: 📖 Controller.
 - iii. How to disconnect the batteries, (Section 6.7)
 - iv. How to disconnect the drive, (Section 5.8)
 - Transporting the chair, (Section 7.0).
 - Medium to long term storage, follow the instructions, (Section 8.5).

7.5 Hoisting the wheelchair:

(Fig. 7.18)

The Q300 M Mini can be hoisted, unoccupied, by means of four suitably rated lifting straps.

Connect the straps to the wheelchair using the four tie-down brackets.

Refer to section 7.1 for details of the tie-down points.

Fig. 7.18



⚠ CAUTION!

Before you travel, please contact the appropriate carrier. The travel operator will be able to supply details of any special requirements/instructions.

7.6 General transport warnings

⚠ WARNING!

- No changes or replacements must be made to the anchorage points/car fastenings on the wheelchair, or to constructional elements or parts of the frame without consulting Sunrise Medical.
- The wheelchair should be inspected by a Sunrise Medical authorised dealer/service agent, before reuse following involvement in any type of vehicle collision.

8.0 Maintenance & cleaning

The wheelchair's lifespan is dependent on it being well maintained.

For information concerning specific settings, maintenance or repair work, please contact your authorized Sunrise dealer. Always be sure to mention the model, year of manufacture and identification number provided on the identification plate of the wheelchair when contacting your dealer.

CAUTION!

The wheelchair should be serviced by your authorized Sunrise dealer once a year or, in the case of intensive use, every six months. For a list of approved authorised dealers in your area please contact Sunrise Medical Service Centre. The contact details of your local Sunrise medical service centre can be found on the inside front cover of this booklet. National and International Website addresses are on the back cover.

8.1 Maintenance

WARNING!

- Loose fasteners should be re-tightened according to the installation instructions. Please refer (unless otherwise specified) to the general table below for needed Torques.

Torque Setting Guide	
M4	3.0 Nm
M5	5.9 Nm
M6	10 Nm
M8	25 Nm
M10	48 Nm
M12	84 Nm

Note: it will be necessary to use a torque wrench.

- Chest straps should be replaced at the first indication of damage and/or excessive wear.
- If a broken or loose component is found, discontinue use immediately and contact your authorised Sunrise Medical supplier for replacement.
- Check all Velcro fastening straps for correct adhesion when pressed together.
- Ensure that any contamination, such as fluff, hair, etc is removed from the Velcro straps. Such contamination may affect adhesion.

WARNING!

- If you are in any doubt about the performance requirements of your wheelchair contact your Sunrise Medical authorised dealer.
- After performing any maintenance or repairs on the wheelchair you must make sure that it is functioning correctly before it is used.
- All fasteners must be replaced like for like using the correct length, tensile strength and materials.
- When replacing self-locking nuts, or nuts/studs secured with a thread locking solution, ensure that a suitable thread locking solution is reapplied to the fastener.

Daily checks

Perform the daily check routine before driving as described in chapter 5.1

Weekly checks

Perform the weekly check routine before driving as described below.

Checking Parking brake:

This test should be carried out on a level floor with at least one meter clearance all around the chair.

- Switch on the control system.
- Check that the battery gauge remains on, or flashes slowly, after one second.
- Push the joystick slowly forwards until you hear the parking brakes operate.
- The chair may start to move.
- Immediately release the joystick. You must be able to hear each parking brake operate, (click), within a few seconds.
- Repeat the test a further 3 times, pushing the joystick slowly backwards, left and right.

Checking connectors & cables:

- Make sure that all connectors are securely mated.
- Check all cables are not loose and secured to the chair.
- Check the condition of all cables and connectors for damage.

Checking controller:

- Check the thin rubber gaiter or boot around the base of the joystick shaft for damage or splitting. Check visually only, do not handle the gaiter.
- Make sure that all components of the control system are securely mounted. Do not over-tighten any securing screws.

Checking controls:

- Switch on the hand control – Do the lights flash? This signifies that there is a fault in the electronic system. Refer to chapter 9 for basic troubleshooting
- Operate all of the electric options, including lights and indicators, (if fitted), to make sure that they work correctly.
- With the seating in an elevated position, drive the wheelchair to make sure that the 'creep' mode works which will slow the wheelchair.
- Drive the wheelchair in each of the drive profiles to make sure the wheelchair performs as it did before.

WARNING!

- If you are in any doubt about the performance requirements of your wheelchair contact your Sunrise Medical authorised dealer.
- After performing any maintenance or repairs on the wheelchair you must make sure that it is functioning correctly before it is used.
- A complete inspection, safety check and service should be made by a Sunrise Medical authorised dealer at least once per year.
- All fasteners must be replaced like for like using the correct length, tensile strength and materials.
- When replacing self-locking nuts, or nuts/studs secured with a thread locking solution, ensure that a suitable thread locking solution is reapplied to the fastener.
- Check all Velcro fastening straps for correct adhesion when pressed together.
- Ensure that any contamination, such as fluff, hair, etc is removed from the Velcro straps. Such contamination may affect adhesion.

Monthly checks

Perform the monthly check routine before driving as described below.

- All fasteners should be checked monthly for wear, such as loose bolts or broken components.
- Check all straps monthly for fraying, ripped seams or other indications of excessive wear damage. Discontinue use if damage is found.

8.2 Tyre maintenance and pressures

8.2.1 Tyre pressure

CAUTION!

If pneumatic tyres are fitted to your wheelchair it is important to regularly check the air pressure and for signs of wear. The maximum tyre pressures are listed in Section 8.3, if in doubt check the markings on the side of the wheelchair tyre for guidance.

NOTE: It is important that drive wheels are inflated to equal pressures as a pair, and likewise the rear. The inflator pump provides the safest method of inflating your wheelchair tyres and the pressure can be checked with a standard motor vehicle pressure gauge.

DANGER!

- Do not inflate beyond the maximum allowed tyre pressure.
- Always use the pump that is supplied with the chair,

8.2.2 Tyre wear

When inspecting the tyres for signs of wear, look for significant scuff marks, cuts and a diminished tyre tread. Tyres will need to be changed when the tread cannot be seen over the complete surface of the tyre, (Fig.8.1).



8.2.3 Drive wheel tyre repair

To remove the wheel/tyre:

Please see below and next page for photographs.

- Remove the colour ring.
- Use a 16mm AF socket to release 3 studs/lug nuts (Fig. 8.2).
- Jack the base/battery box up and support it using blocks, (Fig. 8.3).
- Remove the 3 studs and pull the wheel away from the hub.
- Remove the valve cap and let the air out of the tyre by gently pressing the valve stem with a small screw driver, (Fig. 8.4).
- There are 6 rim studs that must be loosened/tightened in the number order shown, (Fig.8.5).
- Use a 5.0 mm Allen key to release/tighten the studs. (Fig. 8.5).
- Lift the inner rim off the tyre wall (Fig. 8.6).
- Lift the tyre and tube off the outer rim, (Fig.8.7).
- Gently get a hold of the inner tube just behind the valve.
- Carefully feed the tube out of the tyre, (Fig.8.8).
- Ensure all parts are clean before reassembling, (Fig.8.9).

To refit

- Place the tube inside the tyre and rest the tyre on the outer rim.
- Align the valve stem with the cut out in the rim.
- Face the valve stem outward.
- Place the inner rim over the tyre, tube and outer rim.
- Align the cut out to fit over the valve stem and match it up to the cut out in the outer rim, (Fig.8.10).
- Make sure the stud mounts are in line on both rims.
- Tighten the studs in the sequence shown in Fig.8.5, taking care not to pinch the tube.
- Slowly inflate to the pressures quoted in section 8.3 .
- Refit the wheel back onto the motor shaft and fix it safely with the 3 studs to a torque of 34Nm.

For solid tyres the sequence is the same, just discount the references to the inner tube and valve.

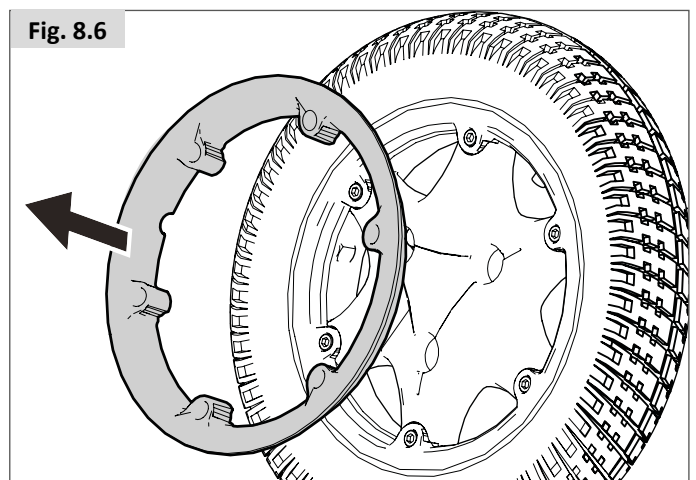
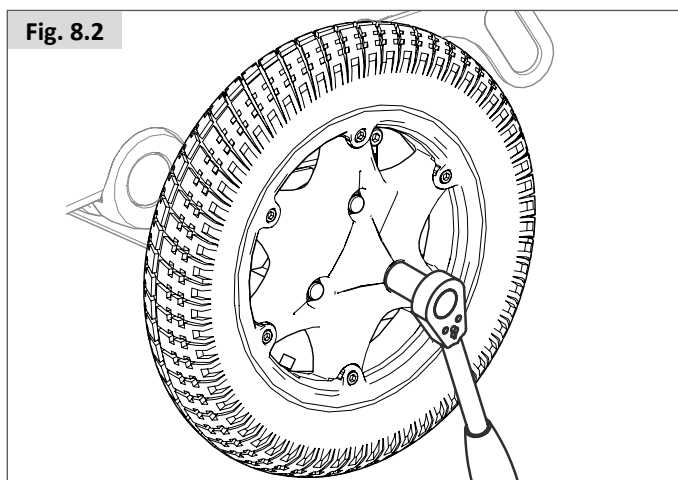
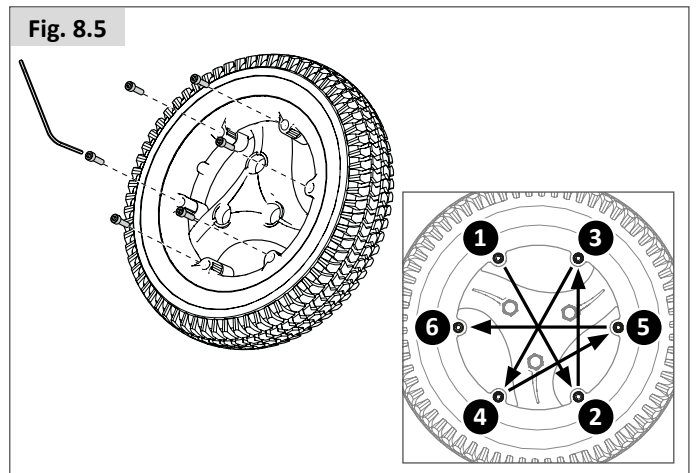
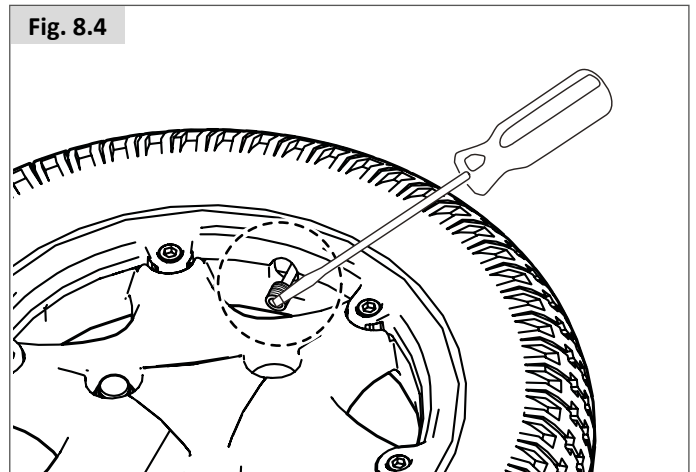
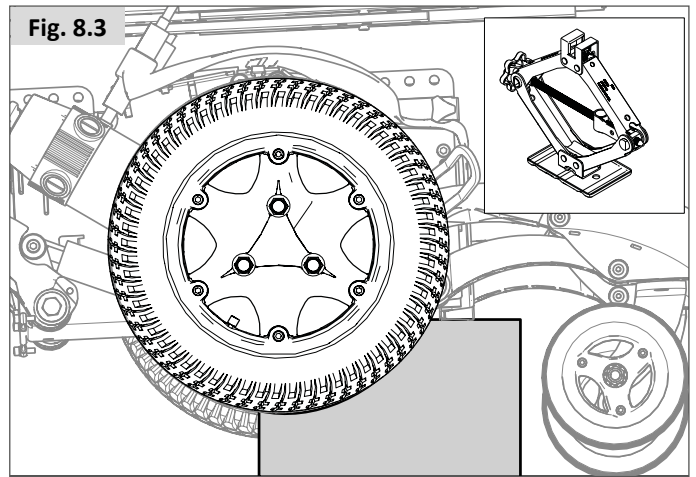

Fig. 8.7

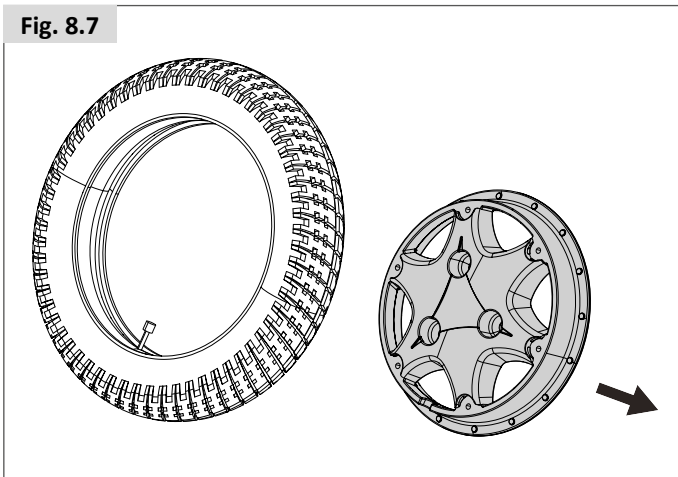

Fig. 8.8

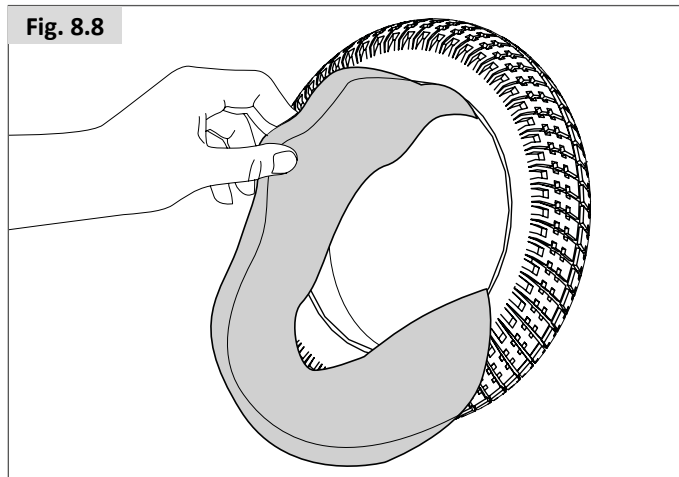

Fig. 8.9

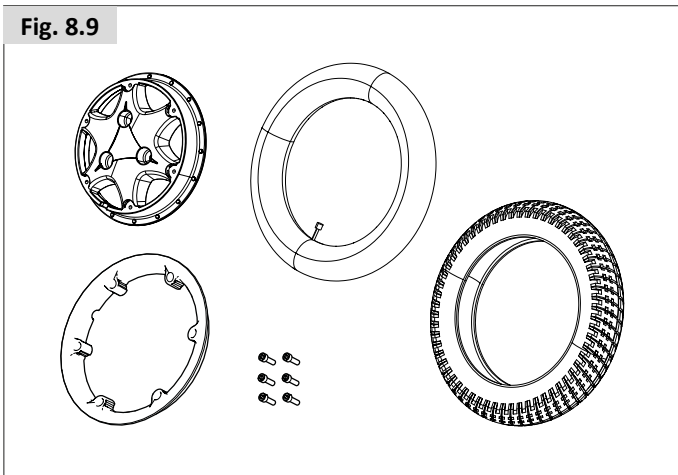
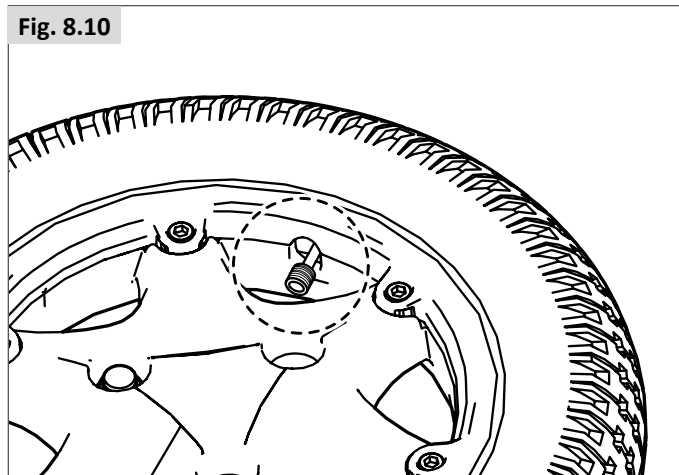

Fig. 8.10



8.2.4 Removing the castor wheels (M base) (Fig.8.11).

- Use two 13mm spanners/sockets to undo the axle bolt.
- Remove the nyloc nut.

Refitting:

When refitting do not try to force the bolt through. Gently move the wheel back and forth until the bolt slips through then tighten to a torque of 20Nm.

WARNING!

Always use a new nyloc nut when refitting.

Fig. 8.11

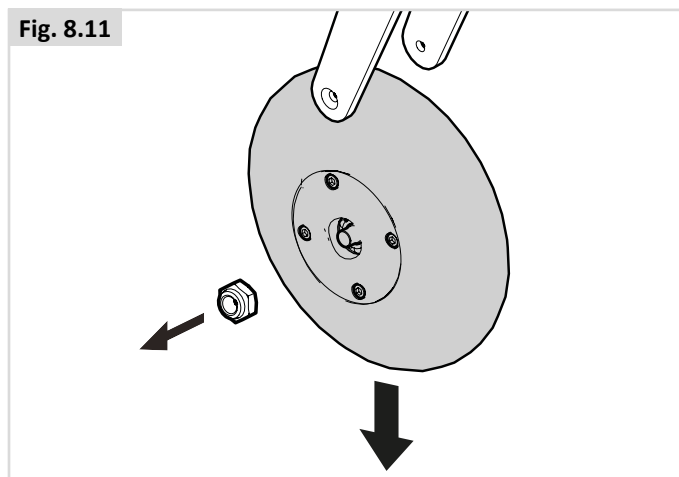

Maintenance & Inspection Schedule	Daily*	Weekly	Monthly	Annually
Daily check routine as described in chapter 5.1	*			
Weekly check routine as described in chapter 8.1		*		
Clean wheelchair upholstery  Seating system		*		
Complete inspection, safety check and service should be made by a Sunrise Medical authorised dealer.				*

8.3 Wheels & tyres maintenance

To ensure that your wheelchair functions properly, it is essential that the tires are kept at the correct pressure. The correct tyre pressure is indicated on the side of the tyre.

Tyres that are too soft will have a negative effect on the wheelchair's performance. Moving the wheelchair will require more energy, making more demands on the batteries. Furthermore, wear on under inflated tyres is increased

When inspecting the tyres for signs of wear, look for significant scuff marks, cuts and a diminished tyre tread. Tyres will need to be changed when the tread cannot be seen over the complete surface of the tyre.

Castor wheel	Max. tyre pressure	
7"	Solid tyre only	
Drive wheel	Max. tyre pressure	
12"	Solid tyre only	
13" (2.50-8)	2.4 bar max.	35 PSI max.
14" (3.00-8)	3.5 bar max.	50 PSI max.

DANGER!

- Do not inflate beyond the maximum allowed tyre pressure.
- Never use a forecourt pump
- Before tyres are repaired they must first be fully deflated!

8.4 Lighting maintenance:

DANGER!

Maintaining lights and indicators is a safety critical task. If your lights and indicator system shows a defect, please contact your Sunrise Medical Approved Dealer.

All lights and indicators are state of the art LED low energy, no maintenance units. There are no light bulbs used. The high intrinsic reliability of these units means that they are extremely unlikely to fail under normal usage. If a failure should occur, (may be as a result of an impact), the damaged light assembly must be replaced in its entirety. The individual LED's cannot be replaced.

CAUTION!

- We recommend the use of Sunrise Medical authorized spare parts only.
- Be advised that all lighting circuits are electronically protected. In the event of a short circuit current will be limited to a safe level. Once the fault is removed the system resets automatically.

8.5 Cleaning and disinfection

The wheelchair should be wiped over once per week with a slightly damp, not wet, cloth and any fluff or dust that has accumulated around the motors should be blown or dusted away.

CAUTION!

Make sure that you dry all parts of your wheelchair if it becomes wet or damp after cleaning or if it is used in a wet or damp atmosphere.

DANGER!

It is important that should the wheelchair be used by more than one person it is cleaned thoroughly to ensure there is no cross infection.

Hygiene measures when being re-used:

Prior to the wheelchair being re-used, it must be carefully prepared. All surfaces which come into contact with the user must be treated with a disinfection spray.

To do this, you must use a disinfectant as authorised/recommended in your country, for rapid alcohol-based disinfection for medical products and medical devices, which must be disinfected quickly.

Please be aware of the manufacturer's instructions for the disinfectant you are using.

In general, a complete disinfection cannot be guaranteed on seams. We therefore recommend that you dispose of seat and back slings to avoid micro-bacterial contamination with active agents according to your local infection protection law.

CAUTION!

- Do not use solvents, bleaches, abrasives, synthetic detergents, wax polishes or aerosols.
- Disinfectants may be used in dilution as specified by their manufacturer.
- Ensure surfaces are rinsed with clean water and dried thoroughly.

WARNING!

- Always read the label on any commercial or domestic cleaning substances.
- Always follow the instructions carefully.

Cleaning controls:  Controller

Should the control of your wheelchair become soiled or dirty, it can be wiped with a damp cloth with a dilute disinfectant until clean.

DANGER!

Important: If the wheelchair is to be used by more than one person, follow the cleaning and disinfection instructions carefully to ensure that there is no cross infection.

8.6 Medium to long term storage:

When storing your wheelchair for long periods of time (in excess of one week), follow these simple instructions:

- Fully charge the wheelchair for at least 24 hours.
- Disconnect the charger.
- Disconnect the batteries.

WARNING!

Never store your wheelchair:

- Outside.
- In direct sunlight, (plastic parts may discolour).
- Near a source of direct heat.
- In a damp environment.
- In a cold environment.
- With the batteries/battery boxes connected, (even if the controller is switched off).

Avoiding all of the above will minimise battery deep cycle discharge and extend battery lifetime.

When returning the wheelchair to use, please reconnect the batteries/battery boxes and charge the wheelchair for at least 24 hours before use.

Storage Temperature: Min: -40°C Max: 65°C
No restrictions on humidity and air pressure.

9.0 Disposal

The symbols below mean that in accordance with local laws and regulations your product should be disposed of separately from household waste. When this product reaches the end of its life, take it to the local collection point designated by local authorities. The separate collection and recycling of your product at the time of disposal will help conserve natural resources and ensure that it is recycled in a manner that protects the environment.

Ensure you are the legal owner of the product prior to arranging for the product disposal in accordance with the above recommendations and national requirements.

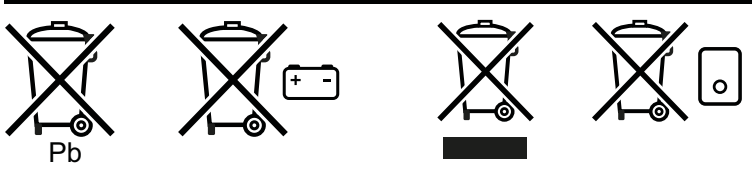

In the following section, there is a description of the materials used on the wheelchair, in view of the disposal or recycling of the wheelchair and its packaging.

For disposal or recycling of Seating System please see Sedeo Lite or Sedeo Pro manual ( Seating system).

There may also be special local regulations in force with regard to disposal or recycling, these must be taken into account when disposing of your wheelchair. (This can include the cleaning or decontamination of the wheelchair prior to disposal).

Aluminium: Castor forks, wheels, side-guards for the chassis.

Steel: Fixing points, quick-release axle

Plastic: Handles, tube stoppers, castors and wheel/tyre

Packaging: Plastic bags made of soft polyethylene, cardboard

Disposal or recycling should be done through a licensed agent or authorised place of disposal. Alternatively your wheelchair may be returned to your dealer for disposal.



10.0 Trouble shooting

If the wheelchair is not working as it should, check the following points.

- Check whether the batteries are charged.
- Turn the wheelchair off and then back on again.
- Check whether the battery plugs are all securely in place.
- Check whether the freewheel lever is in the DRIVE position
- Check the position of the speed regulator.
- Make sure that the controller isn't locked  Controller

If the problem has not been resolved:

-  Controller

11.0 Technical specifications: Applicable norms / standards



This product complies with the regulations and guidelines for medical aids and carries a CE symbol.

The product meets the requirements and standards below. These are checked by independent institutions.

EN ISO 10993-5:2009

Biological evaluation of medical devices - Part 5: Tests for in vitro cytotoxicity (ISO 10993-5:2009)

Standard	Definition / description	Test Dummy Weight	
Medical Device Regulation (EU) 2017/745	Applicable as mentioned in Appendix 1		
EN 12182: 2012 Class B	Assistive products for persons with disability - General requirements and test methods	SEDEO Lite / Pro	QUICKIE Teens / ZIPPPIE Kids
	Q300 M Mini	136 kg	120kg / 75kg
EN 12184: 2014 Class B	Electrically powered wheelchairs, scooters and their chargers - Requirements and test methods	SEDEO Lite / Pro	QUICKIE Teens / ZIPPPIE Kids
	Q300 M Mini	136 kg	120kg / 75kg
ISO 7176-19: 2008	Wheelchairs - Part 19: Wheeled mobility devices for use as seats in motor vehicles: The Q-series meet the crash test requirements as described in ISO 7176-19	SEDEO Lite / Pro	QUICKIE Teens / ZIPPPIE Kids
	Q300 M Mini	78 kg	78kg

Model	Q300 series	
Type / configuration Mid wheel drive	Q300 M Mini	
Maximum user weight		
In combination with Sedeo Lite	136 kg	300 lbs.
In combination with Sedeo Pro	136 kg	300 lbs.
EN12184 class:	B	

Description	Metric system values		Imperial system values & alternative	
	Minimum	Maximum	Minimum	Maximum
Total length (including legrests) Mid wheel drive				
Sedeo Lite Central footplate	1060 mm	1100 mm	41.7"	43.3"
Sedeo Lite Manual / power ELR	1180 mm	1440 mm	46.5"	56.7"
Sedeo Pro Power centre mount	1144 mm	1266 mm	45.0"	49.8"
Sedeo Pro Power elevating	1200 mm	1354 mm	47.2"	53.3"
Sedeo Pro Swing away	1122 mm	1275 mm	44.2"	50.2"
Total width Drive wheel type dependant	520 mm	570 mm	20.5"	22.4"
Total weight Basic configuration, no batteries	80 kg		176 lbs.	
Total weight influencers Batteries				
41 Ah AGM (C20) (Set of 2)	+ 23 kg		+ 50.6 lbs.	
56 Ah AGM (C20) (Set of 2)	+ 30 kg		+ 66 lbs.	
Transport weight of the heaviest part	24.2 kg		53.3 lbs.	
Dynamic stability: Rated slope	8°		14 %	
Min. braking distance at maximum speed	1000 mm	2100 mm	39.4"	87.2"
Static stability				
Q300 M Mini Sedeo Lite Downwards / Upwards / Sideways	9°/9°/9°	13°/15°/13°	15,8%/15,8%/15,8%	23%/26%/23%
Q300 M Mini Sedeo Pro Downwards / Upwards / Sideways	9°/9°/9°	13°/15°/13°	15,8%/15,8%/15,8%	23%/26%/23%
<i>NB: The following aspects have a negative influence on the range of action: Obstacles, rugged terrain, driving on slopes, exposure to temperatures below freezing point and frequent use of powered seat options.</i>				
6 kph	27 km	36 km	16.9 miles	22.5 miles
8 kph	25 km	33 km	15.6 miles	20.6 miles
10 kph	26.7 km	35.6 km	16.7 miles	22.3 miles
Climbing capability for obstacles Mid wheel drive	70 mm		2.8"	
Max speed forward Mid wheel drive	6 kph	10 kph	4 mph	6.2 mph
Turning radius Centre mount footrest	560 mm		22.0"	
Turning space / reversing width Mid wheel drive	1100 mm		43.0"	
Ground clearance Mid wheel drive	45 mm		1.8"	

Description	Metric system values		Imperial system values & alternative	
	Minimum	Maximum	Minimum	Maximum
Maximum battery dimensions (l x b x h)	195 x 165 x 174 mm		7.7 x 6.5 x 6.9"	
Battery capacity	41 Ah / 56 Ah		41 Ah / 56 Ah	
Maximum permissible charging voltage	24V		24V	
Maximum charging current	10 A (rms)		10 A (rms)	
Connector type	📖 Controller manual		📖 Controller manual	
Insulation	Class 2 double insulated		Class 2 double insulated	

Technical specifications: SEDEO Lite seating system

	Metric system values		Imperial system values & alternative	
	Minimum	Maximum	Minimum	Maximum
Seat angle adjustment				
Powered tilt with COG adjustment optional	0° - 30°		-5° - 25°	
Powered tilt with COG adjustment optional	-5° - 25°		0° - 30°	
Powered tilt with COG adjustment optional	0° - 50°		0° - 50°	
Effective seat depth	410 mm	560 mm	16.1"	22.0"
Effective seat width	385 mm	510 mm	15.2"	20.1"
Seat to floor height				
Filler Module (No powered tilt in space, no seat elevator)				
pos. 1 0° seat angle	410 mm		16.1"	
pos. 2 0° seat angle	430 mm		16.9"	
pos. 3 0° seat angle	450 mm		17.7"	
pos. 4 0° seat angle	470 mm		18.5"	
Powered tilt & seat elevator (300 mm)				
pos. 1 0° seat angle	430 mm	730 mm	16.9"	28.7"
pos. 2 0° seat angle	450 mm	755 mm	17.7"	29.5"
pos. 3 0° seat angle	470 mm	770 mm	18.5"	30.3"
Powered tilt & seat elevator (300 mm) with Powered backrest recline				
pos. 1 0° seat angle	450 mm	755 mm	17.7"	29.5"
pos. 2 0° seat angle	470 mm	770 mm	18.5"	30.3"
pos. 3 0° seat angle	490 mm	790 mm	19.3"	31.1"
Backrest angle				
Tool angle adjustable back	86°,90°,94°,98°,102°,106°		86°,90°,94°,98°,102°,106°	
Powered recline	85° - 120°		85° - 120°	
Backrest height (seatplate to top of back cushion)	460 mm	510 mm	18.1"	20.1"
Flip back armrest				
Armrest pad height (seatplate to top armpad)	190 mm	320 mm	7.5"	12.6"
Armrest pad depth (on armrest profile)	100 mm		3.9"	
Armrest pad angle (vertical)	0° - 15°		0° - 15°	
Single Post Flip back armrest				
Armrest pad height (seatplate to top armpad)	250 mm	400 mm	9.8"	15.7"
Armrest width (on seatframe)	-20 mm	+20mm	-0.79"	+0.79"
Armrest pad width (on armrest profile)	-20 mm		-0.79"	
Armrest depth (on seatframe)	250 mm		9.8"	
Armrest pad depth (on armrest profile)	140 mm		5.5"	
Armrest pad angle (vertical)	0° - 15°		0° - 15°	
Center Mount Legrest				
Lower leg length (from seatplate)	305 mm	460 mm	12"	18.1"
Knee angle	90°		0°	
Ankle angle	+20° - -20°		+20° - -20°	
Swing away SEDEO LITE legrests				
Lower leg length (from seatplate)	350 mm	510 mm	13.8"	20.1"
Knee angle	70°		70°	
Ankle angle	0° - 180°		0° - 180°	

	Metric system values		Imperial system values & alternative	
	Minimum	Maximum	Minimum	Maximum
Swing away SEDEO LITE legrests, manual elevating / power elevating				
Lower leg length (from seatplate)	350 mm	510 mm	13.8"	20.1"
Knee angle	0° - 70°		0° - 70°	
Ankle angle	0° - 180°		0° - 180°	
Swing away UNI legrests				
Lower leg length (from seatplate)	350 mm	510 mm	13.8"	20.1"
Knee angle	80°		80°	
Ankle angle	0° - 180°		0° - 180°	
Swing away SEDEO PRO legrests				
Lower leg length (from seatplate)	350 mm	510 mm	13.8"	20.1"
Knee angle	70°		70°	
Ankle angle	0° - 180°		0° - 180°	
Swing away SEDEO PRO legrests, manual elevating / power elevating				
Lower leg length (from seatplate)	350 mm	510 mm	13.8"	20.1"
Knee angle	0° - 70°		0° - 70°	
Ankle angle	0° - 180°		0° - 180°	
SEDEO Multi-Position headrest mount				
Headrest height adjustment range	170 mm		6.7"	
Headrest depth adjustment range	200 mm		7.9"	
Headrest angle (vertical)	-45° - +45°		-45° - +45°	
Headrest width	-20 mm	20 mm	-0.8"	+0.8"
Lateral Supports				
Lateral support width adjustment range	90 mm		3.5"	
Lateral support height adjustment range	170 mm		6.7"	
Lateral support depth adjustment range	45 mm		1.8"	
Pommel				
Pommel height (from seatplate to top of cushion)	170 mm	250 mm	6.7"	9.8"
Pommel depth adjustment range	65 mm		2.5"	

Technical specifications: SEDEO Pro seating system

	Metric system values		Imperial system values & alternative	
	Minimum	Maximum	Minimum	Maximum
Seat angle adjustment				
Powered tilt with COG adjustment optional	0° - 30°		-5° - 25°	
Powered tilt with COG adjustment optional	-5° - 25°		0° - 30°	
Powered tilt with COG adjustment optional	0° - 50°		0° - 50°	
Effective seat depth	400 mm	560 mm	15.7"	22.0"
Effective seat width	385 mm	560 mm	15.2"	22.0"
Seat to floor height				
Filler Module (No powered tilt in space, no seat elevator)				
pos. 1 0° seat angle	410 mm		16.1"	
pos. 2 0° seat angle	430 mm		16.9"	
pos. 3 0° seat angle	450 mm		17.7"	
pos. 4 0° seat angle	470 mm		18.5"	
pos. 5 0° seat angle	490 mm		19.3"	
Powered tilt & seat elevator (300 mm)				
pos. 1 0° seat angle	430 mm	730 mm	16.9"	28.7"
pos. 2 0° seat angle	450 mm	750 mm	17.7"	29.5"
pos. 3 0° seat angle	470 mm	770 mm	18.5"	30.3"
pos. 4 0° seat angle	490 mm	790 mm	19.3"	31.1"
Backrest angle				
Tool angle adjustable back	86°,90°,94°,98°,102°,106°		86°,90°,94°,98°,102°,106°	
Powered recline	85° - 120°		85° - 120°	
Backrest height (seatplate to top of back cushion)	460 mm	510 mm	18.1"	20.1"
Flip back armrest				
Armrest pad height (seatplate to top armpad)	190 mm	320 mm	7.5"	12.6"
Armrest pad depth (on armrest profile)	100 mm		3.9"	
Armrest pad angle (vertical)	0° - 15°		0° - 15°	
Single Post Flip back armrest				
Armrest pad height (seatplate to top armpad)	250 mm	400 mm	9.8"	15.7"
Armrest width (on seatframe)	-20 mm	+20mm	-0.79"	+0.79"
Armrest pad width (on armrest profile)	-20 mm		-0.79"	
Armrest depth (on seatframe)	250 mm		9.8"	
Armrest pad depth (on armrest profile)	140 mm		5.5"	
Armrest pad angle (vertical)	0° - 15°		0° - 15°	
Center Mount Legrest				
Lower leg length (from seatplate)	305 mm	460 mm	12"	18.1"
Knee angle	90°		0°	
Ankle angle	+20° - -20°		+20° - -20°	
Swing away SEDEO LITE legrests				
Lower leg length (from seatplate)	350 mm	510 mm	13.8"	20.1"
Knee angle	70°		70°	
Ankle angle	0° - 180°		0° - 180°	
Swing away SEDEO LITE legrests, manual elevating / power elevating				
Lower leg length (from seatplate)	350 mm	510 mm	13.8"	20.1"
Knee angle	0° - 70°		0° - 70°	
Ankle angle	0° - 180°		0° - 180°	

	Metric system values		Imperial system values & alternative	
	Minimum	Maximum	Minimum	Maximum
Swing away UNI legrests				
Lower leg length (from seatplate)	350 mm	510 mm	13.8"	20.1"
Knee angle	80°		80°	
Ankle angle	0° - 180°		0° - 180°	
Swing away SEDEO PRO legrests				
Lower leg length (from seatplate)	350 mm	510 mm	13.8"	20.1"
Knee angle	70°		70°	
Ankle angle	0° - 180°		0° - 180°	
Swing away SEDEO PRO legrests, manual elevating / power elevating				
Lower leg length (from seatplate)	350 mm	510 mm	13.8"	20.1"
Knee angle	0° - 70°		0° - 70°	
Ankle angle	0° - 180°		0° - 180°	
SEDEO Multi-Position headrest mount				
Headrest height adjustment range	170 mm		6.7"	
Headrest depth adjustment range	200 mm		7.9"	
Headrest angle (vertical)	-45° - +45°		-45° - +45°	
Headrest width	-20 mm	20 mm	-0.8"	+0.8"
Lateral Supports				
Lateral support width adjustment range	90 mm		3.5"	
Lateral support height adjustment range	170 mm		6.7"	
Lateral support depth adjustment range	45 mm		1.8"	
Pommel				
Pommel height (from seatplate to top of cushion)	170 mm	250 mm	6.7"	9.8"
Pommel depth adjustment range	65 mm		2.5"	

Technical specifications: Zippie/Teens seating system

	Metric system values		Imperial system values & alternative	
	Minimum	Maximum	Minimum	Maximum
Maximum user weight				
Zippie Kids	75kg		75kg	
Quickie Teens	120kg		120kg	
Seat angle adjustment				
Powered tilt with COG adjustment optional	0° - 30°		-5° - 25°	
Powered tilt with COG adjustment optional	-5° - 25°		0° - 30°	
Powered tilt with COG adjustment optional	0° - 50°		0° - 50°	
Effective seat depth (Zippie Kids)	260 mm	400 mm	10.2"	15.7"
Effective seat depth (Quickie Teens)	360 mm	500 mm	14.2"	19.7"
Effective seat width	280 mm	400 mm	11"	15.7"
Seat to floor height				
Filler Module (No powered tilt in space, no seat elevator)				
pos. 1 60 or 80 Ah batteries 0° seat angle	410 mm		16.1"	
pos. 2 60 or 80 Ah batteries 0° seat angle	430 mm		16.9"	
pos. 3 60 or 80 Ah batteries 0° seat angle	450 mm		17.7"	
pos. 4 60 or 80 Ah batteries 0° seat angle	470 mm		18.5"	
Powered tilt & seat elevator (300 mm)				
pos. 1 60 or 80 Ah batteries 0° seat angle	N/A	N/A	N/A	N/A
pos. 2 60 or 80 Ah batteries 0° seat angle	N/A	N/A	N/A	N/A
pos. 3 60 or 80 Ah batteries 0° seat angle	450 mm	750 mm	17.7"	29.5"
pos. 4 60 or 80 Ah batteries 0° seat angle	470 mm	770 mm	18.5"	30.3"
Backrest angle				
Tool angle adjustable back	86°,90°,94°,98°,102°,106°		86°,90°,94°,98°,102°,106°	
Powered recline	85° - 120°		85° - 120°	
Backrest height (seatplate to top of back cushion)	380 mm	530 mm	15.0"	20.9"
Flip back armrest				
Armrest pad height (seatplate to top armpad)	190 mm	350 mm	7.5"	13.8"
Armrest pad length adjustment	90 mm		3.5"	
Armrest pad angle (vertical)	0° - 15°		0° - 15°	
Centre Mount Legrest Zippie				
Lower leg length (from seatplate)	180 mm	280 mm	7.1"	11.0"
Knee angle	80°		80°	
Ankle angle	+7° - -10°		+7° - -10°	
Centre Mount Legrest Teens				
Lower leg length (from seatplate)	290 mm	470 mm	11.4"	18.5"
Knee angle	90°		90°	
Ankle angle	+7° - -10°		+7° - -10°	
Swing away LIFE legrests				
Lower leg length (from seatplate)	320 mm	430 mm	12.6"	16.9"
Knee angle	70/80°		70/80°	
Ankle angle	+20° - -20°		+20° - -20°	

	Metric system values		Imperial system values & alternative	
	Minimum	Maximum	Minimum	Maximum
Swing away LIFE high mount legrests				
Lower leg length (from seatplate)	160 mm	480 mm	6.3"	18.9"
Knee angle	60° - 90°		60° - 90°	
Ankle angle	+50° - -50°		+50° - -50°	
Swing away UNI legrests				
Lower leg length (from seatplate)	350 mm	480 mm	13.8"	18.9"
Knee angle	75°		75°	
Ankle angle	+30° - -30°		+30° - -30°	
Swing away Zippie legrests				
Lower leg length (from seatplate)	160 mm	270 mm	6.3"	10.6"
Knee angle	90°		90°	
Ankle angle	+50° - -50°		+50° - -50°	
Swing away Zippie legrests, manual elevating				
Lower leg length (from seatplate)	170 mm	270 mm	6.7"	10.6"
Knee angle	25° - 87°		25° - 87°	
Ankle angle	+50° - -50°		+50° - -50°	
Swing away Salsa legrests, manual elevating				
Lower leg length (from seatplate)	410mm	510mm	16.1"	20.1"
Knee angle	18° - 75°		18° - 75°	
Ankle angle	+50° - -50°		+50° - -50°	
SEDEO Multi-Position headrest mount				
Headrest height adjustment range	170 mm		6.7"	
Headrest depth adjustment range	200 mm		7.9"	
Headrest angle (vertical)	-45° - +45°		-45° - +45°	
Headrest width	-20 mm	20 mm	-0.8"	+0.8"
Lateral Supports				
Lateral support width adjustment range	90 mm		3.5"	
Lateral support height adjustment range	170 mm		6.7"	
Lateral support depth adjustment range	45 mm		1.8"	

12.0 Warranty

THIS GUARANTEE DOES NOT AFFECT YOUR LEGAL RIGHTS IN ANY WAY.

Sunrise Medical* provides a guarantee, as set out in the warranty conditions, for products to its customers covering the following.

Warranty conditions:

1. Should a part or parts of the product require repair or replacement as a result of a manufacturing and/or material fault within 24 months, then the affected part or parts will be repaired or replaced free of charge. The warranty will only cover manufacturing defects
2. To enforce the warranty, please contact the supplier of your wheelchair – e.g. the Sunrise Medical Approved dealership or Healthcare provider with the exact details of the nature of the difficulty. Should you be using the product outside the area covered by the Sunrise Medical customer service agent, repairs or replacement will be carried out by another agency as designated by the manufacturer. The product must be repaired by a Sunrise Medical designated Customer Service agent, (dealer).
3. For parts, which have been repaired or exchanged within the scope of this warranty, we provide a warranty in accordance with these warranty conditions for the remaining warranty period for the product in accordance with point 1.
4. For original spare parts which have been fitted at the customer's expense, these will have a 12 months guarantee, (following the fitting), in accordance with these warranty conditions.
5. Claims from this warranty shall not arise, if a repair or replacement of a product or a part is required for the following reasons:
 - a. Normal wear and tear, which include but is not limited to the following parts where fitted; batteries, armrest pads, upholstery, tyres, brakes shoes, ferrules, etc.
 - b. Any overloading of the product, please check the EC label for maximum user weight.
 - c. The product or part has not been maintained or serviced in accordance with the manufacturer's recommendations as shown in the user instructions and/or the service instructions.
 - d. Accessories have been used which are not specified as original accessories.
 - e. The product or part having been damaged by neglect, accident or improper use.
 - f. Changes/modifications have been made to the product or parts, which deviate from the manufacturer's specifications.
 - g. Repairs have been carried out, before our Customer Service has been informed of the circumstances.
6. This guarantee is subject to the law of the country in which the product was purchased from Sunrise Medical"
7. Life expectancy

We estimate a life expectancy of five years for this product, provided that:

 - It is used in strict accordance with the intended use as set out in this document.
 - All maintenance and service requirements are met.

The estimated life expectancy can be exceeded if the product is carefully used and properly maintained, provided that technical and scientific advances do not result in technical limitations.

The life expectancy can also be considerably reduced by extreme or incorrect usage.















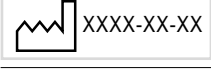

The fact that we estimate a life expectancy for this product does not constitute an additional warranty..

* Means the Sunrise Medical facility from which the product was purchased.

Additional Notes For Australia Only:

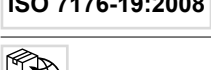
- i. For goods provided by Sunrise medical Pty Ltd in Australia, our goods come with a guarantee by Sunrise Medical that cannot be excluded under Australian Consumer Law.
- ii. You are entitled to a replacement or refund for a major failure and for compensation for any foreseeable loss or damage.
- iii. You are also entitled to have the goods repaired or replaced if the goods fail to be of acceptable quality and the failure does not amount to a major failure.
- iv. The benefits to you given by this warranty are in addition to your other rights and remedies under a law in relation to the goods to which the warranty relates.

13.0 Nameplate

TYPE:	Product Name/SKU Number.
	Maximum safe slope with anti-tip tubes fitted, Depends on wheelchair setting, posture and physical capabilities of the user.
	Maximum user weight.
	Load Maximum.
	Maximum speed.
	Maximum axle loading.
	UKCA Mark.
	CE Mark.
	Consult instructions for use.
	Indicates electrical / electronic equipment must be disposed of in accordance with the WEEE regulation.
	Date of manufacture.
	Serial number.
	This symbol means Medical Device.
	Manufacturer's address.
	Crash tested according to ISO 7176-19:2008.
	Importer's address
	UK Responsible Person
	Swiss Representative's address



Sunrise Medical S.r.l.
Via Riva, 20 – Montale
29122 Piacenza
Italia
Tel.: +39 0523 573111
Fax: +39 0523 570060
www.SunriseMedical.it

Sunrise Medical AG
Erlenauweg 17
CH-3110 Münsingen
Schweiz/Suisse/Svizzera
Fon +41 (0)31 958 3838
Fax +41 (0)31 958 3848
www.SunriseMedical.ch

Sunrise Medical AS
Delitoppen 3
1540 Vestby
Norge
Telefon: +47 66 96 38 00
post@sunrisemedical.no
www.SunriseMedical.no

Sunrise Medical AB
Neongatan 5
431 53 Mölndal
Sweden
Tel.: +46 (0)31 748 37 00
post@sunrisemedical.se
www.SunriseMedical.se

MEDICCO s.r.o.
H – Park, Heršpická 1013/11d,
639 00 Brno
Czech Republic
Tel.: (+420) 547 250 955
Fax: (+420) 547 250 956
www.medicco.cz
info@medicco.cz
Bezplatná linka 800 900 809

Sunrise Medical Aps
Mårkærvej 5-9
2630 Taastrup
Denmark
+45 70 22 43 49
info@sunrisemedical.dk
Sunrisemedical.dk

Sunrise Medical Australia
11 Daniel Street
Wetherill Park NSW 2164
Australia
Ph: +61 2 9678 6600
E: enquiries@sunrisemedical.com.au
www.SunriseMedical.com.au

Sunrise Medical
North American Headquarters
2842 Business Park Avenue
Fresno, CA, 93727, USA
(800) 333-4000
(800) 300-7502
www.SunriseMedical.com



Sunrise Medical GmbH
Kahlbachring 2-4
69254 Malsch/Heidelberg
Deutschland
Tel.: +49 (0) 7253/980-0
Fax: +49 (0) 7253/980-222
www.SunriseMedical.de

Sunrise Medical
Thorns Road
Brierley Hill
West Midlands
DY5 2LD
England
Phone: 0845 605 66 88
Fax: 0845 605 66 89
www.SunriseMedical.co.uk

Sunrise Medical S.L.
Polígono Bakiola, 41
48498 Arrankudiaga – Vizcaya
España
Tel.: +34 (0) 902142434
Fax: +34 (0) 946481575
www.SunriseMedical.es

Sunrise Medical Poland
Sp. z o.o.
ul. Elektronowa 6,
94-103 Łódź
Polska
Telefon: + 48 42 275 83 38
Fax: + 48 42 209 35 23
E-mail: pl@sunrisemedical.de
www.Sunrise-Medical.pl

Sunrise Medical B.V.
Groningenhaven 18-20
3433 PE NIEUWEGEIN
The Netherlands
T: +31 (0)30 – 60 82 100
F: +31 (0)30 – 60 55 880
E: info@sunrisemedical.nl
www.SunriseMedical.nl

Sunrise Medical HCM B.V.
Vossenbeemd 104
5705 CL Helmond
The Netherlands
T: +31 (0)492 593 888
E: customerservice@sunrisemedical.nl
www.SunriseMedical.nl
www.SunriseMedical.eu
(International)

Sunrise Medical SAS
ZAC de la Vrillonnerie
17 Rue Michaël Faraday
37170 Chambray-Lès-Tours
Tel : +33 (0) 2 47 55 44 00
Email: info@sunrisemedical.fr
www.sunrisemedical.fr

